

Seitech Launching Dolly
Configuration 4
Packing List

Part #	Description	Quantity
F01	Machine Screw, 1/4" x 2 1/4"	20
F02	Machine Screw, 1/4" x 1 3/4"	4
F03	Lock Nut, 1/4"	24
F06	Hitch Pin Clip	2
F25	Hex Cap Screw, 1/4" x 2 1/2"	2
F26	Wing Nut, 1/4"	2
ET1	Edge Trim, 5.75"	1
H2A	Handle Grip	2
P02	Handle Bracket	1R, 1L
P04-PC	Heel Bracket	1R, 1L
P05-A-PC	T-Bracket, Closed	1
P06-PC	Axle Bracket	2R, 2L
P07-B	Sling Bracket	2R, 2L
P09	V-Support	1
S1	Sling	1
T1A	Bow Stanchion, Sq. Tube 1 1/2"	1
T1B	Fwd. Centerline Tube Assembly, Sq. Tube 1 1/2"	1
T1C	Aft Centerline Tube, Sq. Tube 1 1/2"	1
T1D	Axle Tube, Sq. Tube 1 1/2"	1
T1E	Side Stanchion, Sq. Tube 1 1/2"	2
T3A	Handle Tube, Rd. Tube 1" x 13 1/2"	1

SEITECH Products Inc. Assembly Instructions

Dolly Configurations 1, 2, 3, 4, and 7

Tool Required: Large Phillips Head Screwdriver

Recommended Tool: Rubber Mallet

Use Packing List for Part Identification

Axle Tube Assembly:

Step 1: Connect the **T1E Side Stanchions**, to the **T1D Axle Tube**, through the **P06 Axle Brackets** without brackets at this time. Make sure the Seitech sticker faces aft.

Step 2: Insert the **T7B Wheel Shafts** into the P06 Axle Brackets until all 4 holes line up. Secure with the **F01, F02, and F03** fasteners. Repeat on the opposite P06 Axle Bracket.

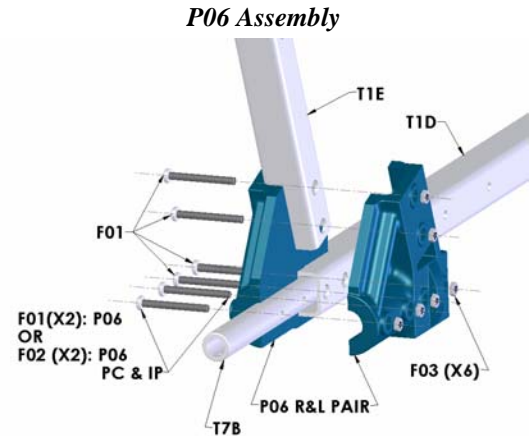

Step 3: Connect the **S1 Sling** to the **T1E Side Stanchions** through the **P07-A Sling Brackets**.

If your dolly has **P08 Stabilizer Brackets**; add each P08 Stabilizer Bracket to each **P07-B Sling Bracket**. Make sure the P08 Stabilizer Bracket is facing outward. VERY IMPORTANT – Flip P08 Stabilizer Brackets up under the gunwhale for boat storage or rigging only. Flip P08 Stabilizer Brackets down for launching and retrieving.

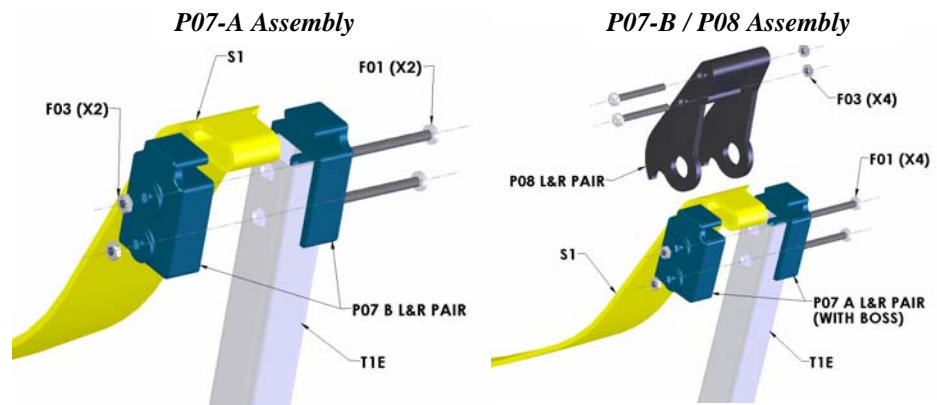

Centerline Tube Assembly:

Step 5: Assemble **T1B Forward Centerline Tube** and **T1C Aft Centerline Tube**, or **T1B Forward Centerline Tube** and **T1M Middle Centerline Tube** and **T1C Aft Centerline Tube**. A **T1BC Centerline Tube** is one tube and it comes complete

Step 6: Install the required supports for your dolly on the forward part of the Centerline Tube. Either Slide on the **P09 V-Supports** to desired location. Tip: the P09 V- Supports slide on easier with warm water or liquid soap Or attach **T1G Cross Tube Support** with F01 and F03 fasteners

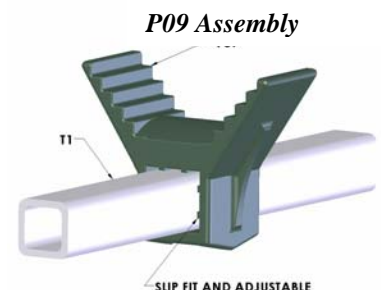

Step 7: Connect the **T1A Bow Stanchion** to the Centerline Tube Via **P04 Heel Bracket** (40 degree angle) or **P13 Heel Bracket** (15 degree angle)

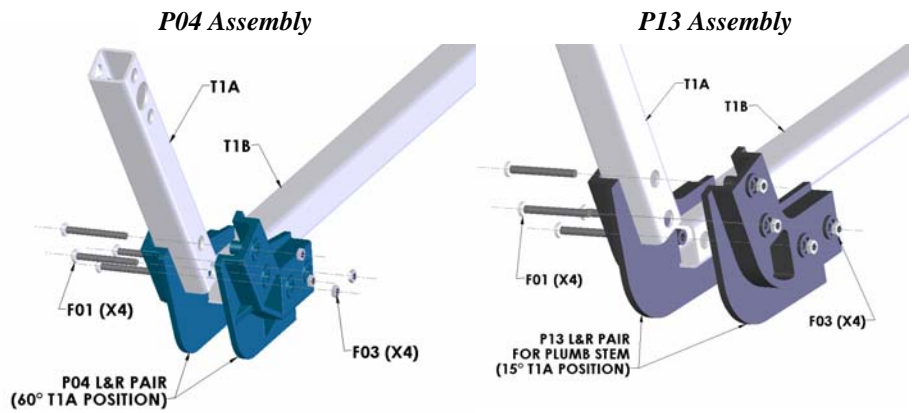

Note: Make sure your **P04 Heel Bracket** or **P14 Heel Bracket** is oriented correctly as indicated in the drawing



Step 8: Slide **P09 V-Support** over the **T1A Bow Stanchion** to your desired location (see tip in step 6)

Step 9: Check your dolly diagram / packing list for the type of Handle Bracket you have, **P01 Handle Bracket**, **P02 Handle Bracket**, or **P03 Handle Bracket**. Slide handle tube through the Handle Bracket until centered. With the palm of your hand, gently tap both **H2A Handle Grips**, onto the handle tube from both ends.

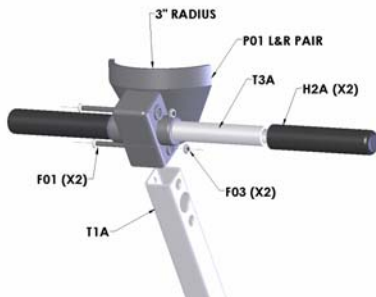
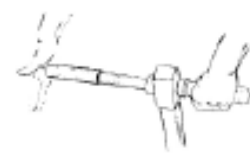

P01 Assembly

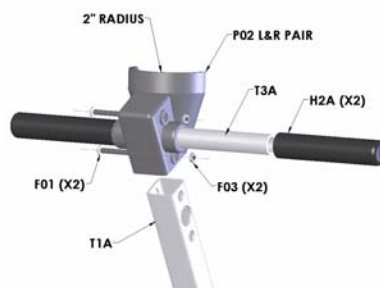

P02 Assembly

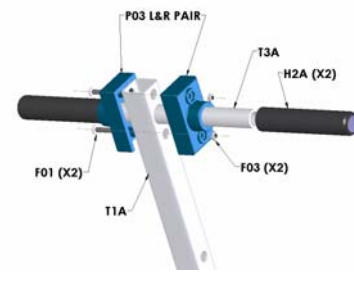

P03 Assembly

Final Assembly:

Step 10: Connect Axle Tube Assembly to Centerline Tube Assembly through the **P05 T-Bracket** using the **F25 and F26 Fasteners**. Follow the diagram for the correct orientation of the P05 T-Bracket before you attach it to the aft end of the Centerline Tube.

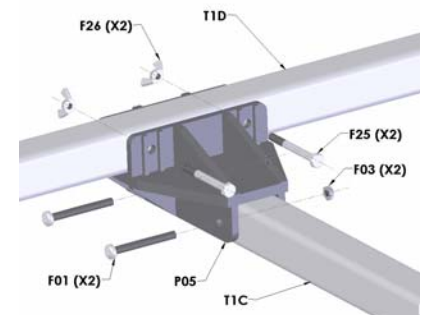

P05 Assembly

Step 11: Slide each **Wheel** over the T7B Wheel Shafts and secure with the **F06 Pin Clip**.

SEITECH Products Inc.
Wheel and Bearing Assembly
Tools Required: Rubber Mallet
Use Packing List For Part Identification



Your Bearing Bag will include two bearings (W-RB 60) and four wheel retainer rings (P14)

Step 1: Place One of the Retainer Rings (P14) in the wheel



Step 2: Use a Rubber Mallet to fasten in the wheel retainer ring (P14)



Step 3: Drop in your wheel bearing (W-RB 60) and repeat steps 1 and 2 to fasten in the wheel bearing (W-RB 60)



SEITECH Wheel Kits Packing Lists

With your SEITECH Dolly you received one of the following wheel kits. These are the following packing lists for each wheel kit.

Part #	Description	Component #	Description	QTY
W7C-KIT	Wheel, Kit, Standard	W7C	A Wheel	2
W7C-KIT	Wheel, Kit, Standard	W-RB 60	Roller Bearing	2
W7C-KIT	Wheel, Kit, Standard	P14	Retainer Ring	4
W7C-KIT	Wheel, Kit, Standard	T7B-9 5/16	Wheel Shafts	2

Part #	Description	Component #	Description	QTY
W7C-P15-KIT	Wheel, Kit, Std Wheels, P15	W7C	A Wheel	2
W7C-P15-KIT	Wheel, Kit, Std Wheels, P15	W-RB 60	Roller Bearing	2
W7C-P15-KIT	Wheel, Kit, Std Wheels, P15	P14	Retainer Ring	4
W7C-P15-KIT	Wheel, Kit, Std Wheels, P15	T7B-6 3/4	Wheel Shafts	2

Part #	Description	Component #	Description	QTY
W4C-KIT	Wheel, Kit, F Wheels, Standard	W4C	F Wheel	2
W4C-KIT	Wheel, Kit, F Wheels, Standard	W-RB 60	Roller Bearing	4
W4C-KIT	Wheel, Kit, F Wheels, Standard	P14	Retainer Ring	4
W4C-KIT	Wheel, Kit, F Wheels, Standard	T7B-11 3/4	Wheel Shafts	2

Part #	Description	Component #	Description	QTY
W4C-P15-KIT	Wheel, Kit, F Wheels, P15	W4C	F Wheel	2
W4C-P15-KIT	Wheel, Kit, F Wheels, P15	W-RB 60	Roller Bearing	4
W4C-P15-KIT	Wheel, Kit, F Wheels, P15	P14	Retainer Ring	4
W4C-P15-KIT	Wheel, Kit, F Wheels, P15	T7B-9 1/4	Wheel Shafts	2

Part #	Description	Component #	Description	QTY
W4C-CAT-KIT	Wheel, Kit, F Wheels, CAT	W4C	F Wheel	2
W4C-CAT-KIT	Wheel, Kit, F Wheels, CAT	W-RB 60	Roller Bearing	4
W4C-CAT-KIT	Wheel, Kit, F Wheels, CAT	P14	Retainer Ring	4
W4C-CAT-KIT	Wheel, Kit, F Wheels, CAT	T7B-15 3/4	Wheel Shafts	2
W4C-CAT-KIT	Wheel, Kit, F Wheels, CAT	W-S-1 1/2	Spacer, Wheel, Catamaran	2
W4C-CAT-KIT	Wheel, Kit, F Wheels, CAT	W-S-4 1/8	Spacer, Wheel, Catamaran	2

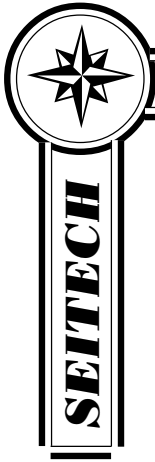

ONE YEAR WARRANTY

Manufacturer's Limited Warranty

Every care has been taken in the manufacture of your SEITECH dolly and it is warranted for one year against defects in workmanship and material when properly used, cared for, and maintained. We will replace, free of charge, any part which proves upon examination to be defective under normal use.

For your records:

Purchase Date: _____

Purchased From: _____

SEITECH Products, www.Seitech.com, 401.683.6898



Please return to:

SEITECH Products

300 Highpoint Ave., Portsmouth, RI 02871

ONE YEAR WARRANTY

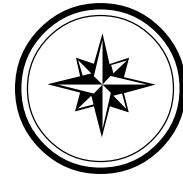

Name _____

Street Address _____

City _____ State _____ Zip Code _____

e-mail _____

Would you like to be placed on our mailing list ___ Yes ___ No

Purchase Date: _____ Purchased From: _____

Type of Boat: _____

If this is for a sail boat please continue:

Do you use your boat for: ___ Recreation ___ Racing, club level ___ Racing, Nationally

How many years have you been sailing? _____

Where did you learn to sail? ___ Parents ___ Yacht Club ___ Sailing school ___ Community program

___ Self taught ___ Friend ___ Camp ___ Other

Comments: _____
