

Owner's Manual

Volume 1

GENERAL INFORMATION-PRECAUTIONS-SAFETY

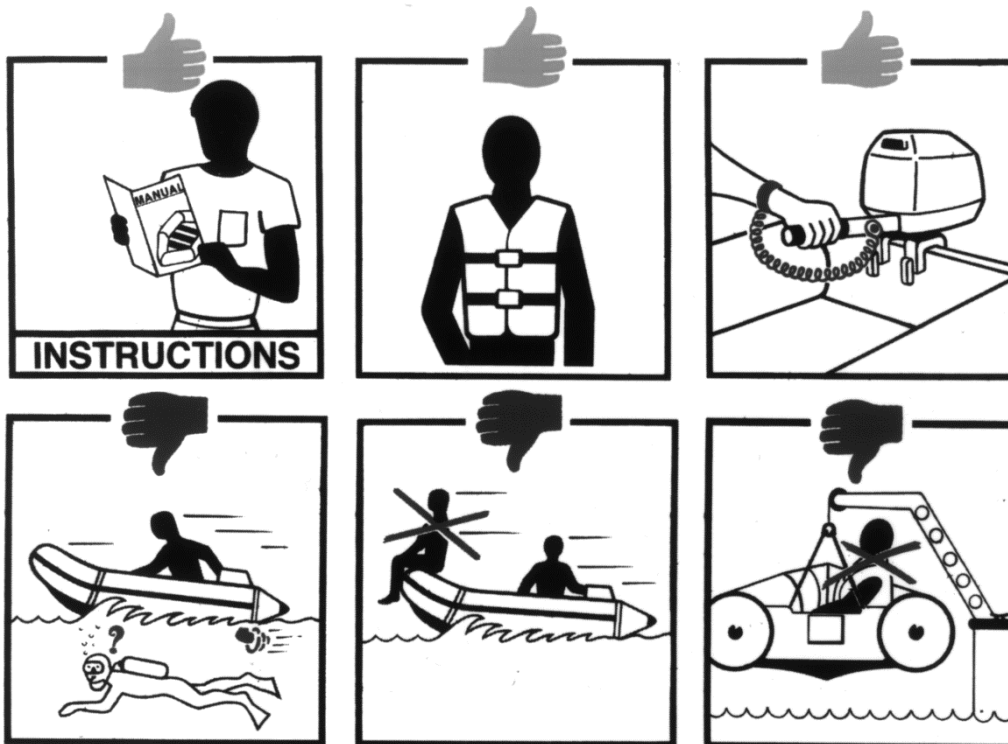

WARNING

- CAREFULLY READ THIS MANUAL BEFORE PUTTING YOUR BOAT INTO SERVICE
- THE OWNER'S MANUAL IS DIVIDED INTO TWO VOLUMES

611957 - A

<p>NOTE:</p>	<p>The owner's manual is divided into two volumes:</p> <p>Volume 1</p> <p>Deals with operating precautions and safety recommendations that must be observed.</p> <p>Volume 2</p> <p>Deals with technical specifications and assembly procedure of the boat and its equipment.</p>
---------------------	--

	<p>Boats are fun, and we want you to enjoy it for years to come.</p> <p>Please spend some time reading your Owner's Manual and Safety Precautions to understand the operation and safety considerations of this boat.</p> <p>And don't forget: Safety First!</p>
---	---

VOLUME 1

GENERALITIES - PRECAUTIONS - SECURITY

CONTENTS

	Page		Page
⇒ Recommendation signs	2	⇒ Handling	
		1. mooring and towing	15
⇒ An important Message - Validity	3	2. lifting / davits	15
		3. hauling on trailer	16
⇒ Certification - Identification	4		
		⇒ Maintenance	
⇒ Manufacturer's ID plate	4-6	1. cleaning	17-18
		2. wintering - storage	18
⇒ Type of motor and adjustment		3. regular verifications	18
1. type of motor	7	4. how to repair small punctures	19
2. type of propeller	7	5. rigid inflatable boats: small repairs	19
3. installing the motor	8		
4. adjustment	8-9	⇒ Troubleshooting guide	20
⇒ Operating instructions	10-13	⇒ Warranty - General conditions	21
⇒ Environment	14	⇒ At your service	22

RECOMMENDATIONS SIGNS

This manual contains essential information for the protection of users and equipment.
The symbols below are advisories relative to various types of situations.

SECURITY RECOMMENDATIONS

 <p>DANGER</p>	<p>Means that there is an extremely serious danger that could result in a very likely probability of death or fatal injury if specific steps are not taken.</p>
--	---

 <p>WARNING</p>	<p>Means that there is a danger that could result in injury or death if specific steps are not taken.</p>
---	---

 <p>WARNING</p>	<p>Provides a reminder of safety measures or draws attention to dangerous practices that could cause injuries or damage the boat or its components.</p>
---	---

GENERAL RECOMMENDATIONS

	<p>This procedure or behaviour complies with the instructions.</p>
---	--

	<p>This procedure or behaviour does not comply with the instructions thus risking damage equipment.</p>
---	---

<p>NOTE:</p>	<p>Draws attention to important indications.</p>
---------------------	--

AN IMPORTANT MESSAGE

Congratulations on your purchase of an inflatable boat. We take pride in bringing you a quality product which will offer you years of pleasure. Your boat is an investment which deserves your care and attention.

It was drawn up to help you get pleasure out of using your boat in complete comfort and safety. It contains, in Volume 2, the description of the boat, the equipment supplied or installed, and methods and indications needed for its use and servicing. Read it carefully, and familiarize yourself with the craft before using it.

Serious personal injury and death can occur in and around boats. To prevent these tragic accidents, please read, understand and strictly enforce all safety rules. If this is your first boat, or if you are not familiar with our products, please make sure you practice and get used to it before you assume its command. Your salesperson, your dealer, your national nautical Federation or your club will be very happy to advise you on boating schools and competent instructors.

 WARNING	<ul style="list-style-type: none"> • We advise you to keep the owner's manual on board your boat, in a safe, readily accessible place to allow it to be consulted by the driver. • IT IS ALSO RECOMMENDED TO KEEP WITH YOUR MANUAL ANY INSTRUCTIONS ISSUED BY THE MANUFACTURERS OF THE BOAT'S EQUIPMENT (ACCESSORIES, ETC.). • THIS MANUAL IS PART OF THE BOAT'S EQUIPMENT AND MUST ACCOMPANY IT IF TRANSFERRED OR SOLD.
--	--

VALIDITY AND COMPOSITION

Our commitment to constantly keep pace with the latest advances in technology requires that we reserve the right to change the characteristics or the availability of a boat model for the benefit of our customers.

The information in this manual concerns this boat at the time of issue. This is in no case contractual.

NOTE:	We take no responsibility for the consequences of actions not complying with the instructions given in this manual.
--------------	--

APPROVAL / CERTIFICATION / IDENTIFICATION

Our boats comply with ISO standard 6185, established by the International Standards Organization, and with European Directive 2013/53/EU.

We are also a member of the American Nautical Manufacturers Association (NMMA), the French Nautical Industries Federation (FIN) and the Association for Eco-Responsible Yachting (APER Plaisance) which allows owners have their boat (registered in France) dismantled free of charge at the end of its service life.

Record below the data indicated on the manufacturer's plate provided on the inside of the transom. You may need them to help identify your boat for insurance purposes in case of theft or for after-sales service.

Carefully record the model (1) and the serial number (2) of your boat, and the ID number provided on the plate outside the transom, near the outboard (XDC) (11).

① Manufacturer's ID plate

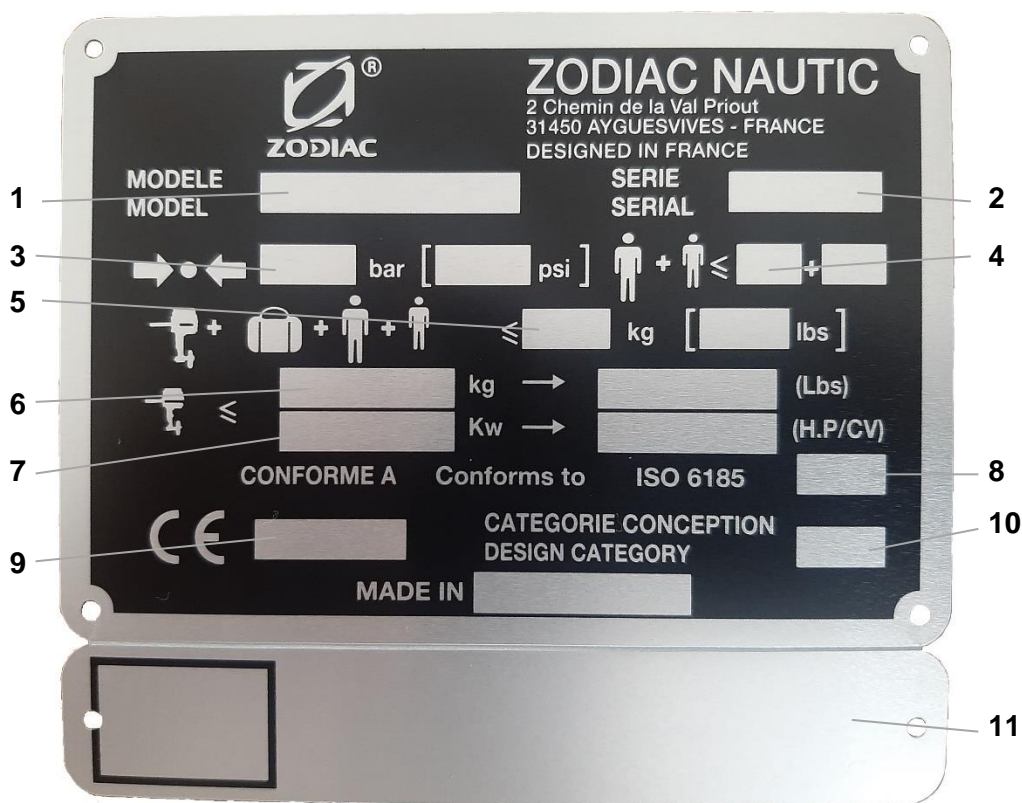

MANUFACTURER'S ID PLATE

The indications on the manufacturer's plate on the transom are important:

They give information about limitations imposed by local or national regulations.

However, these indications **are not a complete list**: the safety requirements (the boat's mandatory safety equipment, maximum authorized distance you can navigate from a shelter, etc.) may change according to the country or state **Always refer to local regulations to be informed on additional requirements.**

(1) **Model:** Commercial name of the model.

(2) **Serial number:** boat's serial identification number. To be provided for any after-sales service operation, and for the purchase of spare parts or accessories.

(3) **Nominal inflation pressure** of buoyancy tubes in bar and PSI. Other parts of the boat may have different inflation pressures. Refer to the INFLATION chapter (VOLUME 2 of the Owner's Manual) or to the indications on the valves.

(4) **Maximum number of passengers** allowed on board the boat in the case of adapted equipment (adults + possibly 1 child) as per ISO standards

(5) **Maximum load capacity** of the boat allowed by the constructor expressed in kilograms and in pounds (people + engine and its fuel tank filled to the top + diverse loads, etc.), defined as per the current version of standard ISO 14945

(6) **Maximum engine weight** allowed by the constructor for the boat expressed in kilograms and in pounds (lbs)

(7) **Maximum engine power** allowed by the constructor for the boat expressed in kilowatts and in Horse Power (HP)

(8) **ISO Category:**

Your boat complies with ISO 6185 Standard. The engine rating defines its category.

ISO CATEGORY	II	V	VII
Motor rating in kW	0 - 4.5 kW	4.5 - 15 kW	>15 kW
Motor rating in HP	0 - 6 CV/HP	6 - 20 CV/HP	>20 HP

(9) **CE:** Sign of the certification to the European Directive 2013/53/ EU (for overall length > 2.5 m), followed by the certification organism number and the year of CE certification – for B design category only).

(10) **Design category (European directive 2013/53.EU)** (for overall length > 2.5 m):

In Europe, your boat has been designed to navigate under different categories:

Category	B	C	D
Navigation	"offshore"	"inshore"	"sheltered waters"
Wind speed (Beaufort scale)	Up to and including 8	Up to and including 6	Up to and including 4
Wave significant height (m)*	Up to and including 4	Up to and including 2	Up to and including 0.5

*It represents the average height of the upper third of the waves, which approximately corresponds to the wave height estimated by an experienced observer.. *Some waves will have a height double this value.*

Some of our boats are approved for two navigation categories. In order to fully indicate the characteristics relating to each category, they have two separate manufacturer's plates.

(11) **Small plate** with the Craft Identification Number (generally fixed on the external side of the transom) needed for any after-sale service operation.

 WARNING	<p>Be responsible, take notice of these parameters when you plan your navigation program, and do not put to sea if the conditions are likely to exceed these parameters.</p>
---	--

TYPE OF MOTOR AND ADJUSTMENT

1. TYPE OF MOTOR

1.1 Motor's power

- The maximum and recommended powers are listed in the table of technical specifications (see VOLUME 2 of the Owner's Manual).
- For smaller outboards, go for tiller control, giving direct control over the boat and allowing for quick manoeuvring.

Above 25 CV/HP, for greater comfort and safety, we recommend that you choose a steering console.

 WARNING	<p>Never use motor power higher than indicated on the manufacturer's id plate: It could also result in loss of control, and you would be breaking the law.</p>
---	---

NOTE:	<p>The maximum authorized power, when greater than the maximum recommended power, must be used with extreme caution. It is directed at experienced users using their boats for very specific purposes (carrying heavy loads, etc.).</p> <p>It is recommended that you choose your outboards' power in accordance with your principal boating activities. Refer to the recommended power (see VOLUME 2).</p> <p>Over-powered your boat can be difficult to control. Under-powered and you may not have that margin of security necessary to go upwind or against the currents.</p>
--------------	--

1.2 Motor weight

The motor's weight has a great influence on the planning, stability and performances of the inflatable boat. For equal power, we recommend that you choose a light motor.

You must never exceed the maximum authorized motor weight indicated on the manufacturer's plate.

1.3 Motor shaft Length

Four different shaft lengths are available: **S/L/XL/XXL**. Each boat is designed for a specific shaft, **interchanging is not possible**. Check which length is required for your boat, and use the proper size (refer to Owner's Manual volume 2).

2. TYPE OF PROPELLER

- In order to choose the optimal propeller for your principal use, your boat and its motor must be tested at sea. Ask your Dealer to assist you.
- In general, the propeller provided with the motor is adapted to all types of navigation. Nevertheless, according to the principal use you intend to make of the boat, go for:

A **lower pitch** when the boat is heavily loaded or used for water skiing.

A **higher pitch** will increase the speed potential (if the boat is lightly loaded).

 DANGER	All contact with a rotating propeller can result in serious injury or even death. KEEP AWAY FROM THE PROPELLER.
--	--

INSTALLING AND ADJUSTING THE MOTOR

3. INSTALLING THE MOTOR

- Install the motor along the centreline of the boat, in the middle on the mounting plate (4)
- Fully tighten the tightening plate (1) by hand and check that they are still properly tightened after 15 minutes of running.
- For all questions regarding engine bolting, please contact your nearest dealer.
- Secure the motor to the loop (3) on the motor tightening plate (1) with a safety cable (2).
- All engines above 4 HP are equipped with a safety stop lanyard (5), which is an essential safety element: always attach it to your wrist (refer to the chapter entitled "Operating instructions").

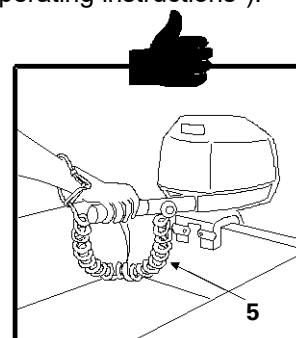
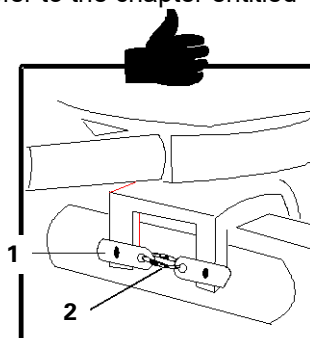
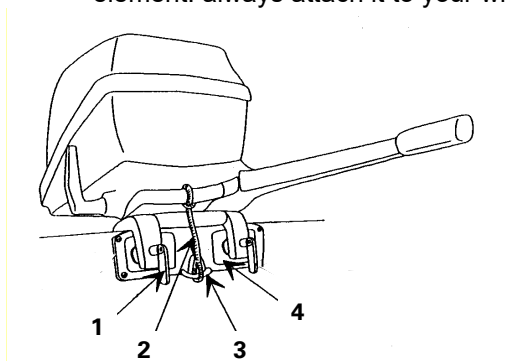

WARNING

- The bolting of the motor to the transom is suggested from 10 HP and highly recommended from 25 HP and above.
- FOR ALL OUTBOARDS FROM 25 HP AND ABOVE WE RECOMMEND THE INSTALLATION OF A REMOTE STEERING UNIT.



WARNING

- For engines that are not bolted to the transom: regularly check that the tightening plates stay properly tightened.
- For remote controls: regularly check their operation.

NOTE:

Bolting is to be done once the motor is evenly positioned. Have the motor bolted to the transom by your dealer.

4. ADJUSTMENTS

The motor requires a double position adjustment in tilt and height that greatly and directly impacts on the boat's attitude.

You will have to adjust the motor in height only once. On the contrary, to optimize performances and good manoeuvrability, you will have to adjust the angle of the motor in relation to the transom depending on the navigation conditions (adjustment bar or electric trim).

4.1. Motor height

The motor is mounted on the transom... Depending on the brand of engine, using the same shaft type the size may vary by a few centimetres. A shim is sometimes required to ensure that the engine is positioned properly.

Motor adjusted too high = ventilation may occur with loss of forward thrust (cavitation)

Motor adjusted too low = loss of speed and more difficult steering may occur (splashes).

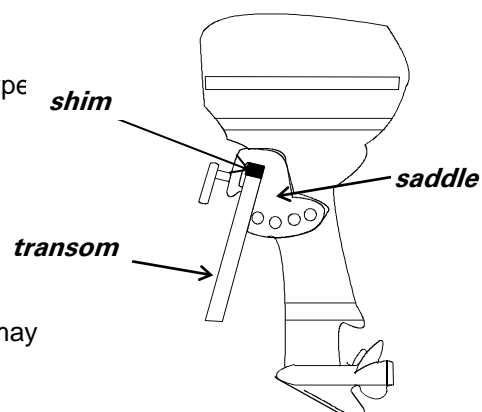

ADJUSTING THE MOTOR



4.2 Motor position (TRIM)

As a rule, the motor must be positioned so that the axis of the propeller is parallel with the water surface.

However, an adjustment of the tilt is often recommended (see the chapter Operating instructions of this manual).

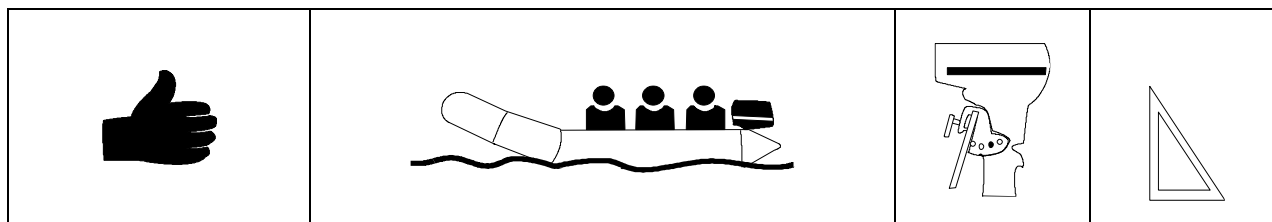
The adjustment of the tilt can be manual or assisted by an electric Trim (when equipped).

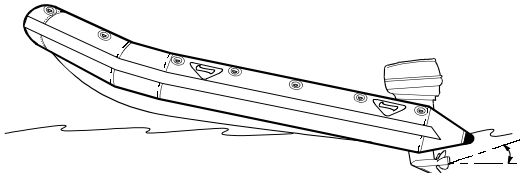
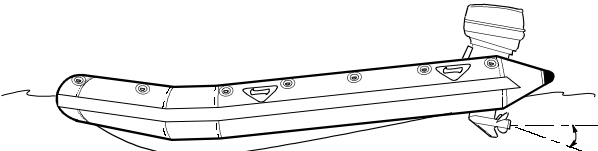

 	<p>Motor tilted outwards too far from the transom. the boat will porpoise.</p>  <p>Motor tilted inwards too near the transom: the boat will nose down.</p> 
--	---

 <p>WARNING</p>	<p>If your engine has manual tilt adjustment, stop the engine before making any modifications.</p>
--	---

<p>NOTE:</p>	<p>For specific information concerning the motor itself, refer to the motor's manual.</p>
---------------------	---

OPERATING INSTRUCTIONS**Distribution of the load:**

- Evenly distribute the load. (For example, fixing the fuel tank on the front can help to offset the weight of the outboard).
- When using a hand tiller, we recommend that the driver remains on the starboard side.

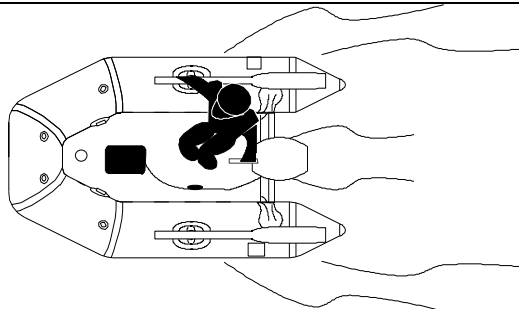
An example of good load distribution:**WARNING**

A bad distribution of the load can destabilize the boat and may result in a loss of control.

**WARNING**

The boat reacts more roughly when lightly loaded. Be particularly careful when you accelerate or change direction.

Depending on the navigation conditions and the waves direction, it may be necessary to adjust the load distribution and the trim.

In a "head on" sea

- load the bow, and if necessary, adjust the engine's inclination
- the tilt pin should be in the 1st or 2nd hole position

Negative TRIM

In a "following" sea

- load the stern, and if necessary, adjust the engine's inclination
- the tilt pin should be in the 3rd or the 4th hole position

Positive TRIM

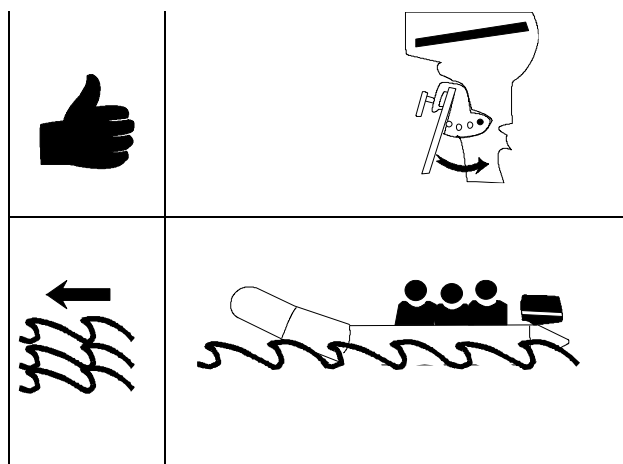
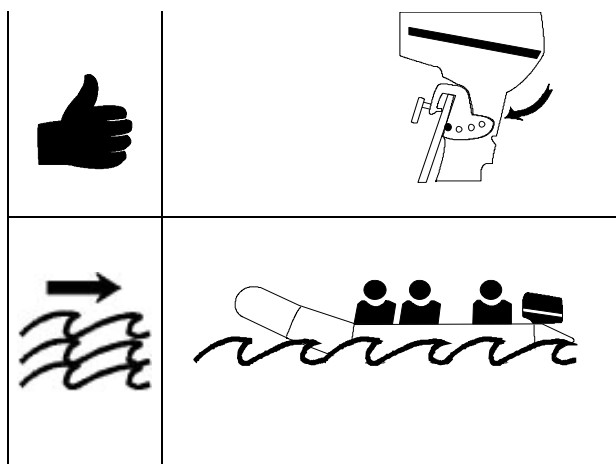

 WARNING	<p>Do not operate the boat at high speed with a negative trim setting (low bow). This can cause the boat to list and may result in instability in turns. Use a negative trim setting to shift from travelling speed to hydroplaning speed, and at lower speeds in chop (if your engine is equipped with an electric trim).</p>
---	--

OPERATING INSTRUCTIONS

SAFETY FIRST: Learn how to avoid accidents

CHECK-LIST BEFORE DEPARTING

 WARNING	<p style="text-align: center;">Get required information and inform other passengers:</p> <ul style="list-style-type: none"> <input checked="" type="checkbox"/> GET INFORMED ON LOCAL REGULATIONS AND HAZARDS RELATED TO WATER ACTIVITIES AND BOAT OPERATION. <input checked="" type="checkbox"/> CHECK weather forecast, local currents, tides and wind conditions. <input checked="" type="checkbox"/> ADVISE someone on land of the time you plan to be back. <input checked="" type="checkbox"/> LEARN HOW TO DETERMINE THE DISTANCE YOU CAN COVER WITH A FULL FUEL TANK, AND REMEMBER THAT BAD WEATHER CONDITIONS CAN ALTER THIS. Always be sure you have enough fuel to reach a shelter. <input checked="" type="checkbox"/> EXPLAIN basic boat operation to all passengers. <input checked="" type="checkbox"/> BE SURE that one of your passengers can operate the boat in case of emergency.
	<p style="text-align: center;">Check that all equipment is in good operating condition in keeping with the sea conditions and the intended use</p> <ul style="list-style-type: none"> <input checked="" type="checkbox"/> CHECK the pressure of the buoyancy tube. <input checked="" type="checkbox"/> CHECK the thru-hull openings: remove the self-bailer plugs and check that the drain holes are closed on the outside of the boat. <input checked="" type="checkbox"/> CHECK that the stop switch is in proper working order. <input checked="" type="checkbox"/> CHECK that the engine is securely bolted to the transom. <input checked="" type="checkbox"/> CHECK and clean your fuel filter, if so equipped. <input checked="" type="checkbox"/> CHECK how much fuel you have. <input checked="" type="checkbox"/> DO NOT FORGET to fill up the oil level if your motor has a separate oil tank. <input checked="" type="checkbox"/> CHECK the security of your fuel tank. Check that all mobile elements are secured. <input checked="" type="checkbox"/> BE SURE motor is not in gear before starting.

	<p style="text-align: center;">EQUIPMENT ON BOARD: (Check the laws and regulations of the country or locality in which you are boating).</p> <ul style="list-style-type: none"><input checked="" type="checkbox"/> One personal flotation device (PFD) per person, adapted to the person's morphology and area of operation.<input checked="" type="checkbox"/> The foot-pump, paddles (or the oars), repair kit and tool kit.<input checked="" type="checkbox"/> The mandatory safety equipment.<input checked="" type="checkbox"/> The boat papers and your boating license.<input checked="" type="checkbox"/> Lights are required if operating after dark.
--	---

OPERATING INSTRUCTIONS**SAFETY FIRST: LEARN HOW TO AVOID ACCIDENTS****RULES TO OBSERVE DURING NAVIGATION**

- Be responsible: do not neglect the safety rules, this could jeopardize your life and the lives of others.
- Observe the rules of priority as defined by the steering and sailing rules established by the International Regulations for Preventing Collisions at Sea (COLREG - *Collision Regulations*)
- Ensure that you always have sufficient distance to stop or manoeuvre to avoid a collision, if necessary.
- Do not navigate at maximum speed in areas of heavy traffic, low visibility, strong winds or high waves.
- Reduce the boat's speed and wake as a courtesy and safety measure for yourself and others. Observe the speed and wake limit zones.
- Learn to always keep control of your boat.
- Always operate with courtesy and respect.
- Respect local regulations and practices.
- Near the shore, navigate in the designated boating areas and at low speed.
- At sea, weather conditions can rapidly deteriorate. Always be sure that you can reach a shelter rapidly.



BEWARE OF OFFSHORE WINDS AND CURRENTS!

**WARNING**

LIFE JACKETS: we recommend that life jackets be worn while underway and, without exception, by children and non-swimmers.

STOP SWITCH LANYARD: always attach the stop switch lanyard, preferably to your wrist, or failing that, on a fixed element of the garment you are wearing. Your outboard comes equipped with a stop switch safety lanyard to prevent a runaway boat in case the operator falls overboard.

NO ALCOHOL OR DRUGS: do not drink alcohol or take drugs before or while operating your boat. Maintain passenger sobriety.

Do not exceed the authorized number of passengers, power or weight.

MAKE SURE YOUR PASSENGERS are never seated at the front, with the legs **OUTSIDE THE BOAT:** Should they fall, the man overboard is in the path of the propeller.

ENSURE that passengers are in a safe position, avoid abrupt changes in course unless absolutely necessary.

Reduce the speed in waves for the comfort and safety of passengers.

In any case, warn the passengers before the manoeuvre.

AVOID SHARP TURNS AT HIGH SPEED: You would risk ejecting your passengers and yourself.

BE PARTICULARLY VIGILANT WHEN DOCKING: Arms or legs can be injured if they are outside the boat when manoeuvring.

KEEP CLEAR OF SWIMMERS AND DIVERS:

Always avoid areas where divers/swimmers are in the water. Keep a sharp lookout especially when operating near beaches and launch sites. Shut off the motor when operating near someone in the water.

The Alpha flag indicates the presence of divers in the area: it is imperative to stay clear of the area (at least 100 metres).

Never disembark without first having moored or anchored your boat.

OPERATING INSTRUCTIONS

SAFETY FIRST: Learn how to avoid accidents

RULES TO OBSERVE DURING NAVIGATION (cont'd)**WARNING**

- BEWARE:** Avoid all contact between the buoyancy tube and sharp objects or aggressive liquids (such as acid).
- BATTERY:** Avoid sparks and open flames near battery (hydrogen gas from battery may explode).
- AVOID THE RISKS OF EXPLOSION OR FIRE HAZARDS:** Ensure your fuel system is in a good order and maintain it properly.
- AVOID SMOKING ON BOARD** and most particularly while filling the fuel tank.
- If fuel spills on the bottom of the boat, rinse with plenty of water.**

IN CASE OF ACCIDENT

In case of accident, do not panic, and reassure passengers. Be aware that the boat, even damaged, is often the best shelter and facilitates your rescue. Do not attempt to swim back to shore.

An inflatable boat is practically unsinkable, even when filled with water. If, after an accident, a compartment deflates, bring it back towards the inside of the boat, rebalance the load away from the deflated compartment and head back at reduced speed.

In the event of collision or impact with a floating object, stop to examine the bottom (the hull for RIBs), the floats, the engine and its mounting attachments before heading back at reduced speed.

Before your next outing, take your boat to your dealer for a rigorous inspection.





Neglecting inspections and repairs may lead to a serious injury and will reduce the life of your boat.

ENVIRONMENT

Responsible boating begins with you

With your inflatable boat, you can discover the richness of the marine environment. Help keep it beautiful. Enjoying some time on the water is great, but it comes with some responsibility for us all to work to ensure that the world around us remains a strong healthy environment for living and play. Please, respect your environment by applying the following basic safety rules:

	<ul style="list-style-type: none"> <input checked="" type="checkbox"/> Respect the life of marine animals. <input checked="" type="checkbox"/> Familiarize yourself with the international regulations governing pollution in the marine environment (MARPOL) and respect them as much as possible. <input checked="" type="checkbox"/> Keep up to date with local environmental regulations and follow the codes of practice. <input checked="" type="checkbox"/> If your boat is equipped with a toilet, do not discharge them or the contents of holding tanks near the coast or in prohibited areas. Instead, use the pumping system available in ports and marinas for this purpose. <input checked="" type="checkbox"/> Use non-polluting antifouling paint and non-polluting cleaning agents. <input checked="" type="checkbox"/> Keep out of designated swimming areas. <input checked="" type="checkbox"/> DON'T MAKE UNNECESSARY NOISE. Excessive noise and untimely exhaust emissions should be avoided. <input checked="" type="checkbox"/> Be careful not to overfill the fuel tank. Excess fuel collected in the holding tank must be carefully collected and disposed of in a suitable bin to prevent accidental discharge into the sea.
---	--

	<ul style="list-style-type: none"> <input checked="" type="checkbox"/> Do not discharge hydrocarbons (oil or fuels) into the environment. <input checked="" type="checkbox"/> Do not litter. Dispose of your garbage and trash properly. If there is no appropriate refuse disposal, bring back your trash. <input checked="" type="checkbox"/> Do not make excessive wake. Remember that the wake your boat trails behind can be destructive to the shore, as well as to other boaters. A boat wake crashing on the shore can cause and accelerate erosion and damage the environment.
---	--

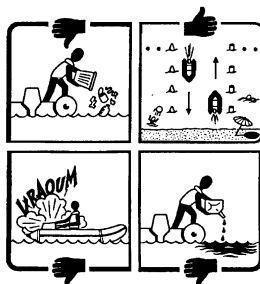

HANDLING

1. MOORING AND TOWING

1.1. MOORING

Fully inflatable boats: Use the buoyancy tube's lateral D-rings.

Rigid inflatable boats: Use the hull's mooring ring.

NOTE:	When moored, the self bailers should remain open to drain the rain water.
--------------	---



1.2. Towing

Fully inflatable boats should always be towed using a bridle; use the 2 lateral D-rings (fixed on the buoyancy tube) made for this purpose. For rigid inflatable boats (RIB), use a single line attached to the mooring ring.

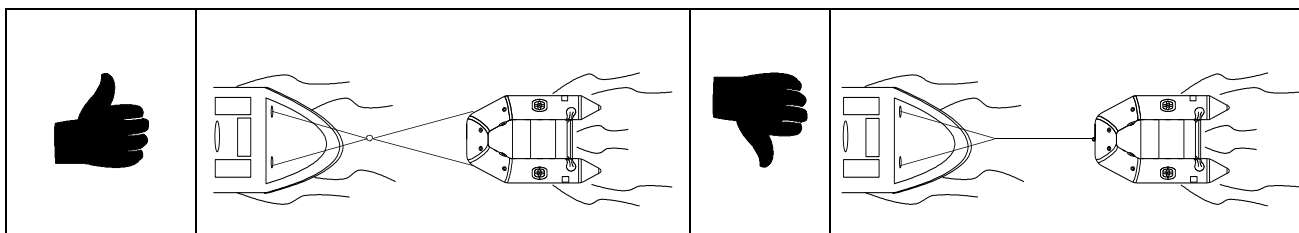

Towing fully inflatable boats:

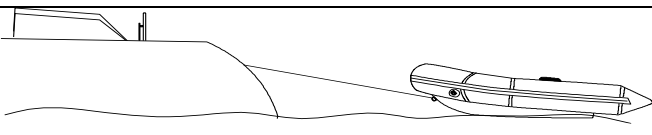

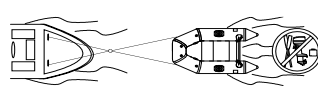
Towing rigid inflatable boats:

Use the towing rings		
Unload the boat before towing (bags, fuel tank, outboard).		

NOTE:	Towing must be done at low speed and in good weather conditions.
--------------	--

 WARNING	<p>Anchor points showing visible signs of deterioration must be replaced. They must therefore be inspected regularly.</p>
 WARNING	<p>A towing cable must always be moored in such a way that it can be released under load.</p>
NOTE:	<p>Ensure that the mooring ropes, towing cables, chains, anchor lines and anchors are adequate for the boat's intended use, in particular that the lines or chains do not exceed 80% of the breaking strength of the corresponding anchor point (see Volume 2). If necessary, ask your Dealer to assist you.</p>

1.3 Mooring to a pontoon

The boat can be moored to a pontoon with at least two mooring lines: one fixed on the bow and one on the stern.

The mooring rope can be fastened on a fixed and strong point on the boat:

RIBS: Cleat, towing ring, mooring bitt, U-bolts (Do not use points not intended for this purpose: Bolt rope, handle, guard rail, handrail, D-rings, etc.)

- Foldable boats and tenders: Cleat, U-bolts, suspension brackets, bow handles (Do not use points not intended for this purpose: Boat rope, handle, small D-ring, etc.).



The boat must be protected from rubbing against the pontoon by fenders.

Mooring lines should not rub against the tube. Should the configuration not allow to avoid this, the buoyancy tube must be protected in areas of friction (Thick fabric or hose around the mooring rope, for example).

Any boat moored to a pontoon should be regularly watched and the mooring lines may need to be strengthened according to the weather conditions.

2. LIFTING - DAVITS

To hoist your boat and place it on davits, use the davit lifting rings provided for this purpose (see Volume 2) or have them installed by your dealer.

 WARNING	No passengers on board while hoisting
 CAUTION	<p>All equipment must be unloaded from the boat for lifting or davit handling.</p> <p>Self bailers should remain OPEN to drain the rain water.</p>

HANDLING

3. HAULING ON TRAILER

- The boat must be properly inflated.
- The self bailer should remain open.

3.1 Fully inflatable boats :

- Adjust the rollers (or supports) (1) of the trailer to fit the shape of the boat.
- Haul the boat onto the trailer using the lateral D rings.
- The bottom of the transom must rest on the trailer bunks.
- Place the motor in the down or trailing lock position so that it can rest on the support provided on the trailer (2).
- Check that the boat lies flat and is properly secured.
- Remove/secure all loose equipment.
- Tie down the straps and ensure the buoyancy tubes are protected against chafing (4).

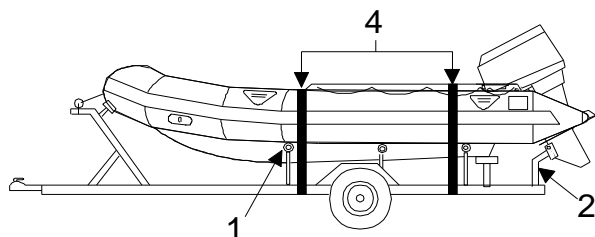

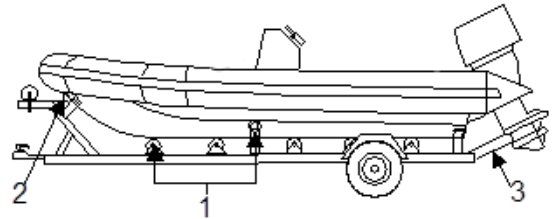

3.2 Rigid inflatable boats:

- Adjust the rollers in the central part so that the entire weight of the boat is resting on these rollers.
- Adjust the rollers or side blocks so as to stabilise the boat (be careful outside the strakes or steps).
- Check if the boat is stable.
- Place the motor in the down or trailing lock position so that it can rest on the support provided on the trailer (3).
- Use the towing rings and the bow ring (if so equipped) to secure the hull securely to the trailer.



- Every thing must be removed or secured to avoid flying away.
- Following the traffic rules you have to protect the propeller with a cover.

 CAUTION	<ul style="list-style-type: none"> • A BAD POSITION OF THE BOAT ON THE TRAILER MAY RESULT IN DAMAGE TO YOUR BOAT AND EQUIPMENT. • Never exceed the trailers' authorised weight capacity.
---	--

 WARNING	<p>ON THE ROAD:</p> <ul style="list-style-type: none"> • Boat must be empty of loose equipment when transported on trailer. • Nobody on board during transportation on trailer.
---	--

MAINTENANCE

The buoyancy tube of your boat is made of fabric using plastomer. Maintenance is easy but essential for the longevity of your boat.

1. CLEANING

Clean your boat frequently, and imperatively before and after wintering.

It is essential to clean your boat regularly, especially the buoyancy tube. You can also entrust this task to your dealer, who has the products and experience necessary to perform a meticulous cleaning that will prolong the life of your boat.



**NEVER USE HIGH PRESSURE CLEANING EQUIPMENT
ON FABRIC ELEMENTS**

1.1 Cleaning the buoyancy tube

Buoyancy tube inflated:

- Open the self bailer and rinse the boat with a hose to remove sand and other debris.
- Regularly clean the buoyancy tube **with fresh water and soap**, at least monthly during periods of use.
- Remove all traces of tar (use the ACCESS product from your Dealer if required).
- Check the tube and high pressure air floor for leaks, with foamy soap and water.
- Rinse with fresh water and dry thoroughly.



No strong detergents (acid, trichlorethylene...), silicone-based products or like agents to be placed on tubes. If a spill occurs, wash off with water.

When deflating:

- Check that the valves and gaskets are clean and not damaged (sealing compound, sand, etc.).
- Check the self bailer is not clogged.

1.2 Check airtightness of your boat:

Note:	<p>Using the pressure indicator (supplied with some models or available from your dealer), measure the pressure loss after 24 hours.</p> <p>LOSS OF PRESSURE</p> <ul style="list-style-type: none"> • Loss of pressure (20%) over 24 hours is not unusual. <p>(ISO 6185 standard permits a certain amount of pressure loss). If loss of pressure exceeds:</p> <p style="padding-left: 40px;">0.145 PSI (0.010 Bar) / 5 hours for buoyancy tube</p> <p style="padding-left: 40px;">0.5 PSI (0.035 Bar) / 5 hours for high-pressure air-floor</p> <p>Check airtightness of your boat.</p> <ul style="list-style-type: none"> • Temperature has a great influence on air pressure. A variation of 1°C results in a variation in the same way of about +/- 4 mb (0.06 PSI). <p>If you have a problem with an air leakage: first, check all valves are intact and in closed position (nothing clogging valve). Do not hesitate to contact your Dealer.</p>
--------------	--

1.3 For rigid inflatable boats: cleaning of the hull.

- Remove buoyancy tube (for boats with removable buoyancy tubes).
- Wash the deck and hull with soapy soap, rinse with fresh water and dry thoroughly.
- Check the self bailer is not clogged.
- Open the drainage holes caps to evacuate water.
- Reassemble the tube to the hull if necessary and inflate.

MAINTENANCE

1.4 Maintenance of stainless steel

We use only top quality stainless steels, which are resistant to corrosion. However, salt water is a harsh environment and maintenance is required to avoid corrosion.

NOTE:	<p>Stainless steel is not completely immune to corrosion and requires a minimum of care and maintenance:</p> <ul style="list-style-type: none"> • Avoid contamination that results of contact with tools made of ferrous metal: Use chromed tools. • Avoid scoring its surface. • Frequently wash with fresh water. • If necessary, regenerate the protective film with an appropriate product (ask your Dealer).
--------------	--

1.5 Maintenance of the seats and marine plywood floor

Wash the seats and floor with soap and fresh water, and dry thoroughly.

Paints and varnishes not only are decorative elements, they also protect the materials. As soon as you see flakes or scratches on the surface, have it repainted using polyurethane - based products.

2. WINTERING - STORAGE

When storing your boat, keep it in a clean and dry place that is not affected from major variations in temperature and other damaging factors.

You may store the boat:

- Deflated and rolled up in its bag.
- Assembled and slightly inflated.

	<ul style="list-style-type: none"> • For long term storage in the sun (especially in tropical regions), protect your boat with a breathable canvass covering. • RODENTS CHEW ON FABRIC INCLUDING INFLATABLE BOAT MATERIAL. STORE AWAY FROM RODENTS. • IF YOU CHOOSE TO STORE YOUR BOAT INFLATED, MAKE SURE YOU DO NOT SUBJECT IT TO DEFORMATIONS.
---	---

3. REGULAR INSPECTIONS

- Check frequently the signalling, straps and halyards. Replace used elements.
- Check frequently the tightness of the screws and nuts, particularly the motor's bolting to the transom.
- Regularly examine your fuel system, replace old or damaged elements. Check the tightness of the clamping rings.

MAINTENANCE

4. HOW TO REPAIR SMALL PUNCTURES

NOTE:	<p>Your boat is delivered with a repair kit which must be kept on board.</p> <p>Repairs performed while underway can be tricky. Observe the instructions below as far as possible. As soon as you return to shore, redo the repair or have it redone by your dealer.</p>
--------------	--

REPAIR KIT	<p>Cleaning :</p> <ul style="list-style-type: none"> ➤ Grease remover of the alcohol type (not supplied) <p>Repairing:</p> <ul style="list-style-type: none"> ➤ Patch. ➤ Tube of glue or repair patch (Patch'n Go) ➤ Brush (not supplied). ➤ Instruction sheet
CONDITIONS NECESSARY FOR SUCCESSFUL REPAIR	<ul style="list-style-type: none"> ➤ Relative humidity less than 60% ➤ Temperature between 18 and 25°C ➤ Avoid carrying out repairs in direct sunlight or in the rain ➤ Check that the buoyancy tube is fully deflated and lies flat
PREPARATION	<ul style="list-style-type: none"> ➤ Locate leaks (with soapy water if the leak is not visible to the eye) ➤ Cut out a round patch at least 5 cm beyond the tear in the buoyancy tube or use a suitable piece from the repair kit. ➤ Draw the shape of the patch exactly where it will be applied. ➤ Clean the damaged part of the boat and the corresponding side of the patch with a grease remover of the alcohol type ➤ Allow to dry for 5 minutes.
GLUING	<ul style="list-style-type: none"> ➤ Apply 3 thin layers of glue on both the patch and the roughened area on the boat and let dry for 3 to 5 minutes between each layer until tacky.

<p>PUTTING ON THE PATCH</p>	<ul style="list-style-type: none"> ➤ When the 3rd layer is dry, apply the patch without pressing and adjust the position, if required. ➤ Press out the air bubbles which may have formed under the patch. ➤ Smooth the patch with a round object (ex: a spoon) starting from the center of the patch. ➤ Clean the excess glue with a solvent.
<p>USE OF BOAT AFTER REPAIR</p>	<ul style="list-style-type: none"> ➤ Do not expose the repair to sun or rain. ➤ Let dry for 24 hours before inflating.
<div style="text-align: center;">  <p>WARNING</p> </div>	<ul style="list-style-type: none"> - Do not leave the tube in the sun or next to heat sources or direct flames. - Always work in a ventilated area, avoid inhaling glue vapors or swallowing it. Avoid contact with the skin or the eyes.

5. RIGID INFLATABLE BOATS: SMALL REPAIRS ON THE HULL

- The small scratches can be reduced or removed with polish or other appropriate products.
- The deeper scratches can be repaired with polyester mastic or repair gelcoat. In this case, ask your dealer.

<p>NOTE:</p>	<p>For major repairs, take your boat to a dealer who can perform after sales service.</p>
---------------------	---

TROUBLESHOOTING GUIDE

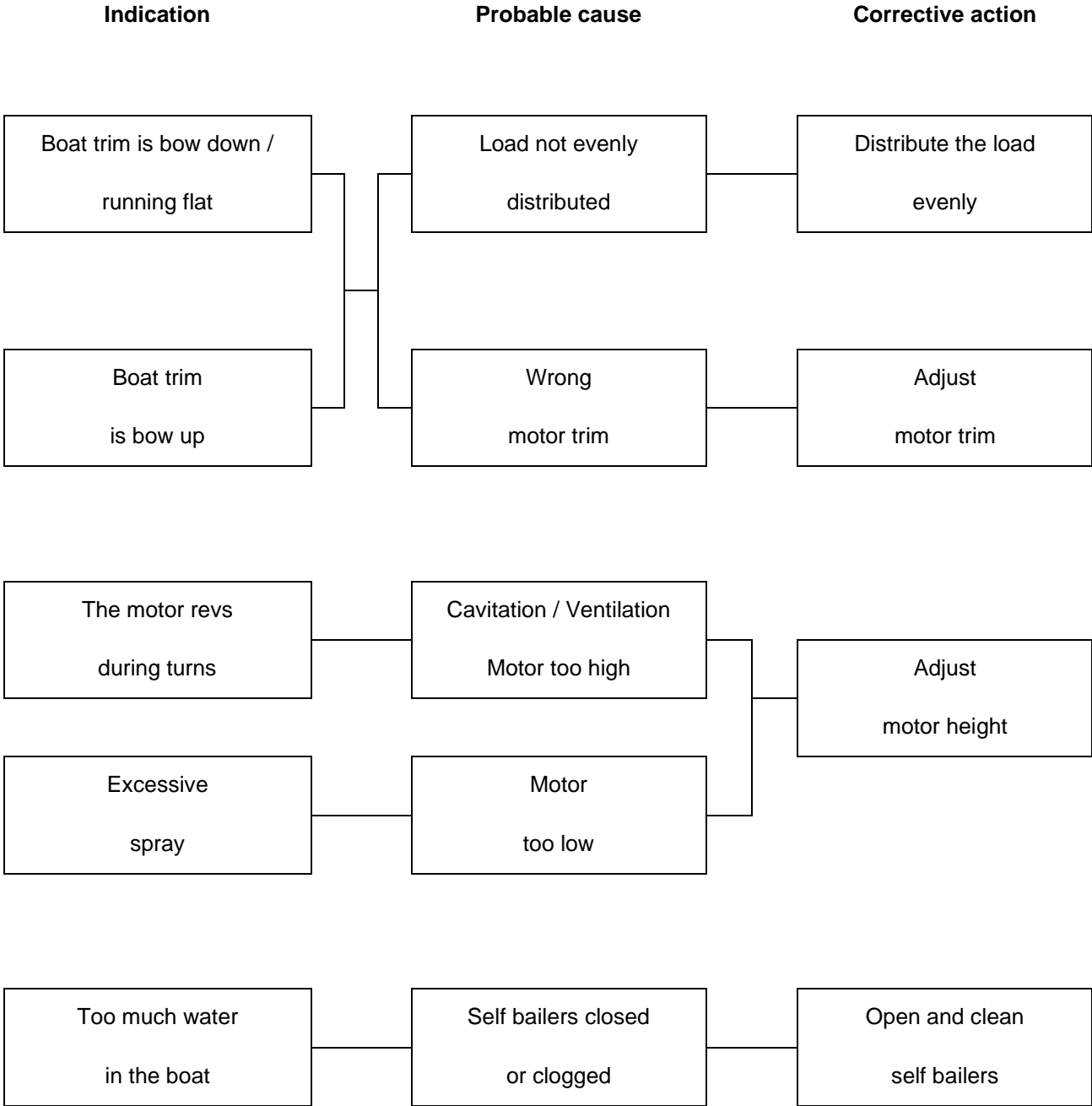

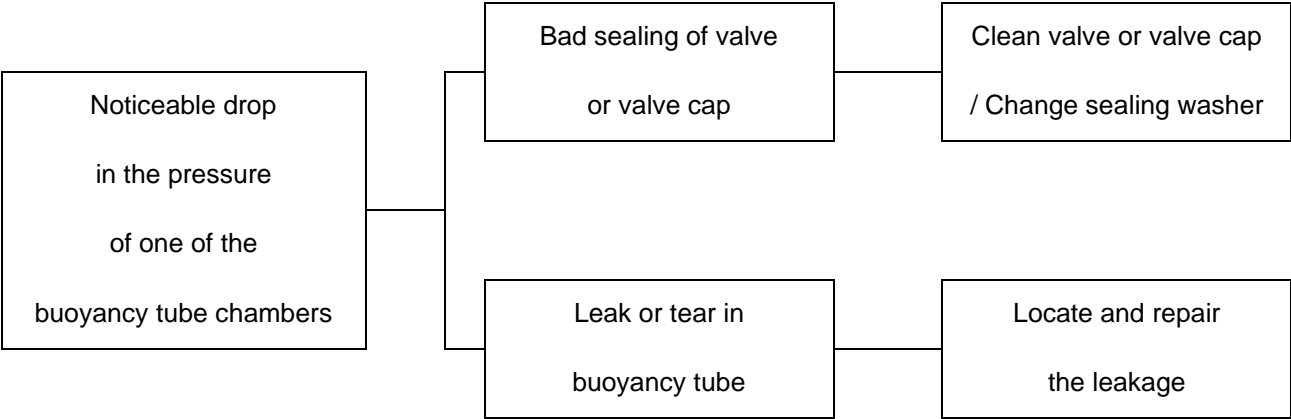
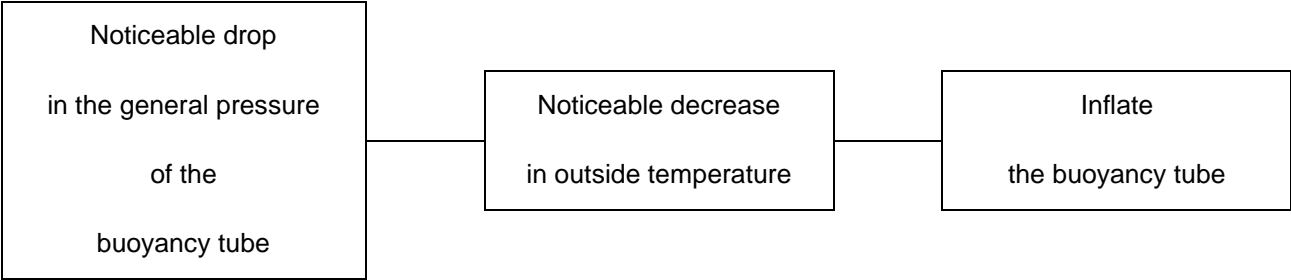

WARRANTY - GENERAL CONDITIONS

NOTE:	<p>Make sure your agent has registered your boat for the manufacturer's warranty. He will inform you about the warranty conditions.</p> <p>All warranty claims must also go through your agent.</p>
--------------	---

The main limitations to the application of this warranty are the following :

- The boat must not be modified and/or fitted with a motor in excess of that allowable by the manufacturer or used in any activities outside normal recreational use (such as races, professional usage).
- Use in excess of the manufacturers recommended maximum load capacity.
- Pressure recommendations, assembly/disassembly and handling procedures must be strictly observed.
- The maintenance and the storage conditions must not be neglected.
- This warranty does not cover parts and accessories not supplied or recommended by the manufacturer or defects resulting from the installation of such equipment on their products.

 WARNING	<p>Your boat is designed in accordance with the standards for a specific use. Any modifications, transformations or use of a motor horse power higher than maximum allowable by the manufacturer could result in serious risks for the user and will void the warranty.</p>
---	--

NOTE:	<p>All repairs covered by warranty must be performed by an authorized dealer.</p>
--------------	--