



Victron VM-3P75CT Energy Meter Manual

Table of Contents

1. Safety Instructions	1
2. Introduction	2
2.1. Features	2
2.2. What's in the box?	3
3. Installation	4
3.1. AC wiring	4
3.2. AC wiring diagrams	5
3.3. Ethernet and VE.Can wiring	6
4. Configuration & Monitoring	7
4.1. LED codes	9
5. Firmware Updates	10
6. Restart and reset to factory defaults	11
7. Troubleshooting	12
7.1. The LED alternates between green and red blinking (bootloader mode)	12
7.2. Error codes	12
7.3. FAQ	12
7.3.1. The current value seems abnormally high for the displayed power	12
7.3.2. The firmware update via the Ethernet connection failed	12
8. Technical data	13
8.1. Technical specifications	13
8.2. Enclosure dimensions	14

1. Safety Instructions

General

Please read the safety instructions below before installing and using the VM-3P75CT energy meter to avoid risks of fire, electric shocks, personal injuries or equipment damage.

This product is designed and tested in accordance with international standards. The equipment should be used for its designated application only and in accordance with the specified operating parameters.

Installation



Installation, maintenance, service and adjustments must be made by qualified personnel only. To reduce the risk of electric shock, do not perform any service other than that specified in the operating instructions unless you are qualified.

- For electrical work, follow the local national wiring standards, regulations and these installation instructions. Connection to the mains supply must be in accordance with the national regulations for electrical installations.
- Never install near fire sources, explosive materials, combustibles or other flammable sources. Never use it at places where gas or other chemical explosions could occur.
- A switch or circuit breaker must be included in the installation. It must be suitably located for easy accessibility and clearly labelled as the designated disconnecting device for the VM-3P75CT.
- Turn off mains power before installing or performing operations on it.
- Do not put fingers or insert objects or sharp metallic objects into the terminals.
- Install it in a dry environment.
- Do not apply strong force on the equipment to prevent crashes and deterioration.
- It is not allowed to use the current clamps on bare wires.
- Make sure the ground connection is properly done to prevent equipment damage.

Operation, service and maintenance

- Do not use the device if it shows any signs of damage or does not function properly.
- Do not use the VM-3P75CT if it is broken, defective, cracked, damaged, or malfunctioning.
- The VM-3P75CT contains no serviceable parts.
- If a current transformer is defective, it must be replaced by qualified personnel.
- Regular maintenance of the VM-3P75CT is not required.
- Avoid moisture, oil/soot/vapours, and keep the device clean.
- Clean using a dry cloth on the front side of the VM-3P75CT.

2. Introduction

The Victron VM-3P75CT energy meter is a standard device to measure the power and energy of single- and three-phase applications and calculates each phase's power values and broadcasts this over VE.Can or Ethernet with a high rate.

It has built-in Ethernet and VE.Can ports for connecting to a GX device and the split-core current transformers enable easy and quick installation without modifying existing wiring.

The energy meter works out of the box (the firmware may need to be updated; details can be found in the [Firmware Updates \[10\]](#) chapter) as a grid meter for systems with a MultiPlus and Quattro. Configuration (via VictronConnect) is only required for changing the role and manual IP configuration rather than the default DHCP.

Its data is displayed on a GX device such as the [Cerbo GX](#) or [Ekrano GX](#), as well as in [VictronConnect](#) and our [VRM Portal](#).

2.1. Features

- Capable of measuring up to $80A_{\text{rms}}$ (Amps root mean square) per phase (but rated at 75A)
- Modbus/UDP communication over Ethernet
- Split-core current transformers for easy installation without modifying the existing wiring
- Uses vector registration method (the vectors of each phase L1, L2 and L3 are summed)
- Status LED can be configured as LED pulse counter for quick diagnostics at a glance



The VM-3P75CT can be configured for four different roles in a GX device, such as the [Cerbo GX](#) or the [Ekrano GX](#):

1. As a Grid meter and used as control input for an Energy Storage System (ESS)
2. To measure the output of a PV Inverter
3. To measure the output of an AC Genset
4. As an AC meter to measure a dedicated AC load circuit

It offers two options for connecting to a GX device:

1. A wired ethernet connection to a local network via its built-in Ethernet port so the GX device can reach it.
2. A wired VE.Can connection via the onboard VE.Can port directly to the GX device.

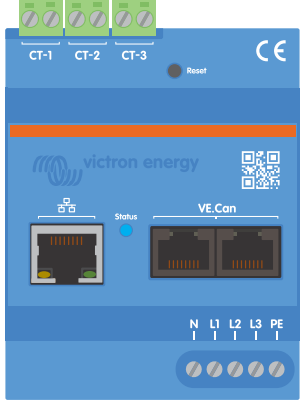
2.2. What's in the box?

<p>Victron VM-3P75CT with 3 input terminal blocks</p>	 <p>The image shows the front panel of the Victron VM-3P75CT energy meter. It features three green CT input blocks labeled CT-1, CT-2, and CT-3 at the top. Below them is a 'Reset' button and a CE mark. The central area has the 'victron energy' logo, a QR code, and a 'Status' indicator. Below the logo are two 'VE.Can' ports. At the bottom, there are four terminal blocks labeled N, L1, L2, and L3, and a PE terminal.</p>
<p>3x Split-core current transformer, wired ready for connection Wire length: 640mm (25.3in)</p>	 <p>The image shows three black split-core current transformers arranged horizontally. Each transformer has a central window for wire and a split core for easy installation.</p>
<p>VE.Can terminators (2 pcs)</p>	 <p>The image shows two blue and grey VE.Can terminators arranged vertically. Each terminator has a grey plastic housing and a blue metal contact point.</p>

3. Installation

3.1. AC wiring

Note the following when installing:

- It is not allowed to use the current clamps on bare wires.
- As the current transformers are quite delicate, the following procedure should be followed when installing the current transformers:

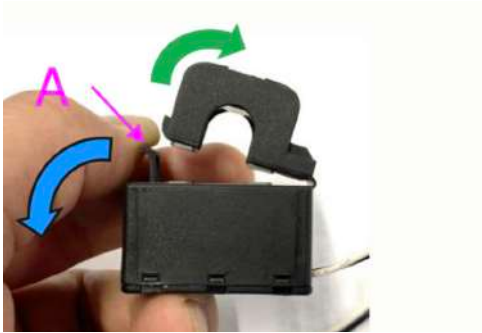

1. First, open Section A. Be careful not to twist the head.
The head part of the product will naturally lift off.
2. Clamp the head part by hand.
3. Make sure the current transformers are connected to the correct phase wire and input terminal. The transformers are marked with an indicator showing which input port they belong to. The devices are calibrated at the factory, and accuracy will decrease if the current transformers are not matched to the correct input.
4. There is an arrow printed on the CT labelled L ← K. Ensure the arrow points towards loads.

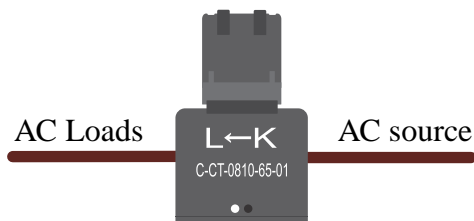

5. Make sure the correct wires are connected to the voltage terminals. The device could be damaged if two phase wires are connected to the neutral and L1 input.
6. In order to isolate the energy meter from power for service or maintenance, a switch or a 2-pole circuit breaker (L1 + N) is required. In addition, a fuse (500mA) is required in the neutral conductor. This can be omitted if the circuit breaker fuse rating is 500mA.

Extending the wires of the split-core current transformers

The wires of the current transformers can be extended if necessary, but note that this will increase the measurement noise slightly.

In general: The longer the cables, the higher the ground floor noise. However, if the length is doubled, the additional error is still low (almost 0A).

To minimise induced noise, it is recommended to twist the wires like the wires supplied with the device.



Should a split-core transformer become damaged, you can order a replacement from your Victron dealer or via [this link](#). Please note that the device is no longer calibrated if the current transformer is replaced.

3.2. AC wiring diagrams

General AC wiring examples

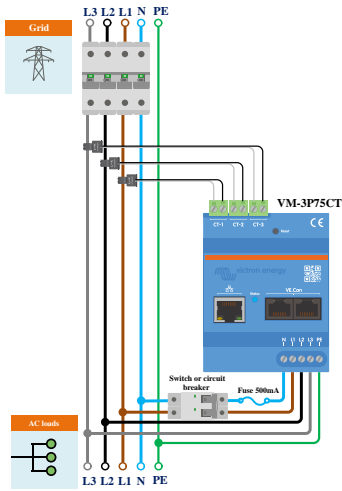

VM-3P75CT 3-phase wiring when used as a grid meter

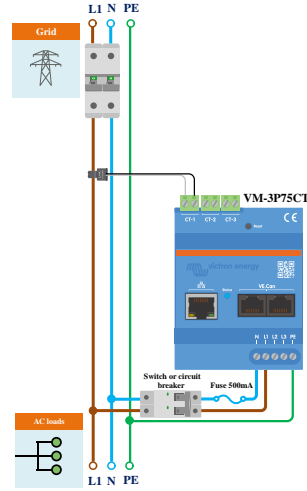

VM-3P75CT 1-phase wiring when used as a grid meter

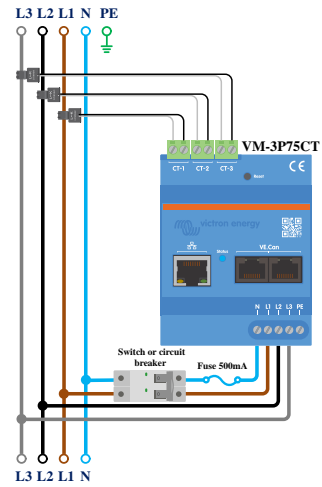

VM-3P75CT 3-phase IT system wiring

Specific AC wiring examples depending on application and role

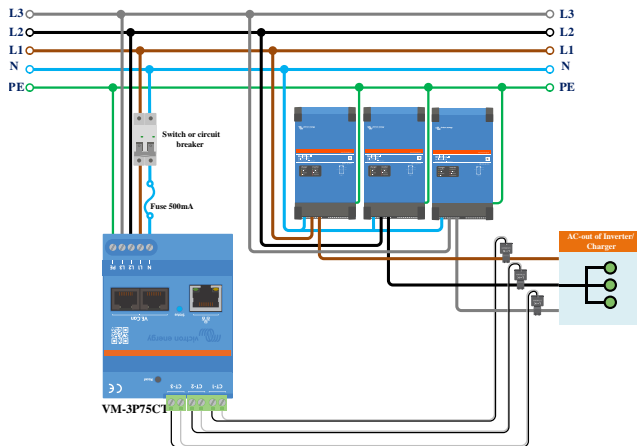

VM-3P75CT 3 Phase Wiring - Role is set to measure AC loads

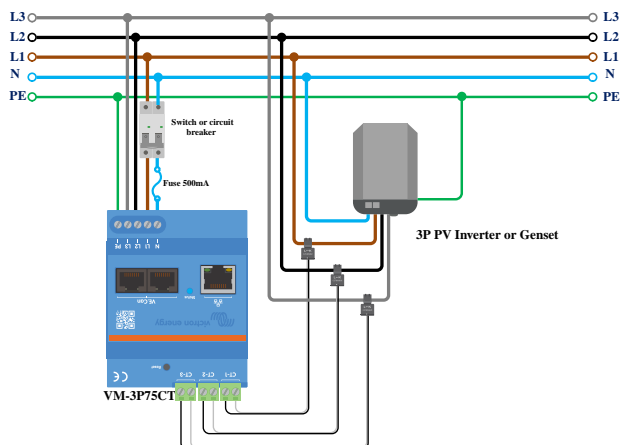

VM-3P75CT 3 Phase Wiring - Role is set to measure a PV Inverter (or Generator)

3.3. Ethernet and VE.Can wiring

The VM-3P75CT can be connected to the GX device either via VE.Can or Ethernet.

Suppose there is a local network with an Ethernet connection (via a router) to which the GX device is connected via Ethernet or WiFi. In that case, connecting the energy meter to the same network via Ethernet is reasonable.

Alternatively, you can connect the energy meter directly to the GX device via its VE.Can connectors. Ensure that the VE.Can network is properly terminated at both ends with the supplied VE.Can terminators.

For both applications, use a good quality Ethernet cable such as the [Victron RJ45 UTP Cable](#), which can also be purchased from your Victron dealer in different lengths.

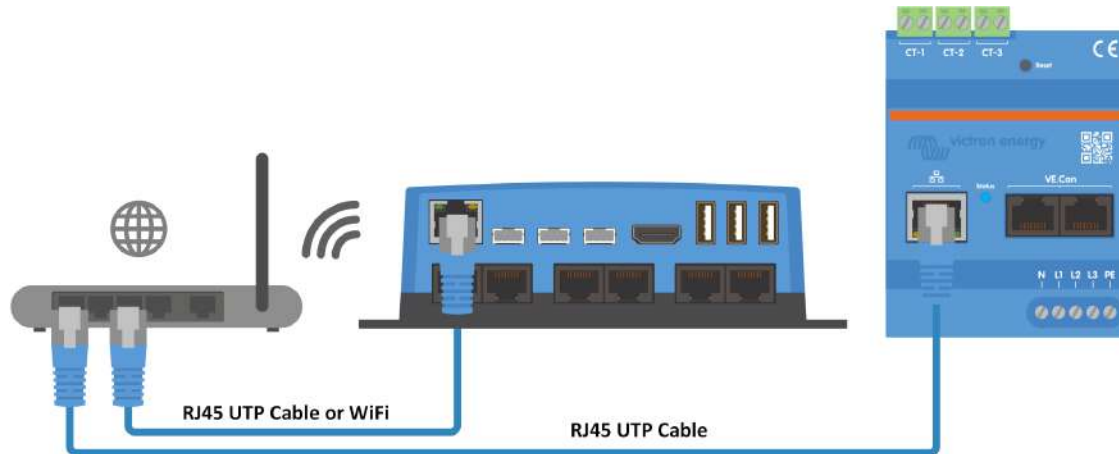

The VM-3P75CT connected to the GX device via Ethernet

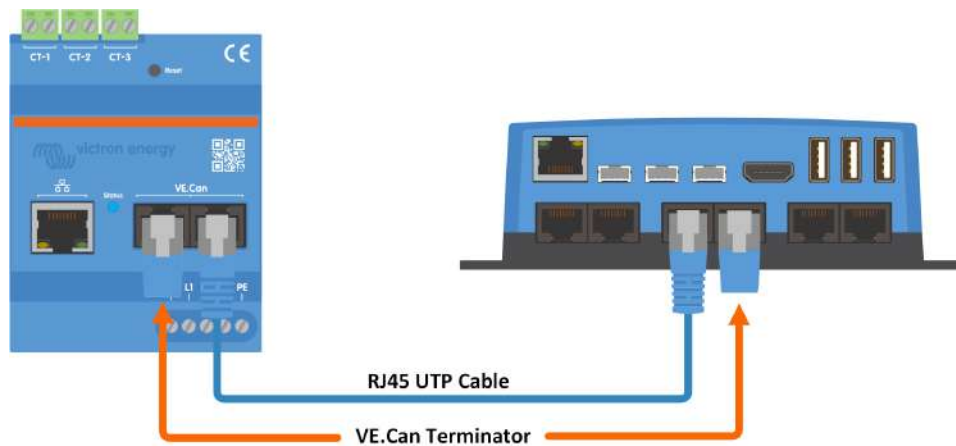

The VM-3P75CT connected to the GX device via VE.Can

4. Configuration & Monitoring

The VM-3P75CT is configured through VictronConnect.

- When using the VE.Can connection, the VM-3P75CT will be automatically detected once connected to the VE.Can port and properly terminated.
- When using the Ethernet connection, the VM-3P75CT is automatically recognised by the GX device.

VictronConnect configuration and monitoring

There are two options to connect to the VM-3P75CT using VictronConnect from a mobile device, laptop or PC:

1. Direct via Ethernet using the Modbus/UDP connection in the local network
2. Or by using [VictronConnect-Remote \(VC-R\)](#) remotely via either VE.Can or Modbus/UDP (requires the GX device connected to the [VRM Portal](#))

The VM-3P75CT supports Instant Readout of key data (total power and power per phase) at a glance directly from the Device list (1) in VictronConnect. This works via a local network connection and VictronConnect-Remote (VC-R).

The data display in VictronConnect is divided into a Status page (2) for status messages of the individual phases and an Energy page (3) with the overview of the fed-in and purchased energy per phase.

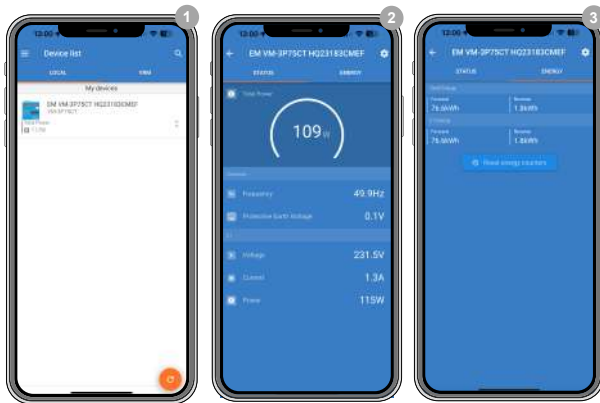

Tapping on the cog wheel in the top right corner of the Status- or Energy page will take you to the Settings page, from where the network settings and the configuration of the meter are made.

The Settings menu (4) includes the following options:

- **Role:** (8) Set this to Grid meter, PV inverter, Generator or AC load, depending on which appliances you want to measure.
- **Phase Configuration:** (7) If the VM-3P75CT is installed single-phase, set it to Only L1. For a 3-phase installation, set it to 3-phase.
- **IP Configuration:** (5) We recommend leaving this setting on Automatic (DHCP). Manual configuration (6) is only necessary in very rare cases. Contact your network administrator for the details.
- **Position:** (9) If a PV inverter is selected as the role, the position must be adjusted depending on where it is connected in relation to the Multi/Quattro AC input or AC output:
- **LED pulse output:** (10) The status LED can be used as an energy pulse signal to enable a visual diagnosis of possible loads at a glance. Each pulse corresponds to a specific amount of energy passing through the meter. Possible options are: Disabled (default), 10 Wh, 100 Wh and 1 kWh.

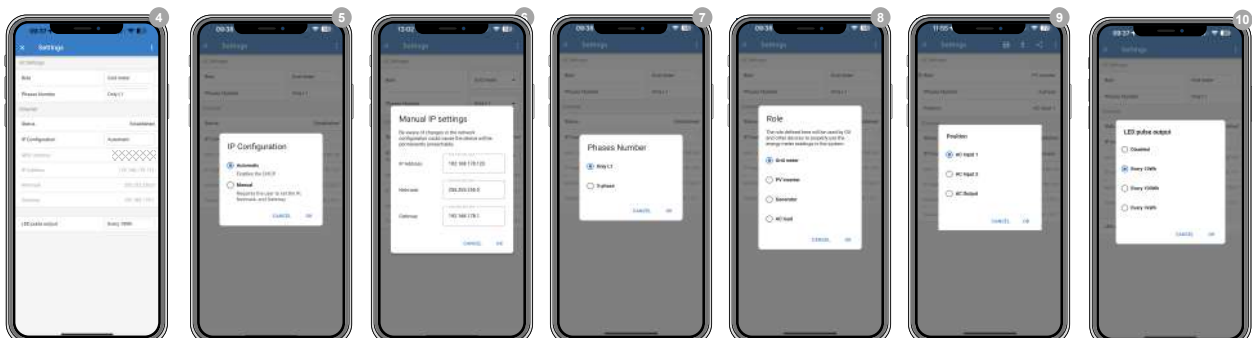

Once the Role has been properly set, the configuration is done.

GX device monitoring

After the VM-3P75CT has established a connection to the GX device in the local network, the device must be activated in the Modbus TCP/UDP menu so that it appears in the Device List.

Go to Settings → Modbus TCP/UDP devices → Discovered devices and enable the discovered energy meter; it's disabled by default when first installed and turned on.



After activation, the energy meter will be displayed in the Device List.

Right-click on the device will take you to the device overview page on which the current data of the individual phases, the AC totals and the total energy per phase can be read out.



An overview of the connection and hardware-specific data can be found on the Device page. There, you can also assign a custom name for the meter.

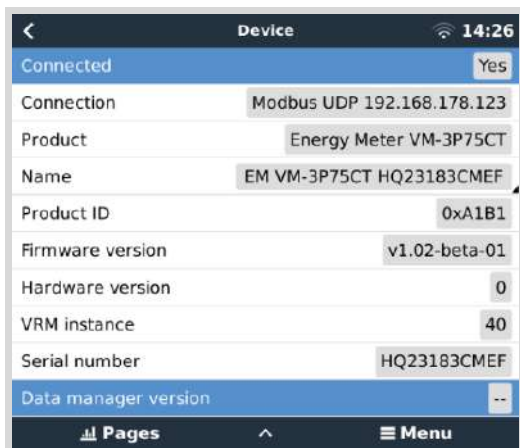

4.1. LED codes

The VM-3P75CT has a built-in LED that shows the status of the energy meter.

The LED states are as follows:

- **Blinking fast alternately green/red:** Bootloader/update mode.
- **Solid green:** All ok, normal running mode.
- **Blinking green @ 1Hz (50% duty cycle):** Identify unit. Stops after 60s.
- **Off for 3 seconds, on for another 10 seconds and off again while pressing the reset button for about 15 seconds:** Reset to factory defaults.
- **Off and immediately on after pressing the reset button briefly:** Restart the device.
- **Solid red:** The LED will illuminate solid red if there is an error.
- **Short red pulse:** Each pulse corresponds to a specific amount of energy passing through the meter. These pulses represent increments such as 0.01 kWh, 0.1 kWh, or 1 kWh.

5. Firmware Updates

The firmware of the VM-3P75CT can be updated in multiple ways:

- [VRM: Remote firmware update](#): This works over Ethernet and VE.Can connection
- [VictronConnect-Remote \(VC-R\)](#): This works over Ethernet and VE.Can connection
- VictronConnect locally via Ethernet/WiFi connection on the local network

6. Restart and reset to factory defaults

The VM-3P75CT has a recessed RESET button that allows you to reset the energy meter to factory defaults or to restart the device if a problem occurs without interrupting the power supply. In addition, a factory reset can also be carried out via VictronConnect.

Restart

To restart the energy meter, briefly press the RESET button. The LED goes off and immediately on again.

Reset to factory defaults

A factory reset resets the following settings to:

- **IP configuration:** Automatic (DHCP)
- **Role:** Grid
- **Phase configuration:** 3-phase
- **Custom name:** VM-3P75CT plus the serial number

Reset to factory defaults step-by-step using the RESET button:

1. Press and hold the RESET button.
The unit resets and will blank the LED for ~3 seconds. The device then restarts, and the LED lights up green again.
2. Keep pressing the button for another ~10 seconds.
After 10 seconds, the LED will go blank again.
3. Release the button.
The device will restart.

Reset to factory defaults step-by-step using the VictronConnect app:

1. Open the VictronConnect app and tap the energy meter you want to reset in the device list.
2. On the status page, tap the gear icon.
3. On the Settings page that opens, tap the 3 vertical dots at the top right.
4. Tap Reset to defaults on the pop-up menu.
5. In the next pop-up menu, confirm the process by tapping on YES.

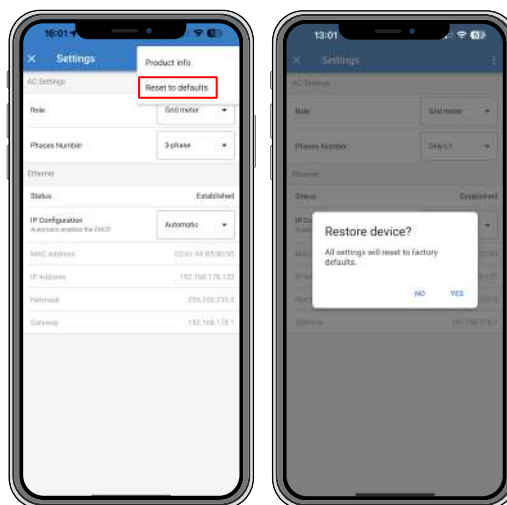

After the factory reset, the energy meter must be configured again as outlined in the chapter [Configuration & Monitoring](#).

7. Troubleshooting

7.1. The LED alternates between green and red blinking (bootloader mode)

There can be two reasons for this behaviour:

1. A firmware update is currently being carried out. Once the firmware update is complete, the energy meter automatically returns to application mode, indicated by a solid green LED.
2. A firmware update was unsuccessful, or there is no application to start. The energy meter remains in bootloader mode until the application has been installed through a firmware update.

To fix this, perform the firmware update again as outlined in the [Firmware Updates \[10\]](#) chapter.



When the energy meter is in bootloader mode, the only available methods for performing a firmware update are through VictronConnect locally (via Ethernet or WiFi) or remotely using [VRM: Remote firmware updates](#) (utilising VE.Can or Ethernet connectivity).

Performing a firmware update via VictronConnect Remote (VC-R) in bootloader mode is impossible.

7.2. Error codes

The VM-3P75CT indicates an error by turning the LED solid red when an error is present. Simultaneously, an error code appears on the GX device, VRM, and VictronConnect.

The following error codes can be displayed:

- **116 - Calibration data lost**

If the unit does not work and error 116 pops up as the active error, the unit is faulty. Contact your dealer for a replacement.

- **119 - Settings corrupt**

The energy meter cannot read its configuration and stopped.

To fix the error, perform a factory reset as described in the [Restart and reset to factory defaults \[11\]](#) chapter.

- **122 - kWh counters corrupt**

To fix this error, reset the kWh counter.

7.3. FAQ

7.3.1. The current value seems abnormally high for the displayed power

The energy meter calculates each phase's power in Watts (P), and the active (real) power is displayed. Active Power is the product of the voltage, the current, and the power factor, where the power factor is traditionally denoted by $\cos(\theta)$. In a system with unity power factor, that is where $\cos(\theta)=1$, the real power will be equal to the apparent power, the product of the RMS-voltage and current.

In most electrical systems there will also be a reactive power, caused by the existence of inductive and/or capacitive loads. In such systems, the power factor will be less than unity, and the apparent power will always be more than the real power.

In AC systems, it is therefore normal and even expected for the apparent power (S), that is the RMS-voltage multiplied by the current, to be higher than the real power (P).

Many smaller electronic devices, including USB chargers and LED lighting, can have a particularly poor power factor, which will lead to a large difference between P and S. This condition is often exacerbated by the installation of renewable energy generation devices since such devices are legally required to operate at near-unity. The larger renewable generation tends to cancel out all the good power factor, leaving behind only the poor power factor caused by the loads.

If the power factor is a concern, the solution is to look at power factor correction equipment, or to invest in loads that have better power factor. Switch mode power supplies for personal computers often have power factor correction built-in already.

7.3.2. The firmware update via the Ethernet connection failed

If you encounter problems updating the VM-3P75CT's firmware via Ethernet, try connecting it to the GX device via VE.Can (see the [Ethernet and VE.Can wiring \[6\]](#) section for details), perform the update again as outlined in the [Firmware Updates \[10\]](#) chapter, and then reconnect via Ethernet.

8. Technical data

8.1. Technical specifications

VM-3P75CT	REL200300100
VOLTAGE INPUTS	
Voltage connection	Direct
Input voltage range L-N	85 to 265VAC
Input voltage range L-L	150 to 460VAC
Frequency	50/60Hz
CURRENT INPUTS	
Current connection	Via current transformers (included - wire length 640mm (25.2in))
Rated current	75A
COMMUNICATION	
VE.Can communication port	Two RJ45 connectors (VE.Can terminators included)
Ethernet communication port	One RJ45 connector, Modbus UDP
Refresh rate	100ms
POWER SUPPLY	
Type	Self-power supply via L1-N
Switch or circuit breaker	Required as means of a disconnecting device - not included
External fuse ^[1]	Required in the neutral conductor - 500mA, not included
Consumption	1.45W / 3.1VA
Frequency	50/60Hz
ENCLOSURE	
Material & colour	Polycarbonate, blue (RAL5012)
Voltage connection	Screw terminals 0.25 - 1.5mm ² (24 - 16AWG)
Current transformer connection	Pluggable screw terminals (included)
Protection category	IP20
Weight	370g (including packaging)
Dimensions	90 x 71 x 59mm (3.5 x 2.8 x 2.3in)
ENVIRONMENTAL	
Indoor/outdoor usage	Indoor only
Operating temperature	From -10 to +55 °C
Storage temperature	From -20 to +70 °C
Relative humidity	< 90% non-condensing
Altitude	2000m (6562ft)
Mains supply voltage fluctuations	±0.1Vin
Overvoltage category	Cat. III
Pollution degree	2
STANDARDS	
Safety	EN-IEC 61010-1
^[1] Can be omitted if a circuit breaker with a fuse rating of 500mA is used as the isolating device.	

8.2. Enclosure dimensions

