

XB-6000 | XB-8000 Install Guide



vespermarine

Your XB-6000 / XB-8000 is a Class B AIS Transponder with NMEA gateway and integrated NMEA 2000 and WiFi*.

The XB provides information to improve your situational awareness and assist in avoiding collisions at sea. Because it consumes very low power it may be left turned on whenever your vessel is underway. It works by interpreting Universal Shipborne Automated Identification System (AIS) messages which are sent over VHF by transponders installed on other vessels. The AIS system uses two dedicated VHF channels designated for this purpose and with the installation of the XB to receive these signals, you can distribute this information to other devices on board your vessel (e.g. chart plotters, laptops, smart phones) using NMEA 2000, USB and WiFi*. In addition, your vessel position and other data is transmitted to all other AIS-equipped vessels within range.

For more information on go to www.vespermarine.com/xb.

WHAT YOU NEED TO GET GOING

- XB-6000 or XB-8000
- External GPS Antenna with 10m cable
- 10 pin power/data cable
- AIS/VHF antenna
- MMSI number
- PC, Mac or Mobile Device (Apple or Android)* for configuring settings
- 2A fuse or circuit breaker

OPTIONAL ACCESSORIES

- 1m USB cable (for configuration)
- Waterproof 5m USB cable with locking security ring
- NMEA 2000 cable, T connector and network extension cable
- SP160 Antenna Splitter
- External alarm buzzer for MOB or anchor watch alarms*
- Switch for silent mode or to silence MOB or anchor watch alarms*

Consider other equipment you may need to install this on your vessel e.g. additional cable, cable ties, mounting screws, wire strippers, screw driver etc.

✓ = Item Included

(*XB-8000 only)

CONNECTIONS

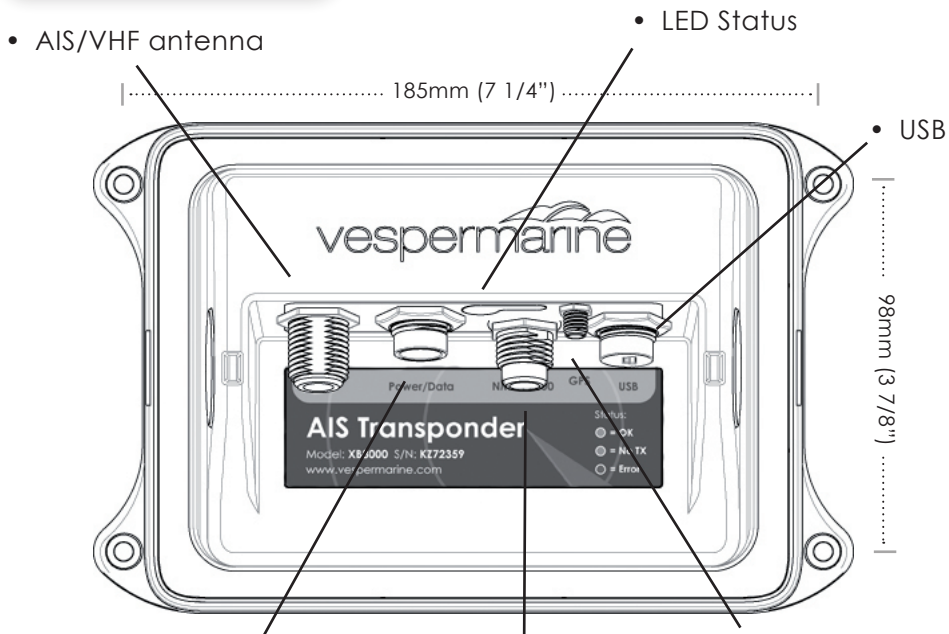

- AIS/VHF antenna
- LED Status
- USB
- 10 pin power/data port
- NMEA 2000
- GPS antenna

Mount your XB at least 0.6m (2 feet) from any compass. Test your compass to verify that it operates properly when the XB is operating.

STATUS LED

COLOR	STATE	DESCRIPTION
Green (OK)	Solid	Normal Operation
	Flashing	Antenna VSWR is high
Background noise level on AIS receiver is high		
Orange (No Transmit)	Solid	Device initializing, silent mode, waiting to transmit
	Flashing	Acquiring a GPS fix
Red (Error)	Solid	Built in integrity test error or firmware update in progress

(See troubleshooting section for more info)

VHF ANTENNA

- A dedicated VHF antenna or Vesper Marine AIS/VHF Antenna Splitter is required.
- Choose a high quality omnidirectional VHF antenna designed for the marine band (156-162MHz) and ensure it is well tuned at the AIS end of the band (VSWR 2:1 or less at 162MHz).
- Mount the antenna as high as possible (at least 2-3 metres (6-10 ft) above the water surface). It is not recommended to place the VHF antenna near a mast or other metal structures.
- For best performance avoid using small helical "rubber duck" style antennas.



CAUTION: Install the antenna a minimum of 1m (4 ft) from any other VHF or HF antennas and not within the beam path of a radar. Inadequate separation may damage the XB transponder and void your warranty.



CAUTION: Never operate this device unless it is connected directly to a suitable VHF antenna or Vesper Marine AIS/VHF Antenna Splitter.



CAUTION: The Vesper Marine AIS/VHF Antenna Splitter is designed specifically for use with Vesper Marine AIS transponders. Do not use any other VHF antenna splitter. The use of any other splitter may damage the device and void your warranty.



HINT: Use the VSWR meter in vmAIS or the WatchMate app (see configuration section) to check your antenna system installation.

GPS ANTENNA

- The XB requires a GPS fix before it can transmit its position.
- You cannot share an external GPS antenna.
- You cannot use another GPS or any other NMEA device to provide a GPS position to the XB. Class B AIS transponders are required by international regulations to use their own GPS.
- However, you can use the XB to provide GPS position data to other devices using NMEA 0183, NMEA 2000, USB or WiFi (XB-8000)



CAUTION: The Vesper Marine GPS antenna is designed specifically for use with Vesper Marine AIS transponders. Performance cannot be assured unless you use a Vesper Marine GPS antenna. Use of a different GPS antenna may damage the XB transponder and void your warranty.

GPS ANTENNA

Internal (XB-6000 only)

The XB-6000 has a built-in GPS antenna.

- This antenna requires an unobstructed view of the sky.
- The antenna performance may be significantly reduced if the XB-6000 is installed on, under, or near large metal structures.
- The antenna faces upwards and is located as shown in the drawing.
- If you are mounting the XB-6000 in a location which will not provide adequate GPS signal coverage, then you must install the dedicated GPS antenna provided.

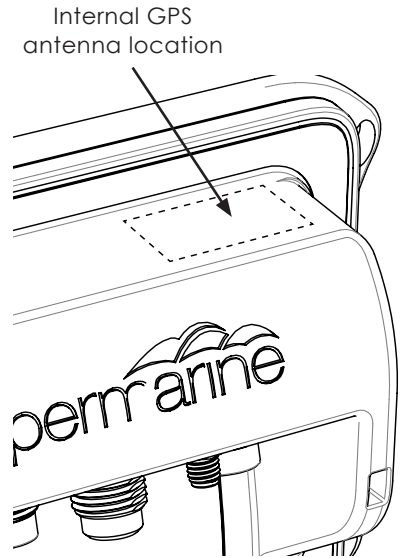

External GPS Antenna

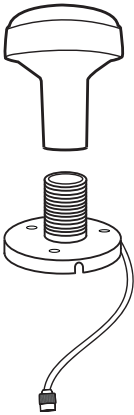

The XB-8000 requires installation of the dedicated GPS antenna provided. This may also be required for the XB-6000 if the internal antenna does not provide adequate GPS signal coverage.

- The GPS antenna should be situated so that it has an unobstructed view of the sky above.
- Do not place the GPS antenna near or in the path of radar or HF antennas.
- You cannot share the GPS antenna with any other device.
- The antenna cable is terminated with a small SMA connector to facilitate easy routing through holes and openings. Do not cut the cable unless you have the proper tools to crimp a new connector. Make the connection to your AIS transponder last after antenna installation is complete.



HINT: Use the GPS Status screen in the vmAIS PC/Mac Configuration and Status software or the WatchMate Apple* or Android app* to view the satellite signal strengths which will assist in determining the best location for mounting the XB-6000 or the external GPS antenna for both the XB-6000 and XB-8000 (see configuration section).

(*XB-8000 only)

NMEA 2000

The XB can be connected to a NMEA 2000 network to enable AIS and GPS data to be sent to other NMEA 2000 devices. The XB can also receive and make use of data sent from NMEA 2000 sensors.

- Data Packets (PGN's) supported are defined below.
- A drop cable, T connection and network extension cable are required to connect the XB to your NMEA 2000 network.

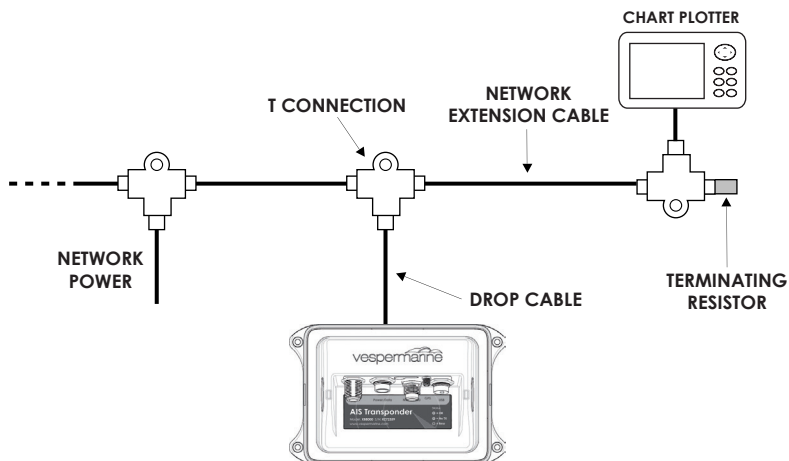

PGNs Received

Received PGN's are translated and output on the NMEA 0183, USB and WiFi* ports. See www.vespermare.com/xb for an up-to-date list.

PGN	DESCRIPTION	NMEA 0183 TRANSLATION
127250	Vessel Heading	HDG
128259	Speed	VHW
128267	Water Depth	DPT
128275	Distance Log	VLW
130306	Wind	MWD, MWV
130310, 130311 130312, 130316	Water Temperature	MTW

PGNs Sent

- | | |
|---|---|
| 129025 Position (Rapid) | 129041 AIS Aids to Navigation |
| 129026 COG & SOG (Rapid) | 129794 AIS Class A Static Voyage |
| 129029 GNSS Position | 129798 AIS SAR Aircraft Position |
| 129540 GNSS Satellites | 129801 AIS Addressed Safety |
| 129038 AIS Class A Position | 129802 AIS Safety Related Broadcast |
| 129039 AIS Class B Position | 129809 AIS Class B "CS" Static, Part A |
| 129040 AIS Class B Extended Position | 129810 AIS Class B "CS" Static, Part B |

(*WiFi on XB-8000 only)

POWER AND DATA

A 2m (6.5ft) cable with attached 10 pin plug is supplied for connecting the XB to power, other devices over NMEA 0183, an external switch and external alarm*. You may extend this cable as necessary.

- Check you have the VHF antenna connected before connecting to power.
- Fully engage the locking ring to ensure a watertight seal.

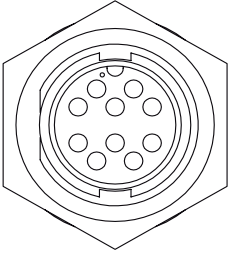

HINT: Silent Mode can also be controlled over USB and WiFi*. External switch is an optional manual override.

HINT: External alarm may also be silenced using the WatchMate mobile apps.

COLOR	DESCRIPTION
Red	DC positive (+) (12-24 volts). Always use a 2A fuse or circuit breaker. Do not connect directly to battery. If you must extend the power connections use high quality pre-tinned marine grade wire which is at least 16 AWG (1.5mm²) .
Black	DC negative (-)
Gray	NMEA 0183 out (+) A
Yellow	NMEA 0183 out (-) B
Green	NMEA 0183 in (+) A Received data is output on WiFi*, USB & 0183
White	NMEA 0183 in (-) B
Brown	External switch configured for silent mode or to silence alarm*. Do not connect if not used.
Blue	External alarm (limited to 150mA)* Do not connect if not used.

Do not connect orange or pink wire

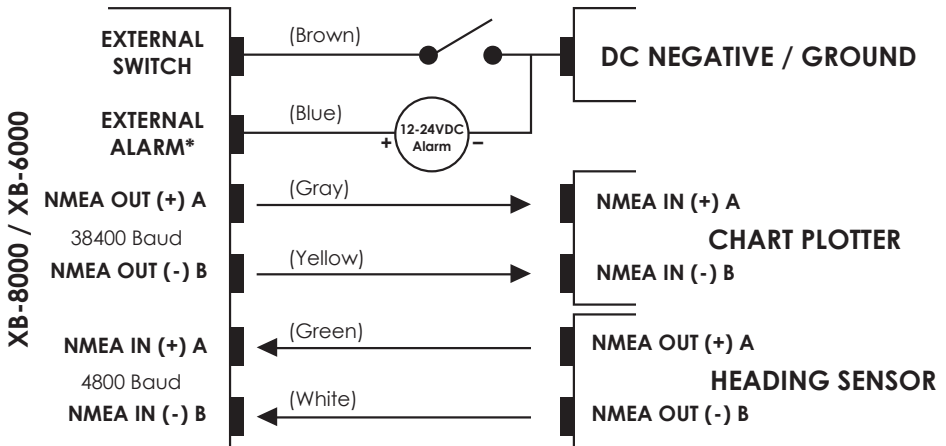

(*XB-8000 only)

WiFi (FOR XB-8000 ONLY)

Access Point Mode (default)

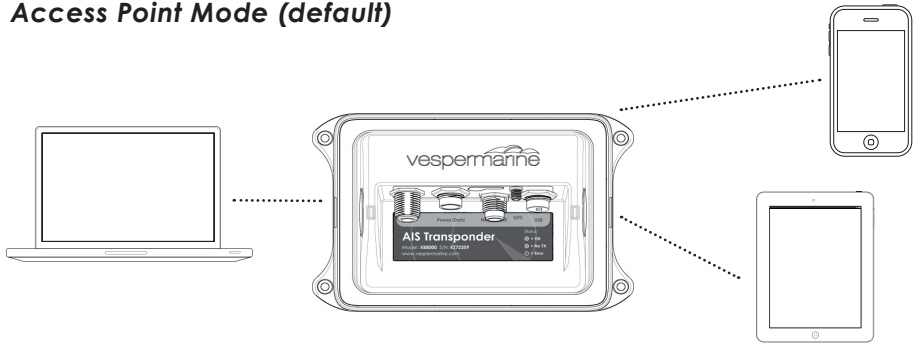

The XB-8000 will control your onboard WiFi network of up to 5 devices.

You can connect to the XB-8000 using:

- Network (SSID): **VesperXB-xxxxxx (serial number)**
- Password: **WatchMate**

We recommend that you change your password straight away and write it down here for future reference: _____ . You can recover your password over USB if you forget it.

- The default IP address that mobile apps may need is **192.168.15.1 (Port 39150)**.

Client Mode

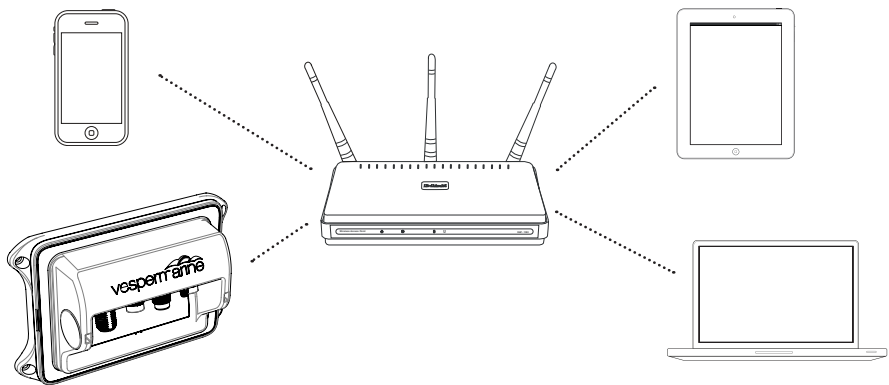

The XB-8000 can also join an existing network. It can do this in either DHCP mode (default) or you can set a static IP address using vmAIS (see configuration section). To prevent the address from automatically changing we recommend that you use a static IP address.

CONFIGURATION

- Before the XB can transmit your position you must configure your vessel details and enter a valid MMSI number. Your MMSI may have been entered already by your dealer. **You must have an assigned MMSI for your vessel.** If you do not have an assigned MMSI, contact the relevant authority in your country.
- You can configure your XB using the WatchMate App* or the vmAIS PC/Mac software. These are available for download from **www.vespermarine.com/xb**.
- With vmAIS you can connect to the XB using either the USB COM port or over WiFi* by entering the IP address (192.168.15.1 default). Click the **Connect** button. Allow 30 seconds for the XB to initialize after power on before attempting to connect.

Com Port: COM10 IP Address: Port:

Model: XB8000 Version: 5.06 (1.03.4789)
Serial Number: KW74131 Revision: 4993M

Configure Vessel Data | WiFi | NMEA2000 | Status | GPS | Firmware Update | Serial Data

MMSI

Name

Call Sign

Type:

Diagram showing GPS ANTENNA location on a boat with dimensions A, B, C, and D.

Units: Metres Feet*

* Data is always stored in whole metres. Therefore not all dimensions in feet can be represented.

- **Once you save the MMSI number you cannot change it.** If you need to change the MMSI, please contact an authorized dealer or Vesper Marine.
- When all the information is correct, click on the Save Vessel Data button.
- You can also change your WiFi* settings, view your GPS signal strength, Transponder status and VSWR level using vmAIS.

*(XB-8000 only)

USB

- When you connect the XB to your PC or Mac using USB, it will automatically create a COM port (see configuration section). This COM port may then be used with the vmAIS utility or 3rd party navigation software. Download vmAIS from www.vespermarine.com/xb.
- The first time you plug it in, most operating systems will automatically install the necessary drivers.
- If a COM port is not created the first time you plug it in, you may need to install the drivers manually. Download the USB drivers from www.vespermarine.com/xb.

YOU'RE FINISHED!

If the Status LED is solid green, the XB is transmitting your position and is successfully installed! Your position will be transmitted every 3 minutes when your speed is under 2 knots or every 30 seconds otherwise. Your vessel information (e.g. name, callsign, etc) is transmitted every 6 minutes. If the Status LED is not solid green yet, see the troubleshooting section for the probable cause.

GOT A QUESTION?

Visit www.vespermarine.com/xb for comprehensive answers to frequently asked questions, technical support, downloads, local dealer contacts and more...

REGISTER YOUR XB

Vesper Marine releases downloadable updates from time to time. These updates often add new features. To be notified when a new update is available please register your XB at www.vespermarine.com/register.

STATUS LED TROUBLESHOOTING

COLOR	STATE	DESCRIPTION
Orange	Solid	<p>Device initializing</p> <p>Before the XB can transmit it needs 1 minute to initialize.</p>
		<p>MMSI not programmed</p> <p>You must have a valid MMSI programmed before you can transmit your position (see configuration section).</p>
		<p>Silent mode</p> <p>Silent mode is on. If this is not intentional check the brown wire has not been accidentally connected to DC negative or vessel ground.</p>
		<p>Last position report not sent</p> <p>This may happen from time to time in very busy areas with lots of AIS traffic. This is normal behavior for a Class B AIS device.</p>
	Flashing	<p>Acquiring a GPS fix</p> <p>The XB requires a GPS fix before it can transmit its position. This may take a few minutes. If it is taking a long time check your GPS antenna installation (see GPS antenna section) and GPS signal strength using vmAIS or WatchMate app.</p>
Green	Flashing	<p>Antenna VSWR is high</p> <p>Check your antenna installation. Use the VSWR meter in the vmAIS status page or WatchMate app. A poorly tuned antenna, bad cabling or connections are typical reasons for a high VSWR. Your XB will continue to operate normally but transmit performance will degrade.</p>
		<p>Background noise level on AIS receiver channel is high</p> <p>An AIS receiver channel has an abnormally high background noise level. Determine the channel and frequency by using the vmAIS status page or WatchMate app. Look for an RSSI level greater than -77dBm. Remove any sources of noise onboard at this frequency. Your XB will continue to operate normally but receive performance will degrade.</p>
Red	Solid	<p>Built in integrity test error (or firmware update in progress)</p> <p>An internal error has been detected. The XB may automatically recover, but if the error state persists contact our technical support team for assistance by visiting our support site at support.vespermarine.com.</p>

TECH SPECS

Size	200mm wide x 130mm high x 60mm depth (7 7/8" x 5 1/8" x 2 3/8")
Power supply	10-32 VDC 2A max, 3W nominal
Environmental	Waterproof (IPx7)
Operating temperature	-25°C to +55°C (-13°F to 131°F)
Storage temperature	-25°C to +80°C (-13°F to 176°F)
Serial data	1 USB port (isolated), 1 NMEA input (isolated RS422), 1 NMEA output (non-isolated RS422)
Data port impedance	NMEA input: 96k ohm, NMEA output: 28 ohm
NMEA 0183 output	RMC, GSV, GSA, GGA, GLL, VTG, VDO, VDM, TXT, DSC, HDG, VHW, DPT, VLW, MWD, MWV, MTW, APB, BOD, BWC, BWR, BWW, XTE, WPL
NMEA 0183 input	HDG, HDM, HDT (These are processed, but are not required. Other sentences are not processed but all valid NMEA sentences are output on NMEA 0183, WiFi* and USB)
Number of receivers	2 AIS, 1 DSC (timeshared)
Number of transmitters	1 AIS
Receive frequency range	156.025 – 162.025 MHz
Transmit frequency range	161.500 – 162.025 MHz
AIS sensitivity	-113 dBm < 20% PER
Power output	33 dBm (2W)
GPS sensitivity	-159dBm tracking & navigation -142dBm acquisition
GPS SBAS support	WAAS, EGNOS, MSAS, GAGAN
External alarm maximum	150 mA @ VDC
Power/data connector	10 pin circular
USB connector	Mini USB (USB 2.0)
GPS antenna connector	SMA
VHF antenna connector	SO-239
VHF antenna required	50 ohm, max 2:1 VSWR @ 162MHz. PL-259 connector
NMEA 2000 connector	NMEA 2000 Micro-C male
Firmware version	5.16
Wireless *	802.11 b/g in Access Point or Client Mode, 10mW.
Access point security *	WPA2 Personal
Client mode security *	None, WPA & WPA2 Personal

(*XB-8000 only)

WARNINGS

This AIS Transponder works in conjunction with other vessels and systems such as other AIS transponders and GPS devices. The accuracy of this device and the AIS system can be affected by many factors, including equipment failure or defects, environmental conditions and incorrect installation, handling or use. Vesper Marine does not warrant that this product is error-free. It is the user's responsibility to exercise common prudence and navigational judgement. This device should not be relied upon as a substitute for such prudence and judgement. Always maintain a permanent watch so that you can respond to situations as they develop. The prudent mariner will not rely on a single aid to navigation. The user should verify the information obtained from this AIS Transponder is in accordance with expected situations and conditions. The information is not guaranteed to be accurate or reliable and this AIS Transponder is not a substitute for proper seamanship. Vesper Marine Limited cannot be held liable for any injury, damage or loss, caused by, during, or because of the installation, use or inability to use this device. This AIS Transponder is to be installed and used entirely at your own risk. By installing and/or using this AIS Transponder you fully accept this risk and agree to hold Vesper Marine Limited harmless. If you do not agree to accept all risk, return this product unused in its original factory condition to your dealer for a full refund.

Intended Use

This product is intended to be used on leisure or commercial vessels (excluding IMO/SOLAS class). Vesper Marine has designed and manufactured this product to be used only aboard vessels.

Warranty Void

Do not disassemble the unit or remove the screws which hold it together. The unit is sealed and disassembly will void the warranty.

FCC Warning:

This device complies with Part 15 of the FCC Rules. Operation is subject to the following two conditions: (1) this device may not cause harmful interference and (2) this device must accept any interference received, including interference that may cause undesired operation.

Industry Canada Warning:

This device complies with Industry Canada license-exempt RSS standard(s). Operation is subject to the following two conditions: (1) this device may not cause interference, and (2) this device must accept any interference, including interference that may cause undesired operation of the device.

This device complies with RSS-310 of Industry Canada. Operation is subject to the condition that this device does not cause harmful interference.

To satisfy RF exposure requirements for mobile transmitting devices, a separation distance of 1 metre or more should be maintained between the antenna of this device and persons during device operation. To ensure compliance, operations at closer than this distance is not recommended.

The antenna used for this transmitter must not be co-located in conjunction with any other antenna or transmitter.

This device has been designed to operate with an antenna having a maximum gain of 3dBi. Antennas having a gain greater than 3dBi are strictly prohibited for use with this device. The required antenna impedance is 50 ohms.

To reduce potential radio interference to other users, the antenna type and its gain should be chosen that the equivalent isotropically radiated power (EIRP) is not more than that required for successful communication.

Pour satisfaire aux exigences d'exposition aux fréquences radio pour les appareils mobiles de transmission, une distance de 1 mètre ou plus doit être maintenue entre l'antenne de ce dispositif et les personnes pendant son fonctionnement. Pour assurer la sécurité, les opérations plus près de cette distance ne sont pas recommandées.

L'antenne utilisée pour ce transmetteur ne doit pas être co-localisée avec toute autre antenne ou transmetteur.

Ce dispositif a été conçu pour fonctionner avec une antenne ayant un gain maximal de 3dBi. Les antennes ayant un gain supérieur à 3dBi sont strictement interdites pour une utilisation avec cet appareil. L'impédance d'antenne requise est de 50 ohms.

Pour réduire le risque d'interférence aux autres utilisateurs, le type d'antenne et son gain doivent être choisis pour que la puissance isotrope rayonnée équivalente (PIRE) ne soit pas supérieure à celle requise pour une communication réussie.

MMSI Programming Warning

IMPORTANT: In most countries the operation of an AIS unit is included under the vessel's marine VHF license provisions and the vessel on which this device is to be installed may be required to possess a current VHF radiotelephone license which lists the AIS system and the vessel Call Sign and MMSI number.

An MMSI number is required in order for this device to operate as a transmitter.

Please contact the relevant authority in your country for more information.



AT	BE	BG	CY	CZ	DE	DK	EE	ES	EL
FI	FR	HR	HU	IE	IT	LT	LU	LV	MT
NL	PL	PT	RO	SE	SI	SK	UK		

For Customers in the USA

This device must be programmed with data corresponding to the vessel on which it will be installed. Programming must be carried out by a Vesper Marine dealer. The included instructions contain information on how to verify the correct programming.

WARNING: It is a violation of the rules of the Federal Communications Commission to input an MMSI that has not been properly assigned to the end user, or to otherwise input any inaccurate data in this device.

RF Emissions Warnings



CAUTION: This device generates and radiates electromagnetic energy. This device must be installed and operated according to the instructions contained in this manual. Failure to do so may result in product malfunction and / or exposure to potentially harmful levels of radio frequency radiation. Changes or modifications to the unit not expressly approved by Vesper Marine Ltd will void the user's authority to operate this equipment.



CAUTION: The system has a Maximum Permissible Exposure (MPE) radius of 1m from the antenna. This has been determined assuming the maximum power of the transmitter and using a standard half-wave monopole VHF antenna with a maximum gain of 3dBi and termination impedance of 50 ohms.

When installing the antenna and operating the equipment consider the following:

- The antenna should be mounted as high above deck as possible.
- Higher gain VHF antennas will require a larger MPE radius.
- Do not operate the unit when anyone is within the MPE radius of the antenna.
- The antenna should not be collocated or operated in conjunction with any other transmitting antenna.

WARRANTY

Your Vesper Marine AIS transponder is warranted, when properly installed and used, to be free from defects in materials or workmanship for two years from the date the product was purchased by the first retail customer. This warranty applies to the original retail purchaser only and is not transferable. This warranty only applies to products purchased from Vesper Marine or from an authorized Vesper Marine reseller. Within this period, Vesper Marine will, at its discretion, repair or replace any components which fail in normal use. Repairs or replacement will be made at no charge for parts or labor, provided that the customer shall be responsible for any transportation costs. This warranty does not cover failures due to abuse, misuse, accident, improper installation, unauthorized alterations or repairs, shipping damage, wear and tear, or corrosion.

This warranty will not apply if the product's external housing has been opened, the serial number or other labels have been removed or altered, or the specified input voltage has been exceeded. This warranty will not apply if the product has been operated with an incompatible GPS antenna or without a suitable VHF antenna, or with an incompatible antenna splitter, where applicable to the product.

Vesper Marine retains the exclusive right to repair or replace the unit at its sole discretion. In the event Vesper Marine chooses to replace the unit it may be replaced with a factory reconditioned unit or a new unit at its sole discretion. Where a replacement is provided the original product becomes the property of Vesper Marine and the warranty will remain from the original purchase date.

THE WARRANTIES AND REMEDIES CONTAINED HEREIN ARE EXCLUSIVE AND IN LIEU OF ALL OTHER WARRANTIES, WHETHER EXPRESS, IMPLIED OR STATUTORY, INCLUDING ANY LIABILITY ARISING UNDER ANY WARRANTY OF MERCHANTABILITY OR FITNESS FOR A PARTICULAR PURPOSE, STATUTORY OR OTHERWISE. THIS WARRANTY GIVES YOU SPECIFIC LEGAL RIGHTS, WHICH MAY VARY FROM STATE TO STATE.

IN NO EVENT SHALL VESPER MARINE BE LIABLE FOR ANY INCIDENTAL, SPECIAL, INDIRECT, OR CONSEQUENTIAL DAMAGES, WHETHER RESULTING FROM THE USE, MISUSE OR INABILITY TO USE THE PRODUCT OR FROM DEFECTS IN THE PRODUCT. SOME STATES DO NOT ALLOW THE EXCLUSION OF INCIDENTAL OR CONSEQUENTIAL DAMAGES, SO THE ABOVE LIMITATIONS MAY NOT APPLY TO YOU.

Vesper Marine retains the exclusive right to repair or replace the product or offer a full refund of the purchase price at its sole discretion. SUCH REMEDY SHALL BE YOUR SOLE AND EXCLUSIVE REMEDY.

*These warranty terms and conditions are provided as a summary and the specific terms and conditions of your warranty may vary by region. Please see www.vespermarine.com/xb for details of the warranty terms and conditions specific to your region.

Vesper Marine declares that this AIS Class B transponder is in compliance with Directive 2014/53/EU.

The full text of the EU Declaration of Conformity is available at the following internet address: www.vespermarine.com/compliance

This product is for use worldwide, including the following countries:

AT	BE	BG	CH	CY	CZ	DE	DK	EE	ES
FI	FR	GR	HU	IE	IS	IT	LT	LU	LV
MT	NO	NL	PL	PT	RO	SE	SI	SK	UK

This device is also approved for use in the United States, Canada, Australia and New Zealand.



Electronic Waste Recycling

Various regional and national regulations exist regarding the recycling of certain electronics.

Please consult your local authorities or contact Vesper Marine for recycling information.





45 Sale Street, Freemans Bay, Auckland, New Zealand
Phone +64 9 950 4848 | Email info@vespermarine.com
Fax +64 9 950 4085 | Web www.vespermarine.com
Follow us on Facebook | www.facebook.com/vespermarine

Copyright © 2016, Vesper Marine Ltd.

AIS WatchMate and WatchMate Vision are registered trademarks of Vesper Marine Ltd.
All other products are trademarks or registered trademarks of their respective owners.

Unless otherwise indicated, all documentation and operating software contained within this product or distributed with this product is copyrighted by Vesper Marine Ltd. All rights are reserved.

Portions of this product may use software licensed under open source license agreements.
Source code for the applicable software is available upon request from Vesper Marine Ltd.

XB-8000 1708

Member of:

