

# Heavy Duty Guide On Post

**Assembly Instructions**  
**Part #86103/86441 - 48" Model**  
**Part #86119/86440 - 60" Model**

**Tools Required:** 9/16" Deep Socket, 9/16" Wrench, Pliers and Phillips Head Screw Driver

Parts List		Description	Qty
Description	Qty		
34" x 1-1/2" sq. Support Tube	2	48" or 60" PVC Tube with Orange	
Upper Mounting Plate	2	Bullet Caps	2
Lower Mounting Plate	2	<b>Light Kit Models Include:</b>	
3/8" x 5" Hex Head Bolt	8	48" or 60" PVC Tube with Orange	
3/8" Hex Nyloc Nut	8	Bullet Caps and LED Lights	2
3/8" Flat Washer	16	Splice Connectors	2
		Self Tapping Screws	2

## Installing your Boat Guides: Complete Parts Assembly Diagram on Back

- Before assembling the mounting hardware, decide where and which set up you will want the Guide On's placed on your trailer.

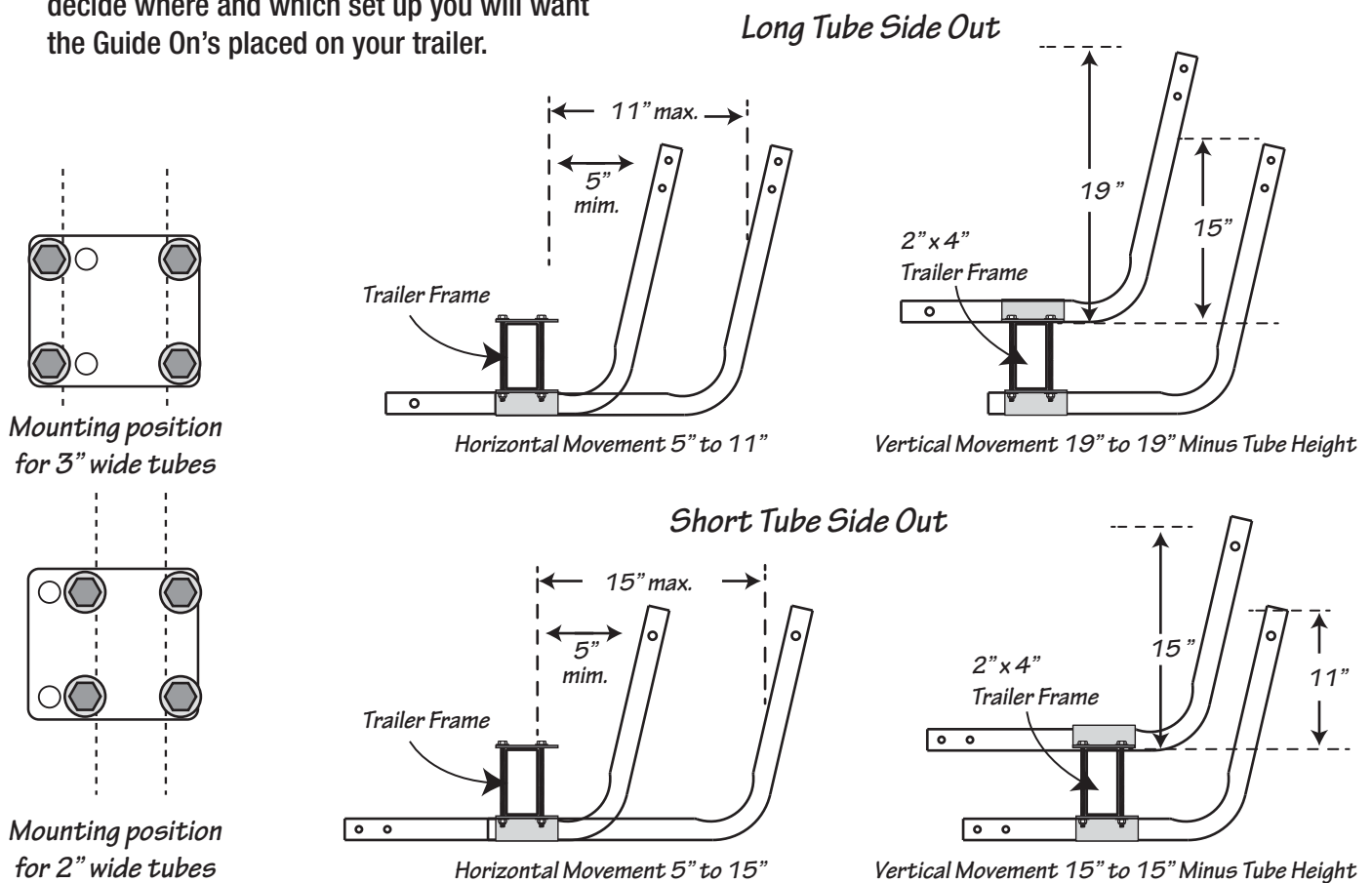

Instructions #15341 (A682 - Rev. 4/1/21)

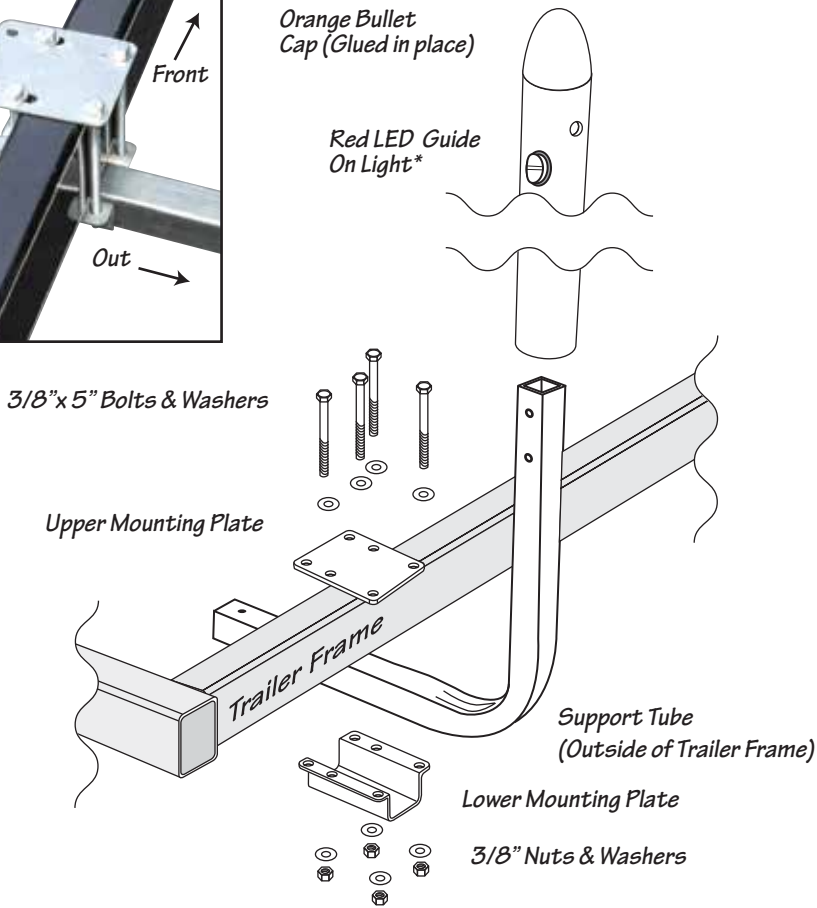
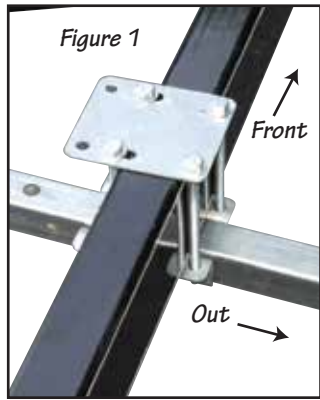

## Heavy Duty Guide On Post

### Assembly Instructions Continued

- Using 4 - 3/8" x 5" carriage bolts, 8 flat washers and 4 nyloc nuts, for each, attach the guide support mounts onto your trailer frame, as shown in figure 1. Use the holes that will keep the bolts closest to the frame tube. Finger tighten at this time. Repeat for other side.
- Slide the guide support tube into the assembly as shown in figure 2.
- Adjust the guide tubes for proper distance on each side. Tighten support mounts bolts at this time.
- Slide the PVC tubes over the metal tubes.

## \*Heavy Duty Guide On Post with Lights

### Wiring Instructions for Models 86441 & 86440

- Pull out the white and black wire from the bottom of the PVC tubes. Straighten both lines to the full length.
- Position the PVC tubes so the red light faces backward. While holding the ends of both wires slide the PVC tubes over the steel support tubes. The remaining wire should extend below the tube and steel support tube.
- Press the trailer running light wire (brown) into the open side of the splice connector. Push the black LED wire into the opposite side of the splice connector.
- Place the splice connector in the pliers and press the metal splice plate thru both wires. Close the locking tab.
- Place the self tapping screw thru the eyelet on the white grounding wire. Screw the self tapping screw into the trailer frame.
- Hook up the trailer and test your towing lights. When the trailer/tow vehicle lights are on the red LED lights should also be on.

