

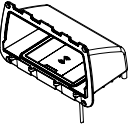

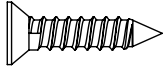



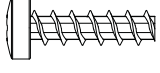

Part List	
 Pocket x1	 Countersunk screw x4
 Bezel x1	 Pan head screw x4

Tools Required		
 Jig Saw	 Pozi screwdriver	 Sealant
 Hole saw Ø20mm (0.79")	 Drill bit (see table)	<b>Optional drainage</b>  Ø5mm (0.2") Drill Bit  Drain tube Ø8mm (5/16")

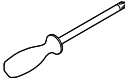
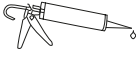
Technical	
IP Waterproof Rating	IPX6 Front and back
Input voltage	10-30V DC (12/24V System)
Input current max	2A
Output power max	15W (9V 1.25A)
Standby power max	<1.2W
Certification	CE, UKCA, FCC, ROHS, C-Tick, UN ECE R10, E24, PSE Certified

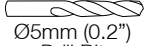

READ THE IMPORTANT SAFETY INFORMATION LEAFLET BEFORE INSTALLING.

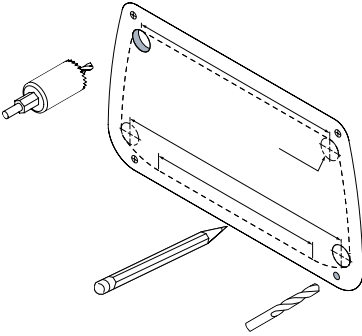

①

- Check installation size
- Mark the cutting boundary
- Use template to
  - Drill 4x pilot holes (see table)
  - Hole saw 4x 15mm (0.59")

---

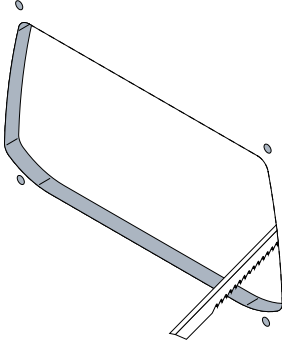

②

- Jig saw inside of the cutting boundary. DO NOT exceed the boundary area.

---

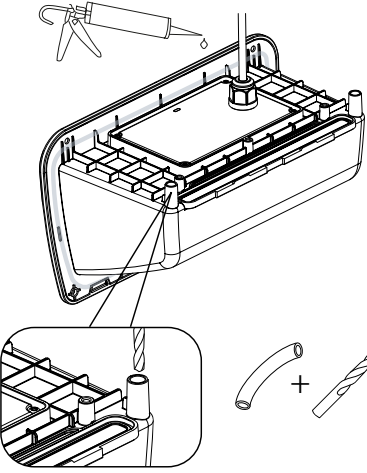

③

- Apply silicone sealant generously around flange, ensure good coverage around perimeter.

(Optional - Tools and parts not included).

- Install drainage on product.
  - Drain holes: Ø5mm (0.2") drill bit required.
  - Drain pipe: ID Ø8mm (5/16") required.

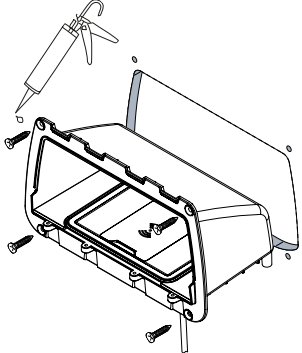

④

- Secure pocket in place using 4x countersunk fixings.
- Apply silicone sealant to fixings holes.

---

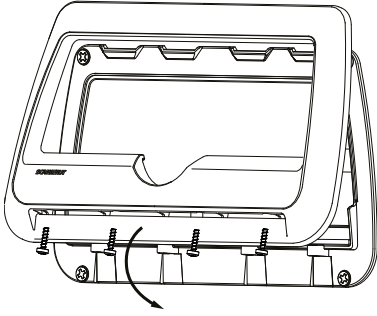

⑤

- Attach front bezel.
- Secure in place using 4x pan head fixings.

---

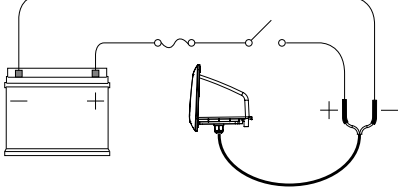

⑥

- Connect wires or connectors to 12/24V supply, ensuring a waterproof connection.
- Fuse according to input voltage and current.

Note: The electrical schematic is to illustrate how the product should be connected to a 12V DC or 24V DC battery/power supply.

**UK & International**  
+44 (0)1392531280  
sales@scanstrut.com

For further installation and warranty information please visit:  
www.scanstrut.com

**USA**  
+1 860 308 1416  
usasales@scanstrut.com



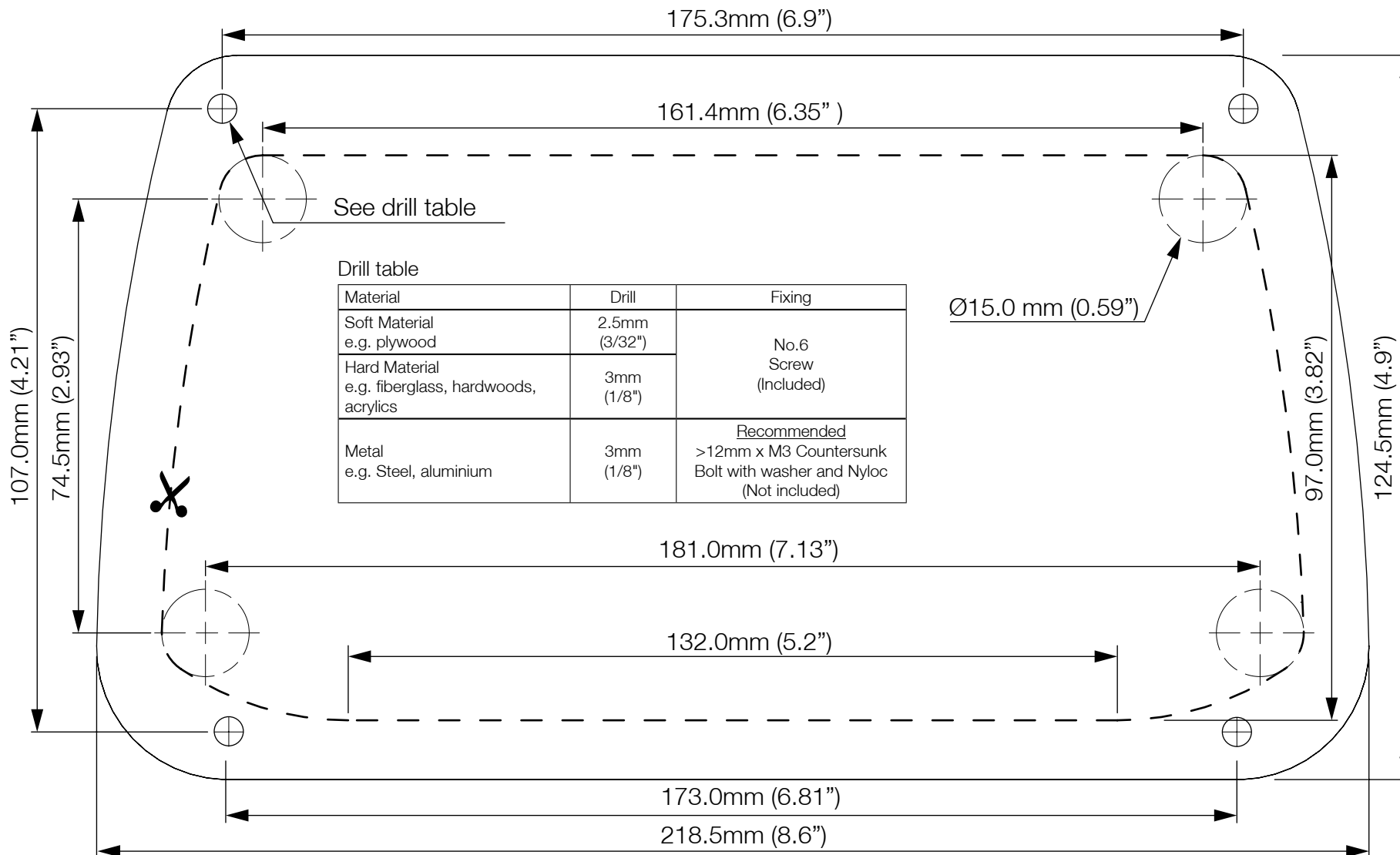

Print document 1:1  
 scale for correct  
 cutting template  
 size.

Paper Size A4

LED Charging indicator

○ White LED Constant: ON Charge

● Red LED Constant: Standby (power ON)



Red LED Flashing:

Foreign object detection: metallic object placed on top that is not Qi compatible.

OR



Thermal cutout: The internal temperature is too high/ low. Wait for product to return to operating temperature.



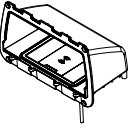
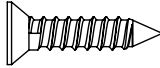

UK & International  
 +44 (0)1392531280  
 sales@scanstrut.com

For further installation  
 and warranty information  
 please visit:  
 www.scanstrut.com

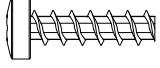
USA  
 +1 860 308 1416  
 usasales@scanstrut.com

**SCANSTRUT.**

Part List	
 Pocket x1	 Countersunk screw x4
 Bezel x1	 Pan head screw x4

Tools Required	
 Jig Saw	 Pozi screwdriver
 Hole saw Ø20mm (0.79")	 Drill bit (see table)

Technical	
IP Waterproof Rating	IPX5 Front and back
Input voltage	10-30V DC (12/24V System)
Input current max	2A
Output power max	15W (9V 1.25A)
Standby power max	<1.2W
Certification	CE, UKCA, FCC, ROHS, C-Tick, UN ECE R10, E24, PSE Certified
RGB LED	
Input voltage	9-15V DC
Input current max	0.2A
Standby power draw	<0.0W



READ THE IMPORTANT SAFETY INFORMATION LEAFLET BEFORE INSTALLING.

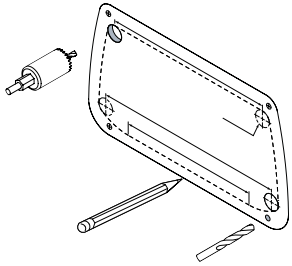

**①**

- Check installation size
- Mark the cutting boundary
- Use template to
  - Drill 4x pilot holes (see table)
  - Hole saw 4x 15mm (0.59")

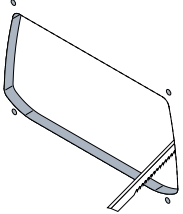

**②**

- Jig saw inside of the cutting boundary. DO NOT exceed the boundary area.

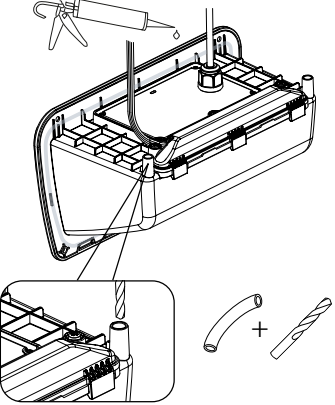

**③**

- Apply silicone sealant generously around flange, ensure good coverage around perimeter. (Optional - Tools and parts not included).
- Install drainage on product.
  - Drain holes: Ø5mm (0.2") drill bit required.
  - Drain pipe: ID Ø8mm (5/16") required.

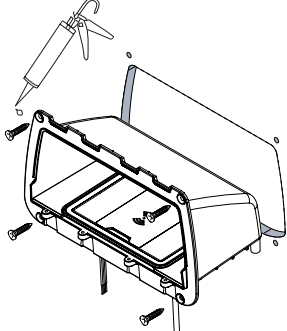

**④**

- Secure pocket in place using 4x countersunk fixings.
- Apply silicone sealant to fixings holes.

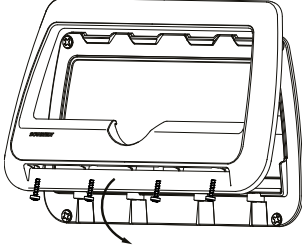

**⑤**

- Attach front bezel.
- Secure in place using 4x pan head fixings.

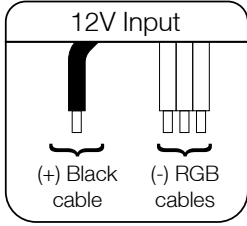

**6a)**

- For a single light color, make a (+) positive connection to the black cable.
- Make a (-) negative connection to any of the Red, Green or Blue cables.

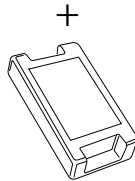

**6b) (Optional)**

- Connect all three RGB cables to an RGB Controller for multicolor lighting control.

Optional LED driver (not included)

Caution: The RGB wiring should be used on a 12V system only. See technical information for guidance.

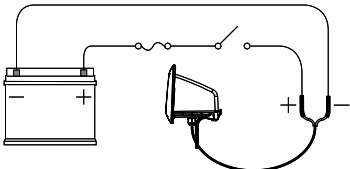

**⑦**

- Connect wires or connectors to 12/24V supply, ensuring a waterproof connection.
- Fuse according to input voltage and current.

Note: The electrical schematic is to illustrate how the product should be connected to a 12V DC or 24V DC battery/power supply.

UK & International +44 (0)1392531280 sales@scanstrut.com  
 For further installation and warranty information please visit: www.scanstrut.com  
 USA +1 860 308 1416 usasales@scanstrut.com



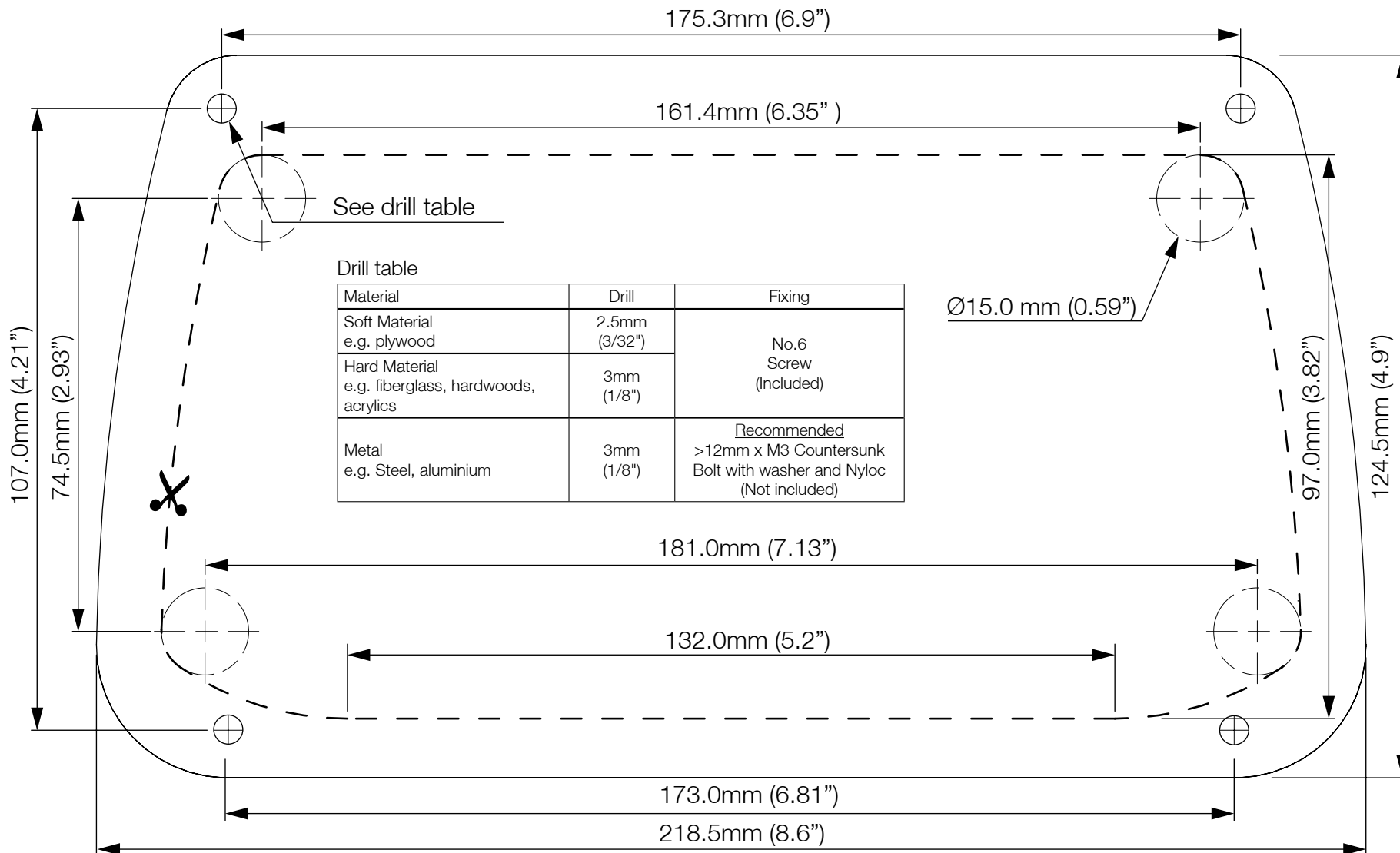

Print document 1:1  
scale for correct  
cutting template  
size.

Paper Size A4

LED Charging indicator

○ White LED Constant: ON Charge

● Red LED Constant: Standby (power ON)



Red LED Flashing:

Foreign object detection: metallic object placed on top that is not Qi compatible.

OR

Thermal cutout: The internal temperature is too high/ low. Wait for product to return to operating temperature.

UK & International  
+44 (0)1392531280  
sales@scanstrut.com

For further installation  
and warranty information  
please visit:  
www.scanstrut.com

USA  
+1 860 308 1416  
usasales@scanstrut.com

**SCANSTRUT.**