

## Furler System Information

The furler you have purchased is designed for top-down furling of sails with a “soft” luff and full mid-section, such as coded asymmetrics, reachers and gennakers.

These sails are generally for sailing at true wind angles of greater than 90°. The top-down furler is designed to have the tack of the sail attached to the “floating” swivel collar at the base of the fork on the furler, and the head of the sail attached to the top swivel. Furling begins at the top of the sail and continues progressively from the head down to the tack.

The sail must be either completely unfurled or furled – the furler cannot be used with a partially furled sail. You will require a synthetic luff cable (torsion line) with a thimble at each end, connected between the fork of the furler at the bottom and the swivel at the top. We recommend you discuss options with your sail maker for torsion line type, diameter and length, to suit your requirements. Effective top-down furling relies on the size and quality of the torsion rope - use the largest size that will fit in the thimble.

Ronstan provides a range of accessories to suit this furler which can be found at the end of this manual.

### FURLER SETUP – STRAIGHT LUFF SAILS:

- 1 Torsion Rope
- 2 Continuous Furling Line
- 3 Top Swivel
- 4 Thimble
- 5 Furler
- 6 Shackle, Snap Shackle or 2:1 Fairlead

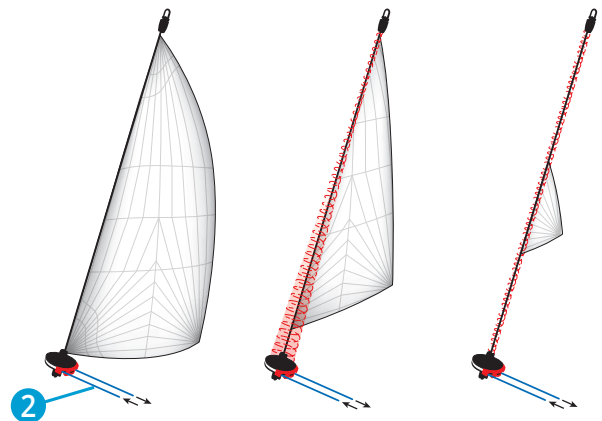
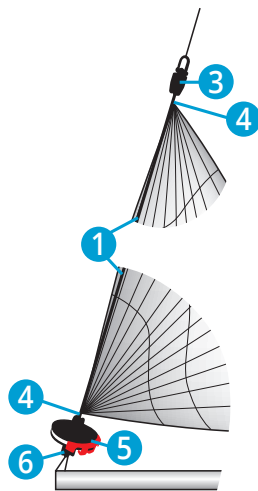

*As furling drum rotates, sail furls around the luff cable along its entire length.*

### FURLER SETUP – SOFT LUFF SAILS:

- 1 Torsion Rope
- 2 Continuous Furling Line
- 3 Top Swivel
- 4 Thimble
- 5 Furler
- 6 Top Down Swivel Collar (Tack Attachment)
- 7 Shackle, Snap Shackle or 2:1 Fairlead

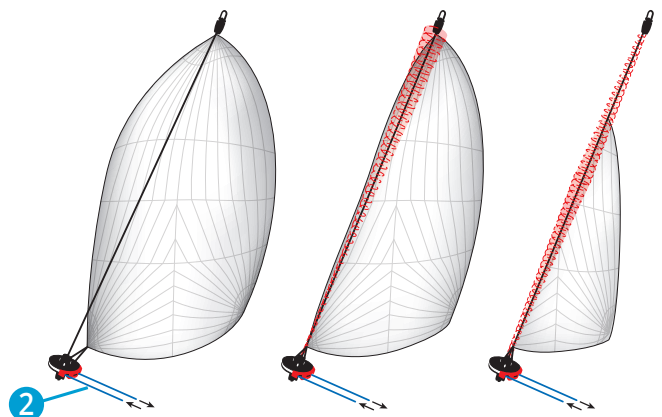
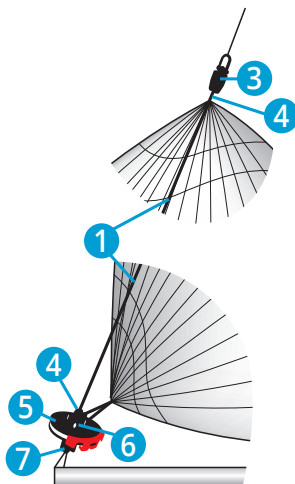

*As furling drum rotates, the tack remains stationary on the “floating” collar. The torsion rope turns the top swivel, furling the sail from the top down.*

## TACK ATTACHMENT

The tack of the sail is attached to the floating collar by means of lashing through the three holes as shown. This ensures an even load distribution on the collar and therefore effective free swivelling.

The offset nature of the three lugs and holes helps to keep the tack clear of the rotating torsion rope during furling.

**TIP:** If the tack of the sail is very stiff, it may be prone to catching on the torsion line whilst furling. To avoid this, attach an additional loose line to the tack of the sail. Pulling on this line while furling will keep the tack clear of the torsion rope.

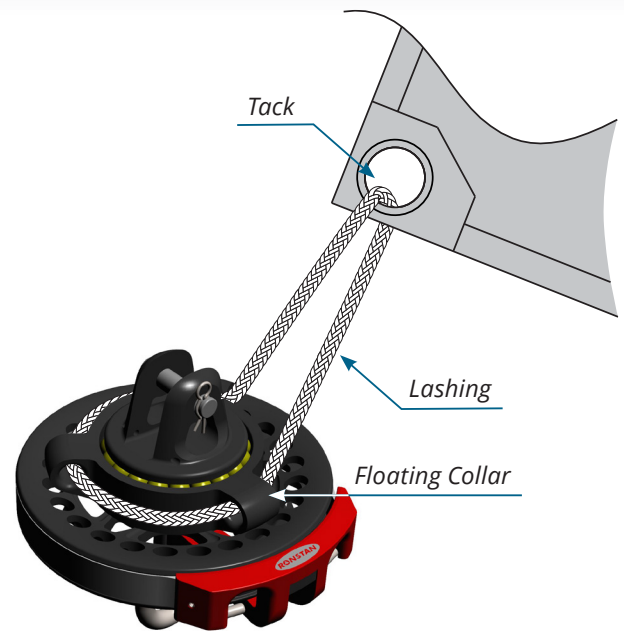

## CONTINUOUS FURLING LINE INSTALLATION & REMOVAL

The furling line can be easily loaded and removed from the furler, for installations where the furling line is permanently routed back to the cockpit through blocks or fairleads.

The Series 80 furler is optimised for use with 8mm (5/16") rope. Rotate the drum to align the slot in the bottom plate of the drum with the guide opening.

- 1 Push the rope through the guide opening and deep in to the slot until the rope is in the hole.
- 2 Rotate the drum all the way around until the slot lines up with the guide opening on the other side of the guide.
- 3 Pull the rope out through the guide opening.

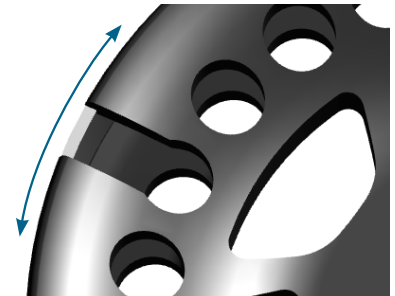

Drum slot

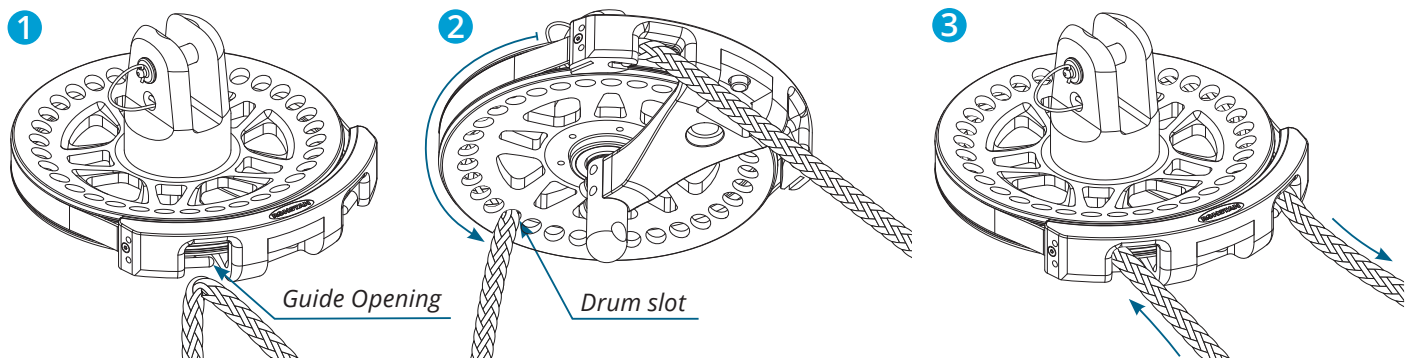

## FURLING LINE ALIGNMENT

It is important that the furling line is correctly aligned with the guide as shown below. Blocks or fairleads should be used to guide the line where required.

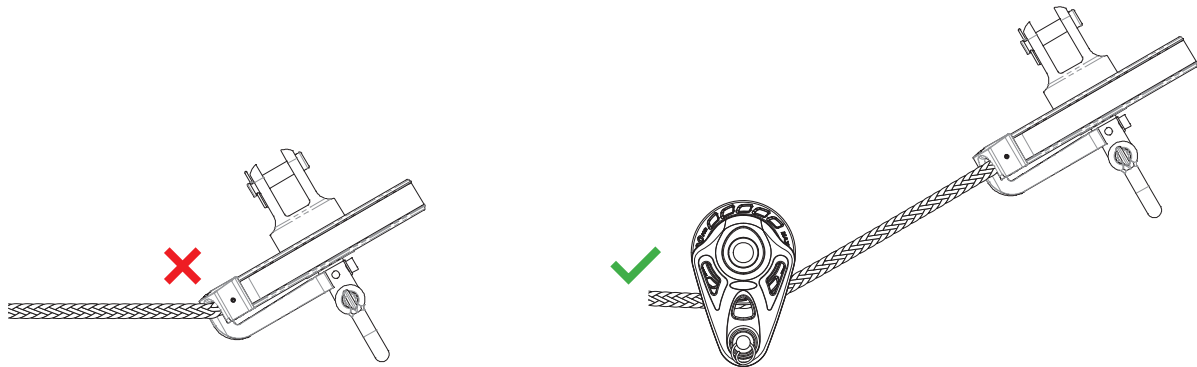

The furling line can be cleated to keep the sail from unfurling.

## GUIDE ARM ALIGNMENT

The guide arm can be positioned in-line or at 90 degrees to correctly align the furler mount with the deck or bowsprit attachment.

To change the orientation of the guide arm:

- 1 Remove the screw located in the guide arm underneath the drum.
- 2 Rotate the guide arm and PTFE strip 90° until the hole in the guide arm lines up with the alternate hole in the shaft.
- 3 Re-connect the guide arm to the shaft using the same screw.

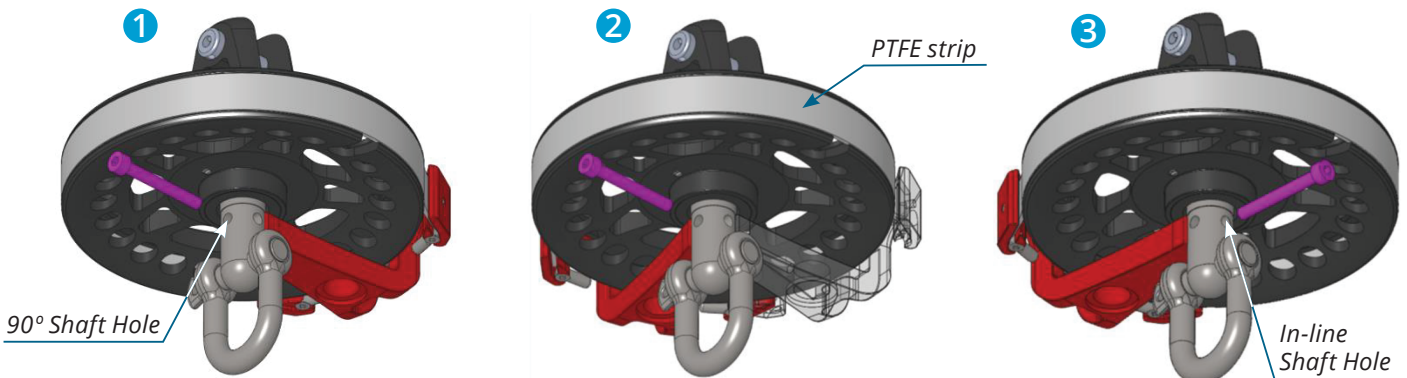

## ACCESSORIES

### RS208010 – Top Swivel

The top half of the continuous line furling system, the top swivel is matched to furler load rating and the fork is designed for use with our dedicated torsion line thimble. It features a maintenance free, factory sealed bearing, retained clevis pin and snag-free low profile shackle pin head.

### RS208020 – Snap-Shackle

Simply replace the shackle on the furler or top swivel with the snap-shackle adaptor for quick attachment of the furler to your bow fitting or the top swivel to your halyard.

### RS208030 – 2:1 Fairlead

Use in place of the shackle on the furler to provide a 2:1 purchase on the furler attachment. The tack line is dead ended at the deck or end of the bowsprit, runs up around the 2:1 fairlead, back down to a block, and back along the deck to a rope clutch.

This configuration is a popular way of adjusting tension in the torsion rope, and hence the luff of the sail.



*Typical 2:1 setup*

### RS208040 – Thimble

Used to terminate the torsion rope at both ends by wrapping the torsion rope around the thimble and then either stitching it to itself, or splicing it. The thimble also has an additional hole suited to lashing the tack of the sail to it. Lashing the sail to the thimble and not to the furler allows the torsion line and sail to be easily removed from the furler and top swivel as required.

### RS208050 – Shackle

Replacement shackles can be ordered to suit both the top swivel and the furler.

### RS208080 – Top Swivel Lashing Pin

Use in place of the clevis pin on the top swivel to provide a more positive drive to the head of the sail. This helps to ensure a tight furl at the head.

The head of the sail is lashed to the cotton reels on the ends of the pin while the torsion rope and thimble are attached to the centre section of the pin.

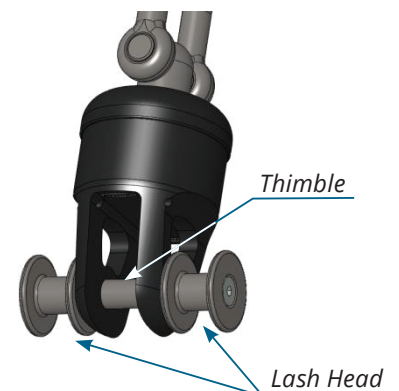

## MAINTENANCE

- Rinse regularly with fresh water to remove salt.
- Apply Ronstan RF3000 Sailfast™ (or a similar silicon based lubricant) over the body and components to enhance performance and prolong service life. (Do not use petro-chemical lubricants).
- Periodically remove fasteners and re-apply Tef-Gel® (TG-10) to prevent corrosion.
- Factory sealed bearings are maintenance free. Bearing and seal replacement can be arranged through your local Ronstan re-seller.
- Furlers have a three year warranty – refer to [www.ronstan.com](http://www.ronstan.com) for terms and conditions.

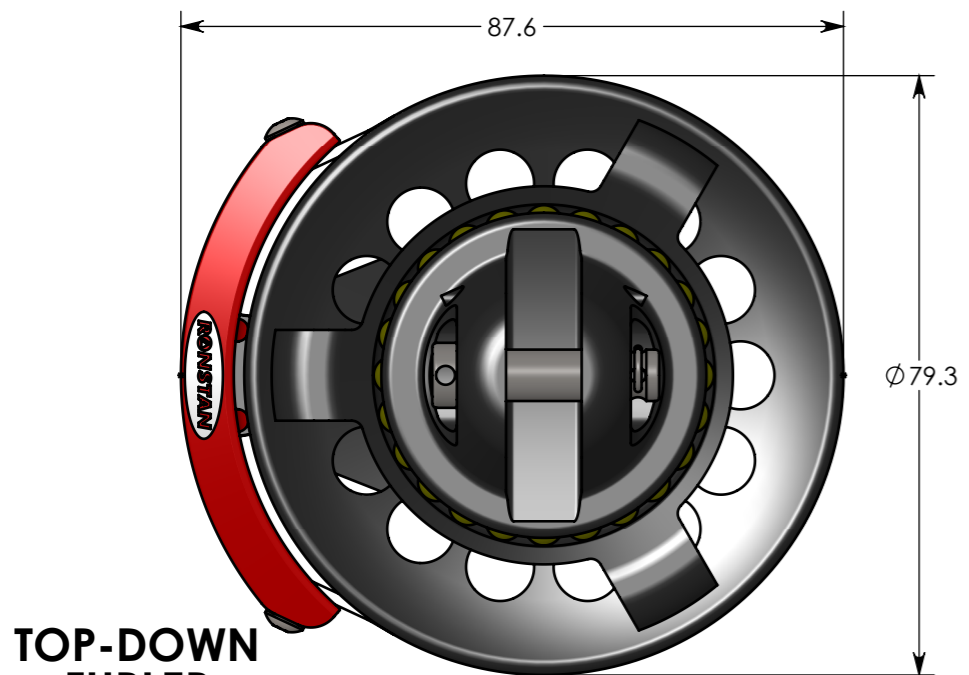

**TOP-DOWN FURLER RS208100**

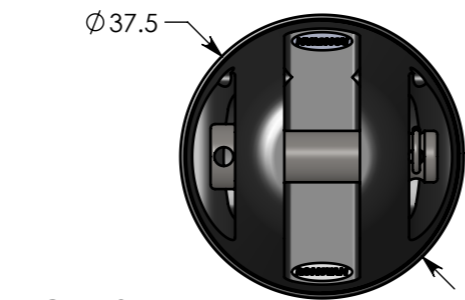

**TOP SWIVEL RS208010**

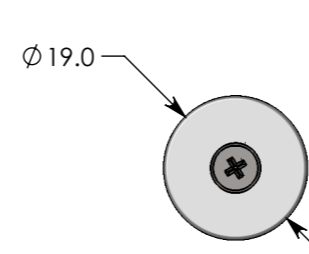

**TOP SWIVEL LASHING PIN RS208080**

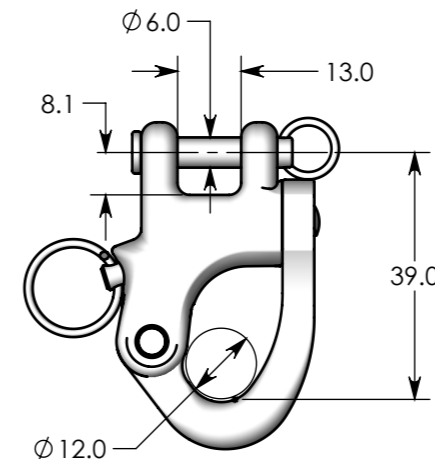
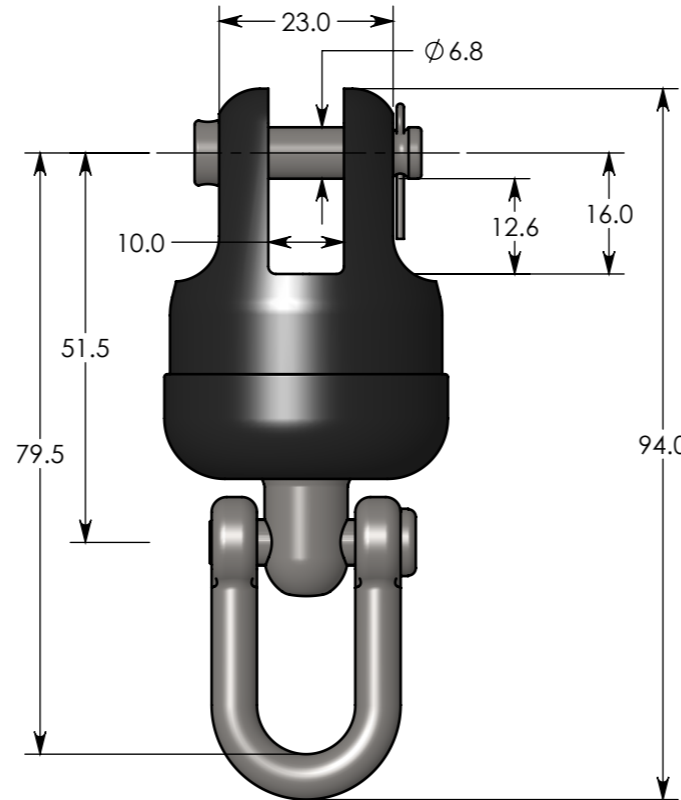
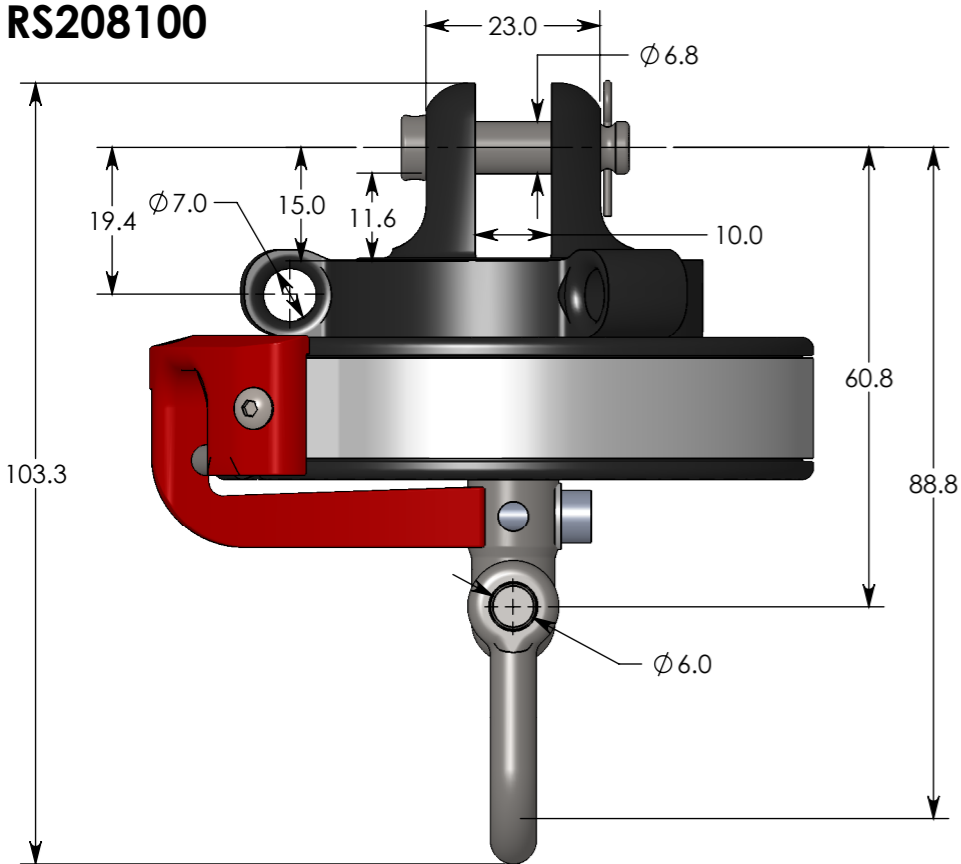
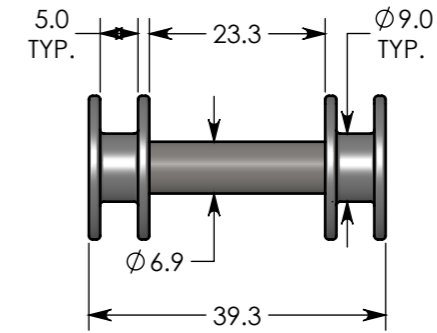

**SNAP-SHACKLE ADAPTOR RS208020**

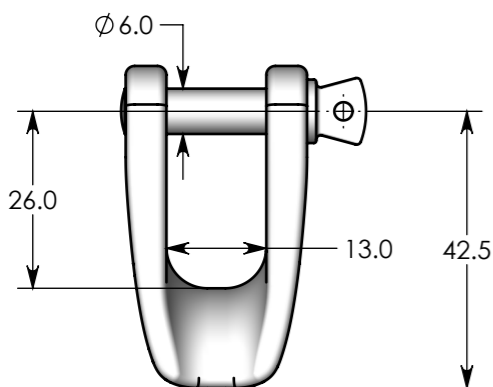

**2:1 FAIRLEAD RS208030**

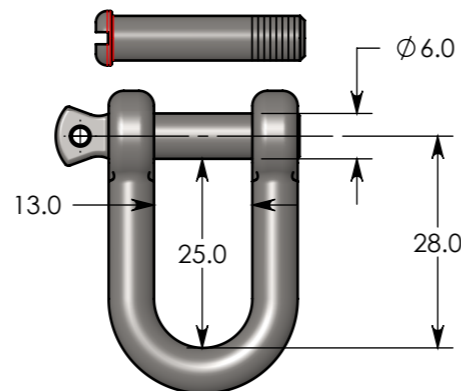

**SHACKLE RS208050**

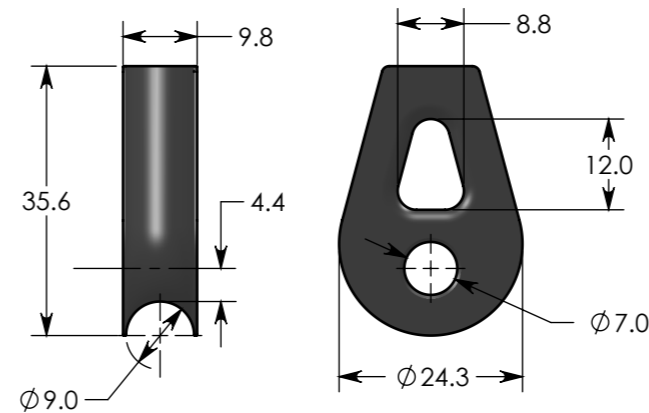

**THIMBLE RS208040**

**SPECIFICATIONS: RS208100 + RS208010 S80 TOP-DOWN FURLER & TOP SWIVEL**

**RS208100 - TOP-DOWN FURLER & SHACKLE**  
 MWL = 950kg (2090lb)  
 BL = 1900kg (4190lb)  
 WEIGHT \* = 241g (8.5oz)  
 FURLER LINE Ø = 8mm (5/16")  
 SHACKLE = 6mm

**RS208010 - TOP SWIVEL & SHACKLE WITH FLUSH PIN**  
 MWL = 950kg (2090lb)  
 BL = 1900kg (4190lb)  
 WEIGHT \* = 111g (3.9oz)  
 SHACKLE = 6mm

\*Weight doesn't include Shackle

**ACCESSORIES:**

**RS208020 - SNAP SHACKLE ADAPTOR**  
 MWL = 960kg (2120lb)  
 BL = 2000kg (4410lb)  
 WEIGHT = 54g (1.9oz)

**RS208030 - 2:1 FAIRLEAD**  
 MWL = 1040kg (2290lb)  
 BL = 2300kg (5070lb)  
 WEIGHT = 44g (1.6oz)

**RS208040 - LUFF LINE THIMBLE**  
 MATERIAL = AL6061, ANODISED  
 WEIGHT = 8g (0.3oz)

**RS208050 - SHACKLE, 6mm (PLUS FLUSH PIN)**  
 BL = 1950kg (4300lb)  
 WEIGHT = 26g (0.9oz)

**RS208080 - TOP SWIVEL LASHING PIN, 7mm**  
 MWL = 950kg (2090lb)  
 BL = 1900kg (4190lb)  
 WEIGHT = 29g (1.0oz)

THE DOCUMENT & THE DESIGN ON IT IS THE EXCLUSIVE PROPERTY OF RONSTAN INTERNATIONAL PTY. LTD. & IS THE SUBJECT OF COPYRIGHT.



DATE: 05/12/16  
 ALL DIMS IN MM  
 DO NOT SCALE

www.ronstan.com