

## Furler System Information

The furler you have purchased is designed for the furling of sails with a “straight” luff, such as code zero sails, screechers or staysails. These sails are generally for sailing at true wind angles less than 90°. The furler is designed to have the tack of the sail attached to the furler and the head of the sail attached to the top swivel. This will provide furling along the whole luff of the sail.

The sail must be either completely unfurled or completely furled – the furler cannot be used with a partially furled sail.

You will require a synthetic luff cable (torsion line) with a thimble at each end, connected between the fork of the furler at the bottom and the swivel at the top. We recommend you discuss options with your sail maker for torsion line type, diameter and length, to suit your requirements.

Ronstan provides a range of accessories to suit this furler which can be found at the end of this manual.

### FURLER SETUP – STRAIGHT LUFF SAILS:

- 1 Torsion rope
- 2 Continuous Furling Line
- 3 Top Swivel
- 4 Thimble
- 5 Furler
- 6 Shackle, Snap Shackle or 2:1 Fairlead

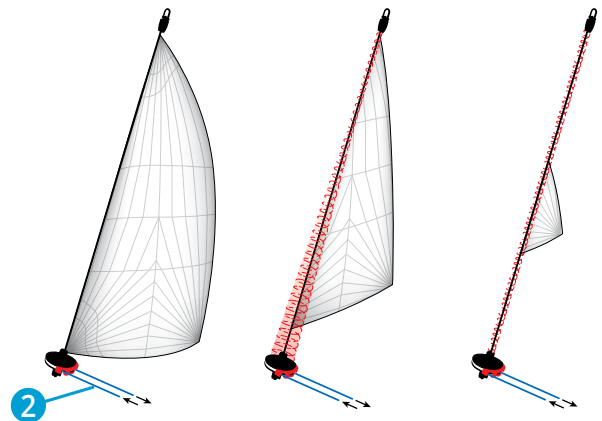
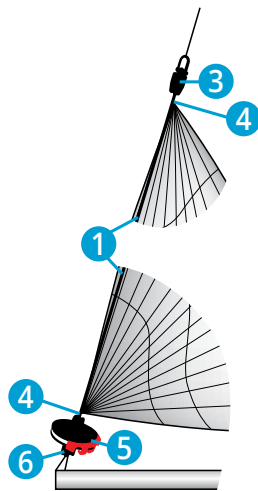

*As furling drum rotates, sail furls around the luff cable along its entire length.*

## FURLING LINE ALIGNMENT

It is important that the furling line is correctly aligned with the guide as shown below. Blocks or fairleads should be used to guide the line where required.

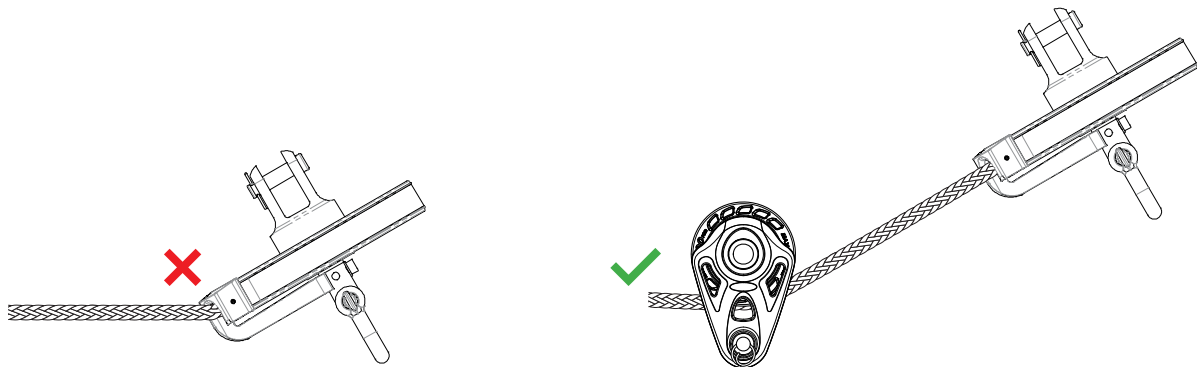

The furling line can be cleated to keep the sail from unfurling.

## CONTINUOUS FURLING LINE INSTALLATION & REMOVAL

The furling line can be easily loaded and removed from the furler, for installations where the furling line is permanently routed back to the cockpit through blocks or fairleads.

The Series 120 furler is optimised for use with 8mm (5/16") rope. Rotate the drum to align the slot in the bottom plate of the drum with the guide opening.

- 1 Push the rope through the guide opening and deep in to the slot until the rope is in the hole.
- 2 Rotate the drum all the way around until the slot lines up with the guide opening on the other side of the guide.
- 3 Pull the rope out through the guide opening.

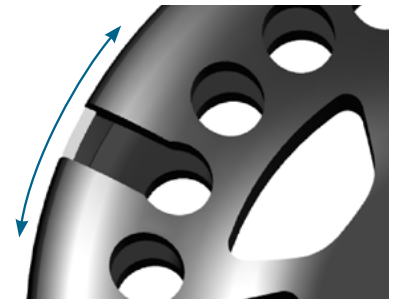

Drum slot

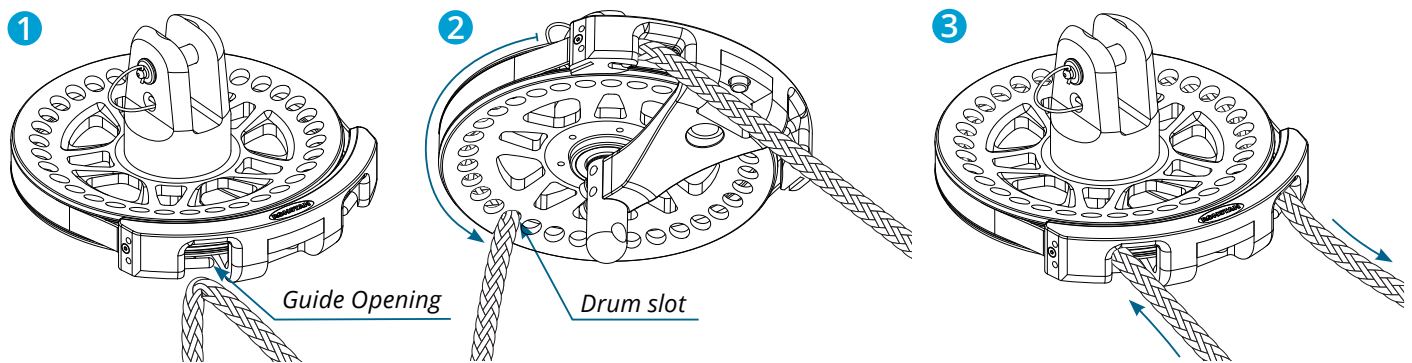

## GUIDE ARM ALIGNMENT

The guide arm can be positioned in-line or at 90 degrees to correctly align the furler mount with the deck or bowsprit attachment.

To change the orientation of the guide arm:

- 1 Remove the screw located in the guide arm underneath the drum.
- 2 Rotate the guide arm and PTFE strip 90° until the hole in the guide arm lines up with the alternate hole in the shaft.
- 3 Re-connect the guide arm to the shaft using the same screw.

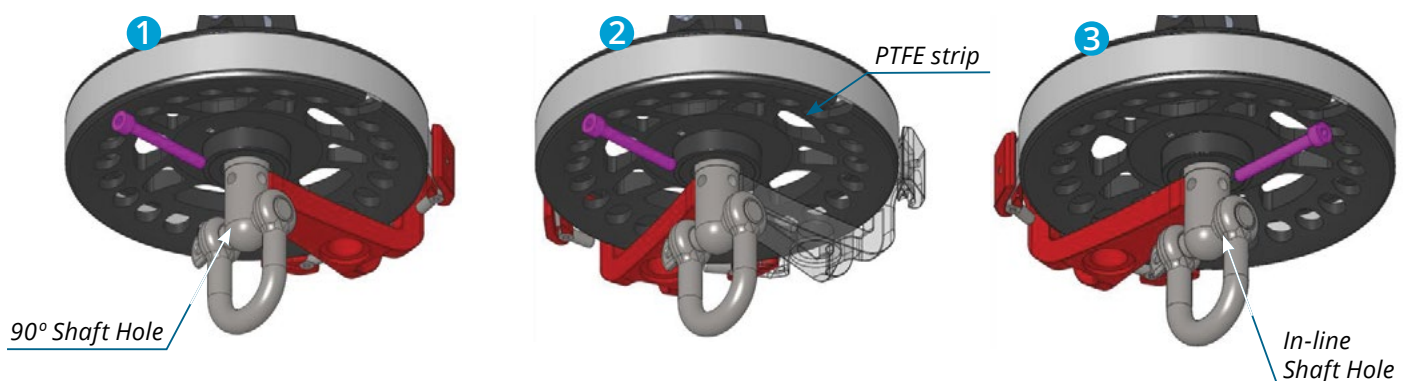

90° Shaft Hole

PTFE strip

In-line Shaft Hole

## ACCESSORIES

### RS212010 – Top Swivel

The top half of the continuous line furling system, the top swivel is matched to furler load rating and the fork is designed for use with our dedicated torsion line thimble. It features a maintenance free, factory sealed bearing, retained clevis pin and snag-free low profile shackle pin head.

### RS212020 – Snap-Shackle

Simply replace the shackle on the furler or top swivel with the snap-shackle adaptor for quick attachment of the furler to your bow fitting or the top swivel to your halyard.

### RS212030 – 2:1 Fairlead

Use in place of the shackle on the furler to provide a 2:1 purchase on the furler attachment. The tack line is dead ended at the deck or end of the bowsprit, runs up around the 2:1 fairlead, back down to a block, and back along the deck to a rope clutch.

This configuration is a popular way of adjusting tension in the torsion rope, and hence the luff of the sail.



*Typical 2:1 setup*

### RS212040 – Thimble

Used to terminate the torsion rope at both ends by wrapping the torsion rope around the thimble and then either stitching it to itself, or splicing it. The thimble also has an additional hole suited to lashing the tack of the sail to it. Lashing the sail to the thimble and not to the furler allows the torsion line and sail to be easily removed from the furler and top swivel as required.

### RS212050 – HR Shackle

Replacement shackles can be ordered to suit both the top swivel and the furler.

### RS212070 – Rotation Stop

This is designed to be engaged once the sail is fully furled to avoid unintentional unfurling if the furling line is un-cleated. Useful if the furled sail is to be left in position for a period of time or lowered to be put in its bag.

The stop assembly is screwed in to the threaded hole in the guide arm. It incorporates a spring-loaded plunger pin which, once engaged, sits in one of the through-holes in the drum to prevent rotation.

The rotation stop can either be operated manually at the furler unit, or remotely using a trigger line attached to the spring pin and led back to a cleat. This will allow remote locking or unlocking of the furler.

The furler will experience some movement due to pitching of the boat, so attach a short length of shock cord to the trigger line to maintain tension and keep the plunger pin disengaged.

The rotation stop is designed to fail if a high load is applied to the furling line, in order to avoid damage to the furler. A failed stop can easily be replaced with a new one.

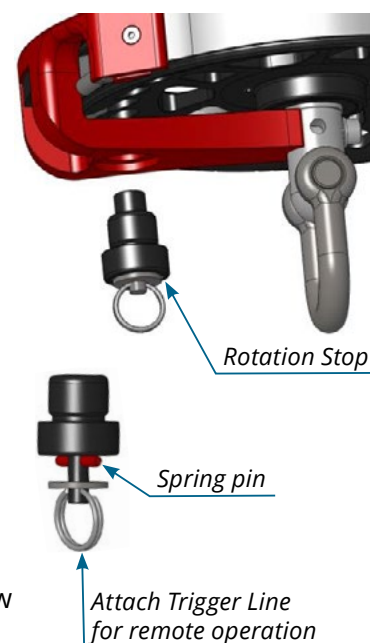

## MAINTENANCE

- Rinse regularly with fresh water to remove salt.
- Apply Ronstan RF3000 Sailfast™ (or a similar silicon based lubricant) over the body and components to enhance performance and prolong service life. (Do not use petro-chemical lubricants).
- Periodically remove fasteners and re-apply Tef-Gel® (TG-10) to prevent corrosion.
- Factory sealed bearings are maintenance free. Bearing and seal replacement can be arranged through your local Ronstan re-seller.
- Furlers have a three year warranty – refer to [www.ronstan.com](http://www.ronstan.com) for terms and conditions.

*Tef-Gel® is a registered trademark of Ultra Safety Systems Inc.  
Sailfast™ is a trademark of Ronstan International Pty. Ltd.*

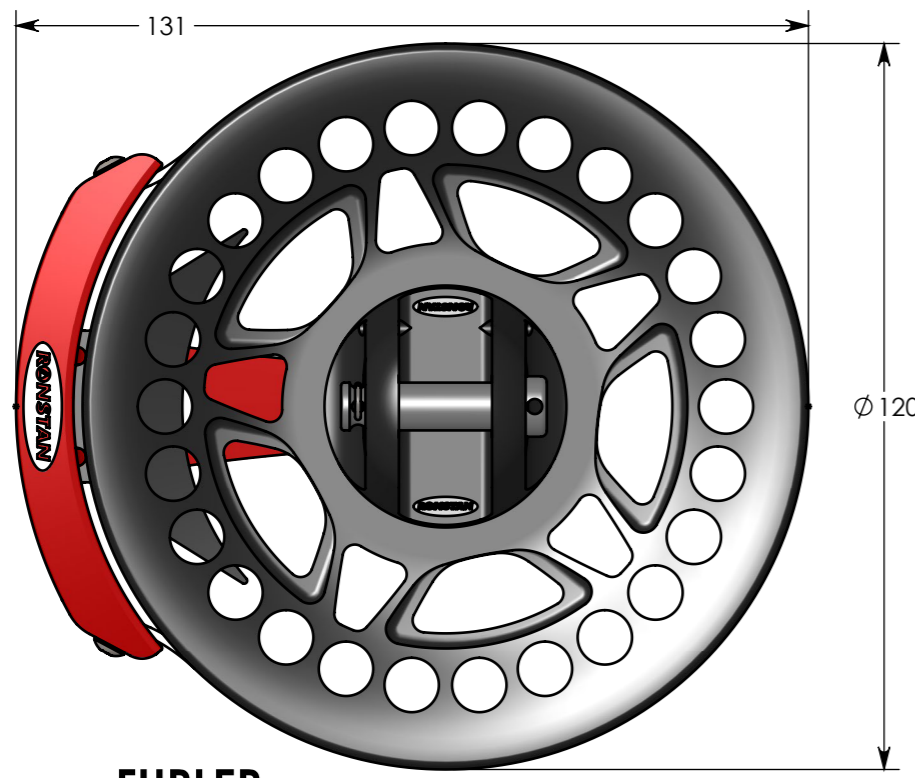

**FURLER  
RS212000**

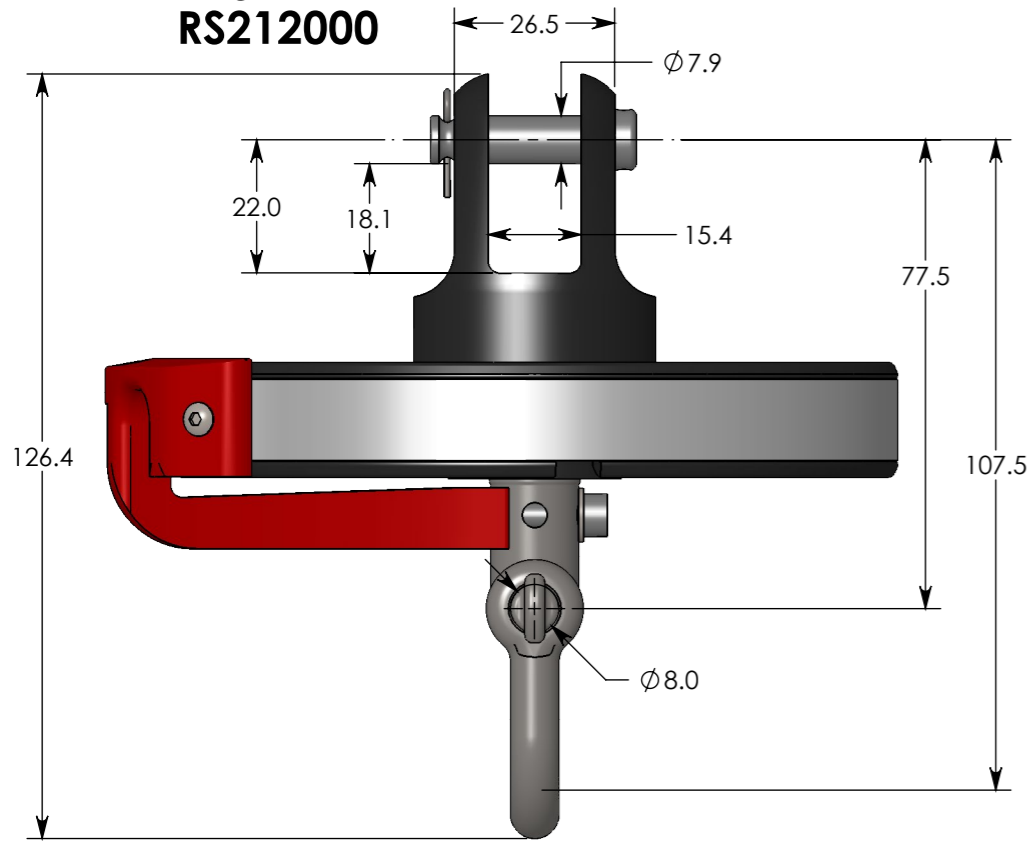

**TOP SWIVEL  
RS212010**

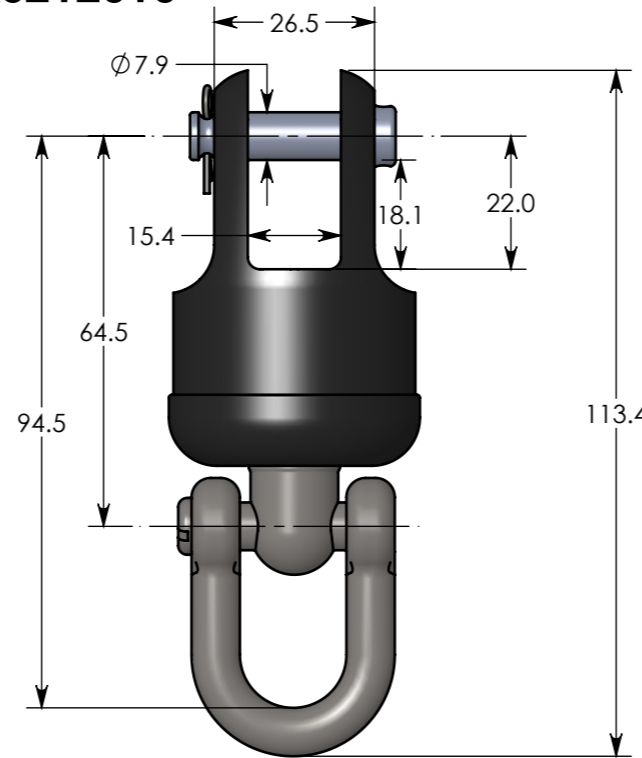

**TOP SWIVEL  
LASHING PIN  
RS212080**

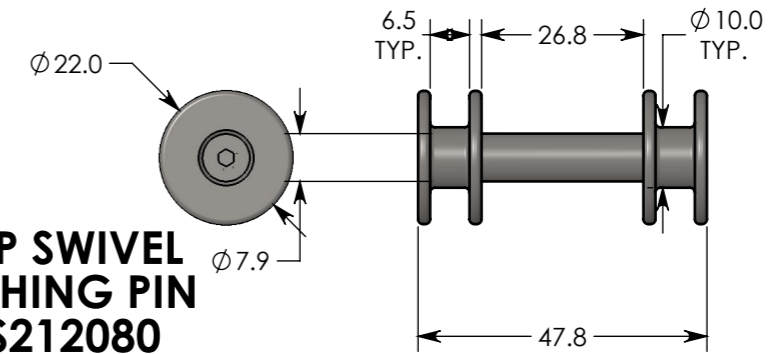

**ROTATION STOP  
RS212070**

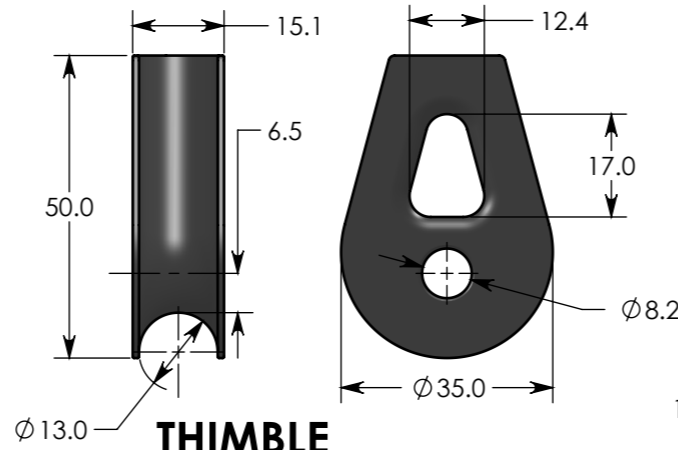

**THIMBLE  
RS212040**

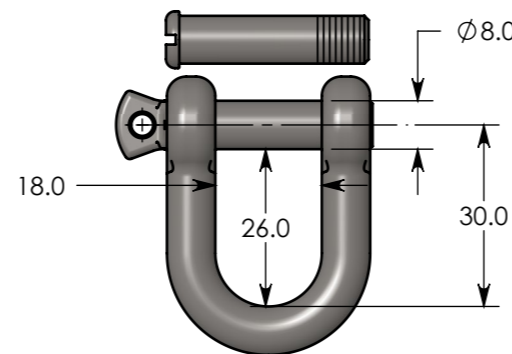

**HR SHACKLE  
RS212050**

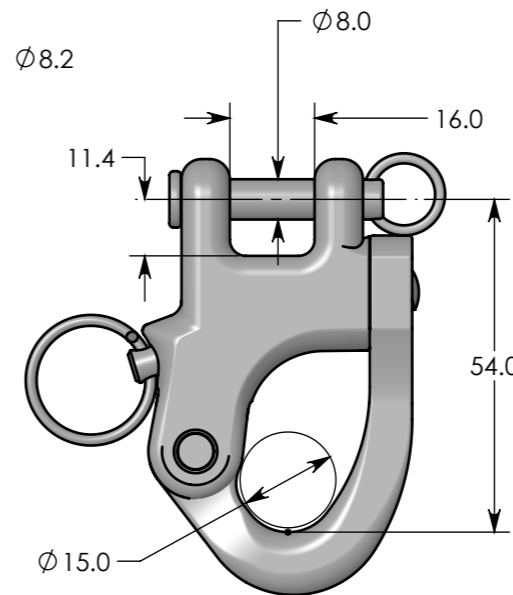

**SNAP-SHACKLE  
ADAPTOR  
RS212020**

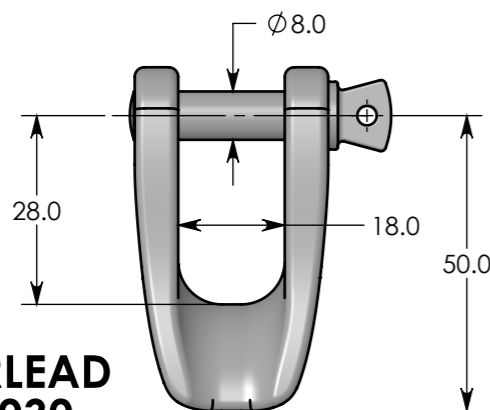

**2:1 FAIRLEAD  
RS212030**

**SPECIFICATIONS: RS212000 + RS212010  
S120 FURLER & TOP SWIVEL**

**RS212000 - FURLER & SHACKLE**  
 MWL = 1800kg (3970lb)  
 BL = 3600kg (7940lb)  
 WEIGHT \* = 383g (13.5oz)  
 FURLER LINE Ø = 8mm (5/16")  
 SHACKLE = 8mm HR

**RS212010 - TOP SWIVEL & SHACKLE WITH FLUSH PIN**  
 MWL = 1800kg (3970lb)  
 BL = 3600kg (7940lb)  
 WEIGHT \* = 162g (5.7oz)  
 SHACKLE = 8mm HR

\*Weight doesn't include Shackle

**ACCESSORIES:**

**RS212020 - SNAP SHACKLE ADAPTOR**  
 MWL = 1280kg (2820lb)  
 BL = 3850kg (8490lb)  
 WEIGHT = 130g (4.6oz)

**RS212030 - 2:1 FAIRLEAD**  
 MWL = 1760kg (3880lb)  
 BL = 4100kg (9040lb)  
 WEIGHT = 96g (3.4oz)

**RS212040 - THIMBLE**  
 MATERIAL = AL6061, ANODISED  
 WEIGHT = 23g (0.8oz)

**RS212050 - HR SHACKLE, 8mm (PLUS FLUSH PIN)**  
 BL = 4400kg (9700lb)  
 WEIGHT = 55g (1.9oz)

**RS212070 - FURLER ROTATION STOP**  
 WEIGHT = 10g (0.3oz)

**RS212080 - TOP SWIVEL LASHING PIN, 8mm**  
 MWL = 1800kg (3970lb)  
 BL = 3600kg (7940lb)  
 WEIGHT = 48g (1.7oz)

THE DOCUMENT & THE DESIGN ON IT IS THE EXCLUSIVE PROPERTY OF RONSTAN INTERNATIONAL PTY. LTD. & IS THE SUBJECT OF COPYRIGHT.



DATE 12/07/13  
 ALL DIMS IN MM  
 DO NOT SCALE

www.ronstan.com

TITLE Series 120 Furler Spec Sheet