

Raymarine



AIS5000

Installation and operation instructions

English
Date: 04-2022
Document number: 81383-8
© 2022 Raymarine UK Limited

List of abbreviations

AIS	Automatic Identification System
AIS SART	AIS Search and Rescue Transmitter
AP	Access Point (Relating to WiFi behaviour)
AtoN	AIS Aid to Navigation
CD	Compact Disc
CE	European Declaration of Conformity
COG	Course Over Ground
COM	Common (electrical)
CPA	Closest Point of Approach
CS	Carrier Sense
DC	Direct Current
Dec	Decimal
DGNSS	Differential GNSS
DHCP	Dynamic Host Configuration Protocol
DOP	Dilution of Precision
DSC	Digital Selective Calling
DTM	Datum
ECDIS	Electronic Chart Display and Information System
ENI	Unique European Vessel Identification Number
EPFS	Electronic Position Fixing System
EPIRB	Emergency Position Indicating Radio Beacon
ERI	Electronic Reporting International
ETA	Estimated Time of Arrival

List of abbreviations

EXT	External
FCC	Federal Communications Committee
GBS	GNSS satellite fault detection message
GFA	GNSS fix accuracy and integrity message
GGA	Global positioning system (GPS) fix data message
GLL	Geographic position - Latitude/longitude message
GLONASS	Globalnaya Navigazionnaya Sputnikovaya Sistema (Russian GNSS)
GND	Electrical Ground
GNS	GNSS fix data message
GNSS	Global Navigation Satellite System
GPS	Global Positioning System
GRS	GNSS range residuals message
GSA	GNSS DOP and active satellites message
GSV	GNSS satellites in view message
HDT	Heading true message
Hex	Hexadecimal
IEC	International Electrotechnical Commission
IMO	International Maritime Organisation
INT	Internal
IPx6	Ingress Protection (to powerful water jets)
IPx7	Ingress Protection (1m immersion for 30 minutes)
ISO	International Standards Organisation
Kt	Knots
LAT	Latitude

LCD	Liquid Crystal Display
LON	Longitude
LR	Long-range
MKD	Minimum Keyboard and Display
MMSI	Maritime Mobile Service Identity
MOB	Man Overboard
NC	Normally Closed (electrical)
NAV	Navigation
NM	Nautical Miles
NMEA	National Marine Electronics Association
PDF	Portable Document Format
PGN	Parameter Group Number
PI	Presentation Interface
RAIM	Receiver Autonomous Integrity Monitoring
RED	Radio Equipment Directive
RF	Radio Frequency
RMC	Recommended minimum specific GNSS data message
ROT	Rate of Turn
RX	Receive
SD	Secure Digital
SOG	Speed Over Ground
SOLAS	Safety of Life at Sea
SRM	Safety Related Message
TCP	Transmission Control Protocol
TCPA	Time to Closest Point of Approach

List of abbreviations

TDMA	Time Division Multiple Access
THS	True heading and status message
TNC	Threaded Neill–Concelman (a type of connector)
TPI	Threads per Inch
TX	Transmit
UDP	User Datagram Protocol
UHF	Ultra High Frequency
UTC	Co-ordinated Universal Time
VBW	Dual ground/water speed message
VDM	All VDL AIS messages received
VDO	AIS own-ship broadcast data
VHF	Very High Frequency
VSWR	Voltage Standing Wave Ratio
VTG	Course over ground and ground speed message
WGS84	World Geodetic System 1984
WEEE	Waste Electrical & Electronic Equipment
WiFi	Wireless networking technology

Table of contents

1	Notices	11
1.1	Safety warnings	11
1.2	General notices.....	12
1.3	Regulatory statements.....	13
2	Introduction	17
2.1	About AIS.....	17
3	Installation and configuration.....	19
3.1	What's in the box?	19
3.2	Preparing for installation	19
3.3	Installation procedures.....	20
3.4	Connecting the equipment.....	29
3.5	Grounding the AIS transceiver.....	37
3.6	Connection to an NMEA 2000 network (optional).....	38
3.7	USB Connection	39
3.8	Turning the AIS transceiver on	39
3.9	Passwords and security	39
4	Operation	41
4.1	Display and controls.....	41
4.2	Button functions	42
4.3	Adjusting display brightness	42
4.4	Changing navigation status.....	43
4.5	Menu navigation.....	43
4.6	Information displayed.....	46
4.7	Configuring vessel information.....	58
4.8	Configuring voyage information	60
4.9	Confirming correct operation.....	60

4.10	Communication test	61
4.11	Displaying AIS targets.....	62
4.12	Micro SD card data input.....	64
4.13	WiFi Feature.....	66
5	STEDS mode	69
5.1	STEDS Operation	69
5.2	STEDS Presentation interface	78
6	Technical information.....	81
6.1	Interface circuits.....	81
6.2	Output drive capability of bi-directional ports	82
6.3	DGNSS Port.....	83
6.4	Input data sentence formats.....	83
6.5	AIS Transceiver overall dimensions.....	84
6.6	GNSS Antenna drawing	85
6.7	Transmission intervals	85
6.8	Interface sentences.....	87
6.9	Unused fields	91
6.10	Proprietary sentences	92
6.11	Priority of sensor ports	92
6.12	Compatibility mode.....	95
6.13	Message 24 content.....	95
6.14	NMEA 2000 PGN List	95
6.15	Troubleshooting	99
7	Junction box accessory	103
7.1	What's in the box.....	103
7.2	Installation.....	103
7.3	Connecting external equipment	106
7.4	Technical information	107

8	Technical specification.....	109
8.1	Assessed requirements	109
8.2	Product category	110
8.3	Physical.....	111
8.4	Environmental	112
8.5	Electrical	112
8.6	Display and user interface	112
8.7	Internal GNSS.....	114
8.8	TDMA Transmitter.....	114
8.9	TDMA Receiver.....	114
8.10	DSC Receiver	115
8.11	RF Connections	115
8.12	WiFi.....	116
8.13	Data interface.....	116
8.14	Power and data connector information	117
8.15	Open source licences	117
9	Installation record	119
9.1	Vessel details.....	119

List of figures and tables

Figure 1	The AIS network	17
Figure 2	What's in the box?	19
Figure 3	Typical AIS transceiver connection.....	21
Figure 4	Mounting the AIS transceiver.....	23
Figure 5	Desk mounting the AIS transceiver	24
Figure 6	Panel mounting the AIS transceiver	25
Figure 7	GNSS Antenna location.....	26
Figure 8	GNSS Antenna connection.....	27
Figure 9	VHF Antenna location.....	28
Figure 10	VHF Antenna connection.....	29
Figure 11	Serial input port connection	30
Figure 12	14-way connector cable wiring connections	31
Table 1	14-way connector serial data ports.....	31
Figure 13	Silent mode switch connections.....	32
Figure 14	Serial bi-directional port connection.....	33
Figure 15	18-way connector cable wiring connections	34
Table 2	18-way connector serial data ports.....	34
Table 3	Alarm relay connections	35
Figure 16	Power connection	36
Table 4	Power supply connections	36
Figure 17	Grounding the AIS transceiver.....	37
Figure 18	NMEA 2000 Screen.....	38
Figure 19	Enter password screen.....	40
Figure 20	AIS Transceiver front panel	41
Figure 21	Home page menu screen	43
Figure 22	Main menu structure	45
Figure 23	Display layout	46
Table 5	Status indicators	48
Figure 24	alert icons	49
Table 6	Warnings in priority order.....	51
Table 7	Cautions.....	55
Figure 25	Vessel dimension measurement.....	59
Figure 26	Target list screen	62
Figure 27	AIS target symbols displayed	63

Figure 28	Micro SD card Socket	65
Table 8	EAIS ASM presentation and VDL access	70
Figure 29	Operating mode screen	71
Table 9	EAIS Asset type list.....	78
Figure 30	Input port schematic.....	81
Figure 31	Data output port schematic.....	82
Figure 32	AIS Transceiver dimensions	84
Figure 33	GNSS Antenna	85
Table 10	IEC 61162 Transmission interval for periodic sentences.....	86
Table 11	IEC 61162 Sentences input and output	87
Table 12	ALR Alerts.....	90
Table 13	Unused fields	92
Table 14	Port priority order	93
Table 15	PGN List.....	98
Table 16	Troubleshooting	101
Figure 34	Junction box - What's in the box	103
Figure 35	Junction box connections.....	105
Figure 36	Connecting external equipment	106
Figure 37	GNSS Antenna position	120

1 Notices



When reading this manual please pay particular attention to warnings marked with the warning triangle symbol shown on the left. These are important messages for safety, installation and usage of the AIS transceiver.

1.1 Safety warnings



This equipment must be installed in accordance with the instructions provided in this manual. Failure to do so may seriously affect its performance and reliability. It is strongly recommended that a trained technician installs and configures this product.



This product must be connected to protective ground via the ground connection point. It is essential that the ground connection point is used in all installations, regardless of what other equipment is connected. The ground connection point must be bonded to protective ground using as short a connection as possible.



This equipment is intended as an aid to navigation and is not a replacement for proper navigational judgement. Information provided by the equipment must not be relied upon as accurate. User decisions based upon information provided by the equipment are done so entirely at the users own risk.



Do not install this equipment in a flammable atmosphere such as in an engine room or near to fuel tanks.



It is recommended that this product is not installed in direct sunlight or under a windshield where it may be subject to excessive solar heating.



Do not attempt to service this equipment as doing so may cause fire, electric shock or malfunction and will invalidate the warranty. If any malfunctions are detected contact your supplier or service agent.



NOT ALL SHIPS CARRY AIS. The Officer of the Watch should always be aware that other ships and, in particular, leisure craft, fishing vessels and warships may not be fitted with AIS. Any AIS equipment fitted on other ships as a mandatory requirement may also be switched off based on the Master's professional judgement.

1.2 General notices

1.2.1 Position source

All marine AIS transceivers utilise a satellite based location system.



The accuracy of a GNSS position fix is variable and affected by factors such as the antenna positioning, how many satellites are used to determine a position and for how long satellite information has been received.

1.2.2 Compass safe distance

The compass safe distance of this AIS transceiver is 0.5m or greater for a 0.3° deviation.

1.2.3 Safe operating distance

The safe operating distance of this AIS transceiver is 20cm from the antenna.

1.2.4 Product category

This product is categorized as 'exposed' in accordance with the definitions provided in IEC 60945.

1.2.5 Disposal of AIS transceiver and packaging

Please dispose of this AIS transceiver in accordance with the European WEEE Directive or with the applicable local regulations for disposal of electrical equipment. Please dispose of the packaging in an environmentally friendly manner.

1.2.6 Accuracy of this manual

This manual is intended as a guide to the installation, setup and use of this product. If you are in any doubt about any aspect of this product, please contact your dealer.

1.3 Regulatory statements

1.3.1 Declaration of Conformity

The manufacturer of this product declares that this product is in compliance with the Radio Equipment Directive (2014/53/EU) and as such, displays the CE mark. The RED declaration of conformity is provided as part of the documentation pack.

The manufacturer declares that this product complies with the United Kingdom Conformity Assessed requirements and as such, displays the UKCA mark.

The UKCA declaration of conformity is provided as part of this documentation pack.



1.3.2 Marine Equipment Directive

The manufacturer of this product declares that this product is in compliance with the Marine Equipment Directive Annex A.1/4.32 Universal Automatic Identification System as defined by Directive 2014/90/EU, and as such complies with the following IMO resolutions:

1.3.3 US Coast Guard

This product has been assigned Marine Equipment Directive Module B number 165.155/EC0168

1. DISTRIBUTION C. Distribution authorized to U.S. Government Agencies and their contractors; Administrative/Operational Use (date of determination shall be contract award date)

2. **WARNING** - This document contains technical data whose export is restricted by the Arms Export Control Act (Title 22, U.S.C., Sec 2751, et seq.) or the Export Administration Act of 1979, as amended, Title 50, U.S.C., App. 2401 et seq. Violations of these export laws are subject to severe criminal penalties. Disseminate in accordance with the provisions of DoD Directive 5230.25.

3. **DESTRUCTION NOTICE** - For classified documents, follow the procedures in DoD 5220.22-M, National Industrial Security Program Operating Manual, Chapter 5, Section 7, or DoD 5200.1-R, Information Security Program, Chapter 6, Section 7. For unclassified, limited documents, destroy by any method that will prevent disclosure of contents or reconstruction of the document

1.3.4 Quality Standards

This product has been developed and manufactured under a certified ISO9001:2008 Quality Management System (BSI certificate number FS548550).

The following quality standards apply to the product:

ANSI-Z1.4 - Sampling Procedures and Tables for Inspection by Attributes.

ANSI/NCSL Z540.3-2006, Requirements for the Calibration of Measuring and Test Equipment.

1.3.5 FCC Notice



This equipment has been tested and found to comply with the limits for a class A digital device, pursuant to part 15 of the FCC Rules. These limits are designed to provide reasonable protection against harmful interference in a residential installation. This equipment generates, uses and can radiate radio frequency energy and, if not installed and used in accordance with the instructions, may cause harmful interference to radio communications.

This device complies with part 15 of the FCC Rules. Operation is subject to the following two conditions:

- (1) This device may not cause harmful interference, and
- (2) This device must accept any interference received, including interference that may cause undesired operation.

Changes or modifications not expressly approved by the party responsible for compliance could void the user's authority to operate the equipment.

1.3.6 Industry Canada Notice



This device complies with Industry Canada licence-exempt RSS standard(s). Operation is subject to the following two conditions:

1. This device may not cause interference, and
2. This device must accept any interference, including interference that may cause undesired operation of the device.

This Class A digital apparatus complies with Canadian ICES-003.

Le présent appareil est conforme aux CNR d'Industrie Canada applicables aux appareils radio exempts de licence. L'exploitation est autorisée aux deux conditions suivantes:

1. L'appareil ne doit pas produire de brouillage, et
2. L'utilisateur de l'appareil doit accepter tout brouillage radioélectrique subi, même si le brouillage est susceptible d'en compromettre le Fonctionnement.

Cet appareil numérique de la classe A est conforme à la norme NMB-003 du Canada.

2 Introduction

2.1 About AIS

The marine Automatic Identification System (AIS) is a location and vessel information reporting system. It allows vessels equipped with AIS to automatically and dynamically share and regularly update their position, speed, course and other information such as vessel identity with similarly equipped vessels. Position is derived from GNSS and communication between vessels is by VHF digital transmissions.

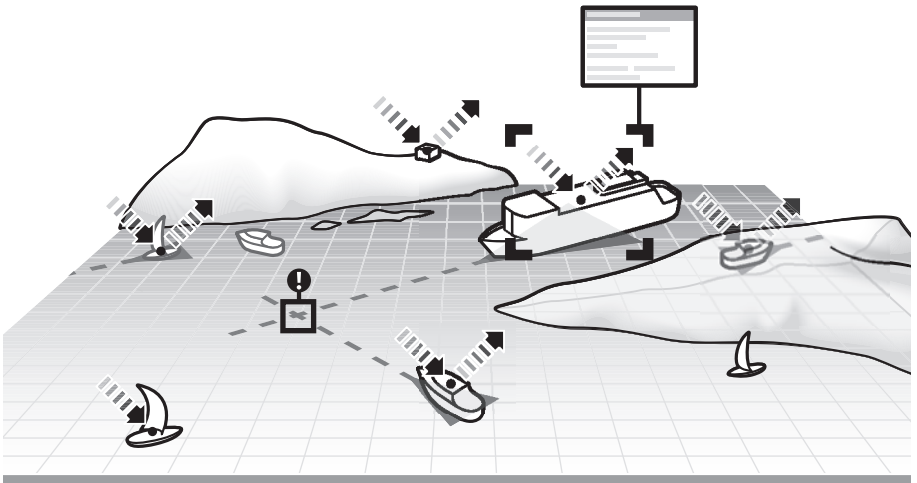

Figure 1 The AIS network

3 Installation and configuration

3.1 What's in the box?

Please ensure all items are present and if any of the items are missing please contact your dealer.

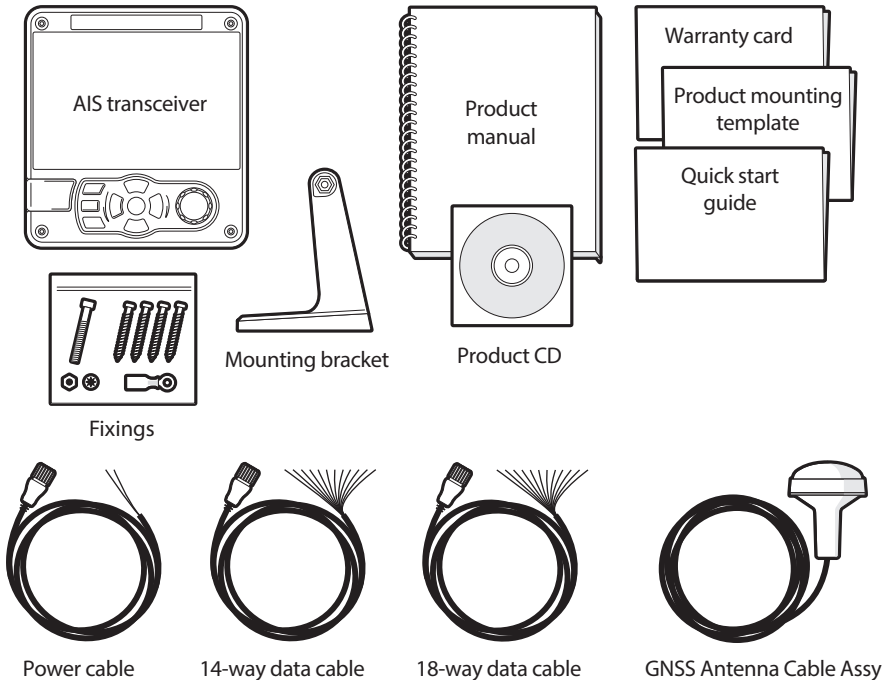

Figure 2 What's in the box?

3.2 Preparing for installation

In addition to the items provided with the AIS transceiver the following items will be required to complete the installation:

3.2.1 VHF Antenna

Connection of a suitable VHF antenna will be required for the AIS transceiver to operate. The antenna cable should be terminated with a PL-259 (or UHF) connector. A surge arrestor should be fitted in line with VHF antenna connector. See section 3.3.3 for more information.

Please take note of the warnings listed at the start of this manual regarding the installation and use of antennas.

3.2.2 Antenna cables

The supplied GNSS antenna is provided with 10 metres (32.8ft) of cable. If this is not sufficient to reach between the desired GNSS antenna location and the AIS transceiver you will require an extension cable. Please contact your dealer for details.

3.2.3 GNSS Antenna mount

A mounting bracket is required for the supplied GNSS antenna.

3.2.4 Data interface cables

Suitable screened, multi core cable will be required to connect the ships sensor (DGNSS, Gyro etc.) data ports to the AIS transceiver.

3.3 Installation procedures

Before beginning installation of your AIS transceiver, please ensure that you read all of the instructions in this manual.

The following sections explain the installation process step by step for each of the main system elements. A typical system and connection diagram is provided in Figure 3.

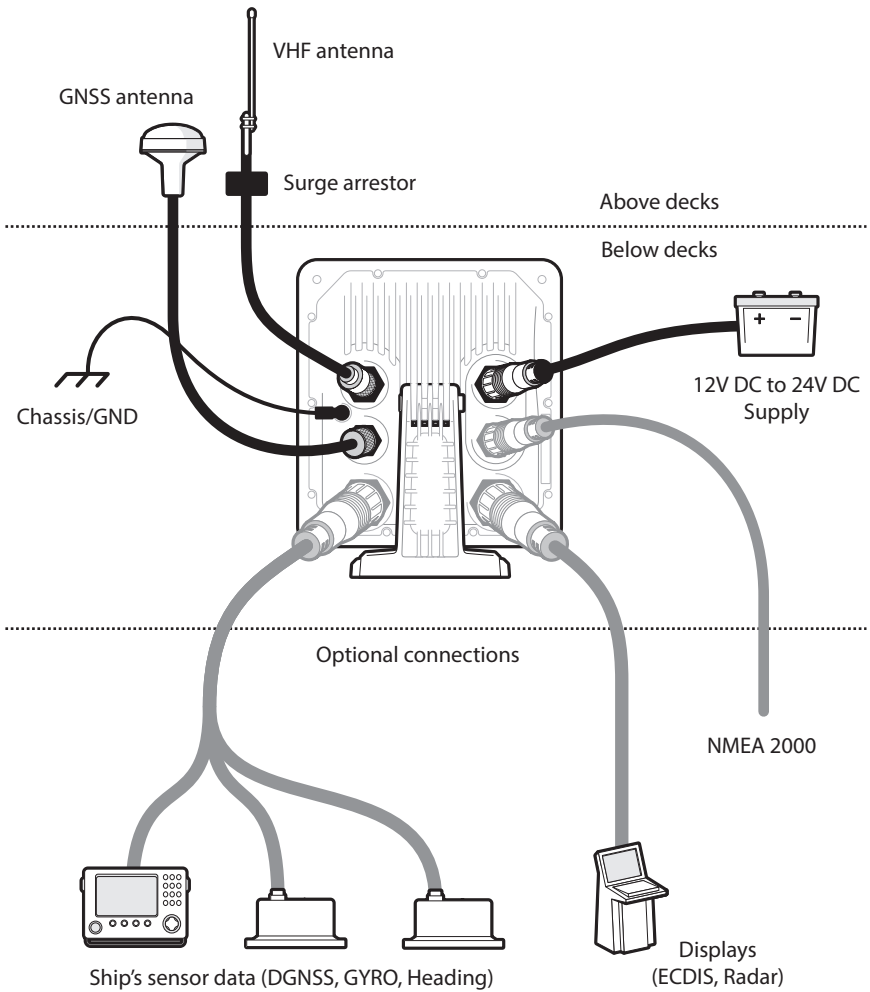

Figure 3 Typical AIS transceiver connection

3.3.1 Step 1 - Installing the AIS transceiver

Please note the following guidelines when selecting a location for your AIS transceiver:

- The AIS transceiver must be fitted in a location where it is at least 0.5m (1ft 8ins) from a compass or any magnetic device.
- There should be adequate space around the AIS transceiver for routing of cables. See Figure 32. for details of the AIS transceiver dimensions.
- The ambient temperature around the AIS transceiver should be maintained between -25°C and +55°C (5°F to 131°F). Ensure adequate ventilation is present when panel mounting the AIS transceiver.
- The AIS transceiver is supplied with four self-tapping screws for attachment of the AIS transceiver to a suitable surface using the supplied bracket. Please refer to Figure 5. for guidance.
- The AIS transceiver can be panel mounted using the four self-tapping screws provided. Please refer to Figure 6. for guidance. Access behind the panel is required when using this mounting option.
- The AIS transceiver should be mounted in a location where the display is visible to the user at the position from which the vessel is normally operated.

A pilot plug connection option is included in the 18-way connector located on the rear panel of the AIS transceiver. To provide the pilot plug an optional accessory can be purchased.

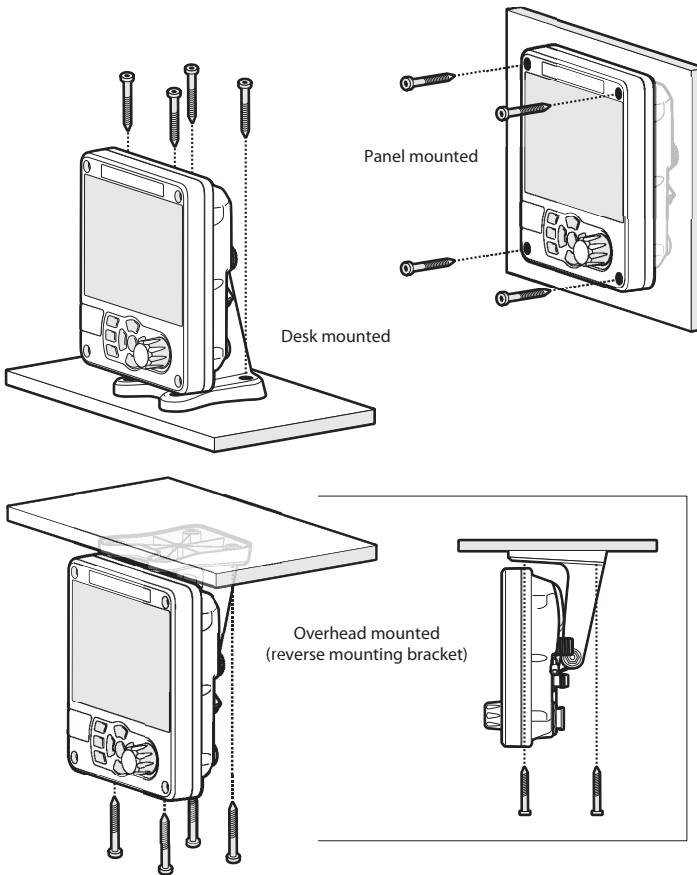

Figure 4 Mounting the AIS transceiver

Refer to Figure 32. for dimensions. A drilling and cutting template is provided with the AIS transceiver.

To panel mount the unit it is necessary to remove the 4 off socket cap screws recessed in front of the unit. See Figure 6.

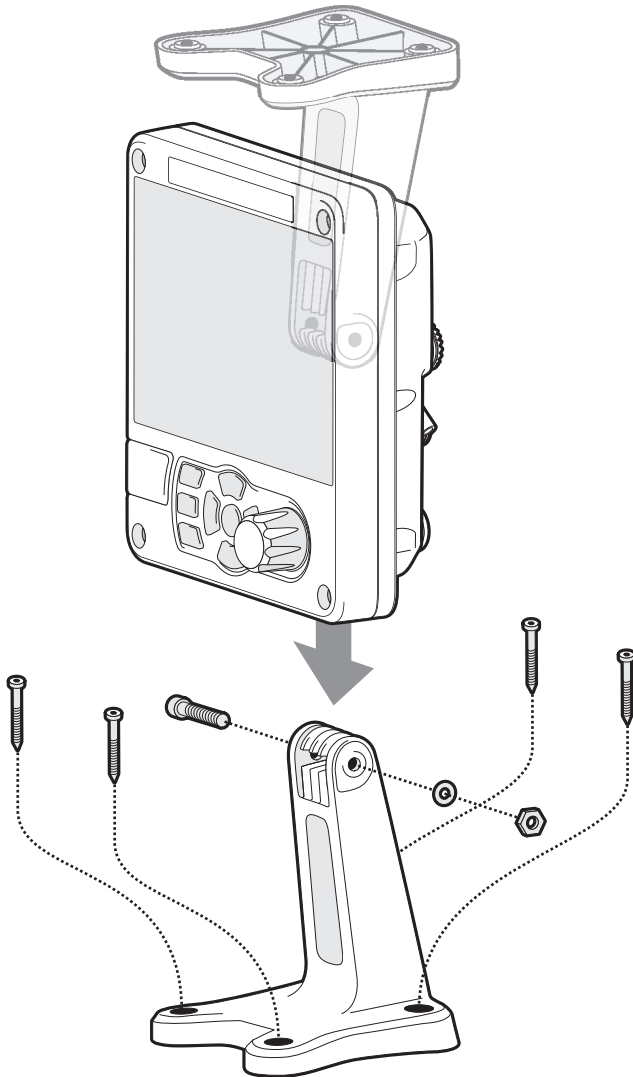

Figure 5 Desk mounting the AIS transceiver

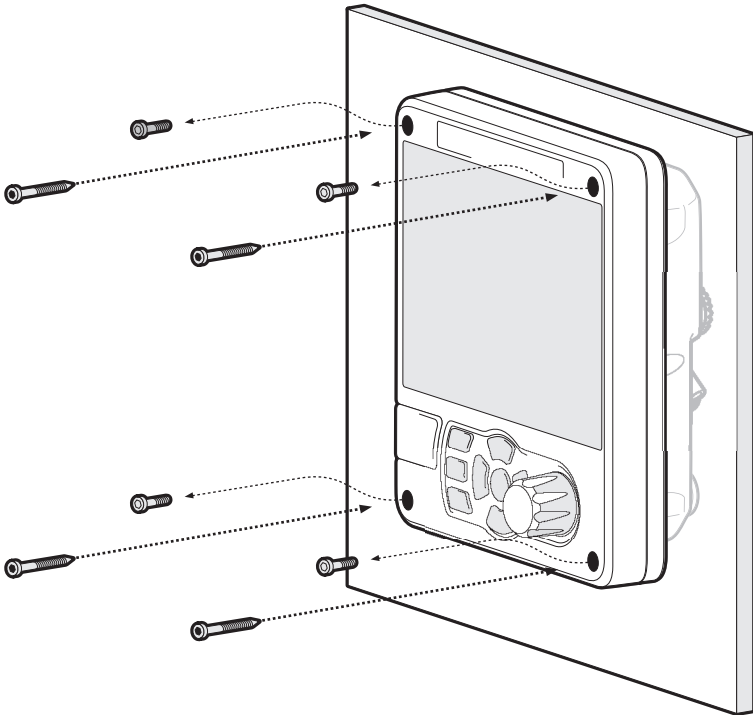

Figure 6 Panel mounting the AIS transceiver

3.3.2 Installing the GNSS antenna

For mounting the GNSS antenna supplied with your AIS transceiver you will require a one inch 14 TPI pole mount. Contact your dealer to source a mount suitable for the installation location.

Please note the following guidelines when selecting a location for the GNSS antenna:

- The GNSS antenna mount should be secured to a rigid surface.

- The GNSS antenna should be located where it has a clear, unobstructed view of the sky overhead.
- The GNSS antenna should be mounted as high as possible, however it is not recommended to mount the antenna on the top of a high mast where the motion of the vessel will cause the antenna to move and potentially reduce the accuracy of the GNSS position.
- Route the GNSS antenna cable to the AIS transceiver. If extension cables are required all junctions should be made using appropriate co-axial connectors and made watertight.

Connect the GNSS antenna cable to the GNSS connector on the AIS transceiver.

GNSS Antenna should be at least 5m (16ft) from radar or satellite communication antennas. It should also be away from the radar beam path and mounted on a rigid surface.

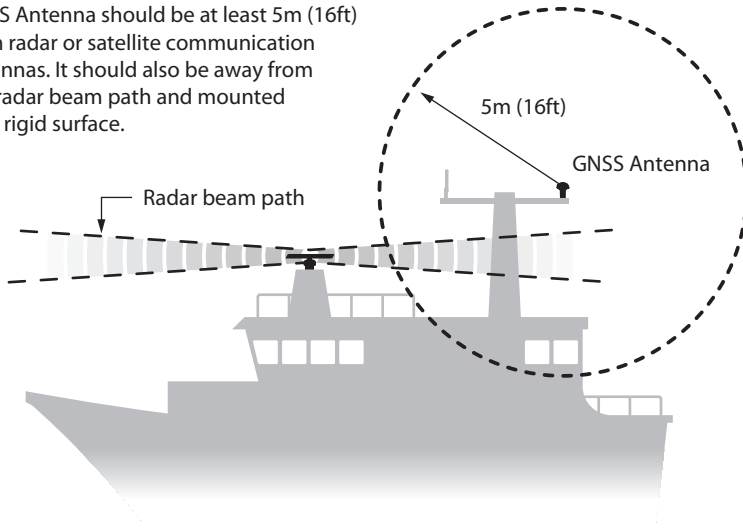

Figure 7 GNSS Antenna location

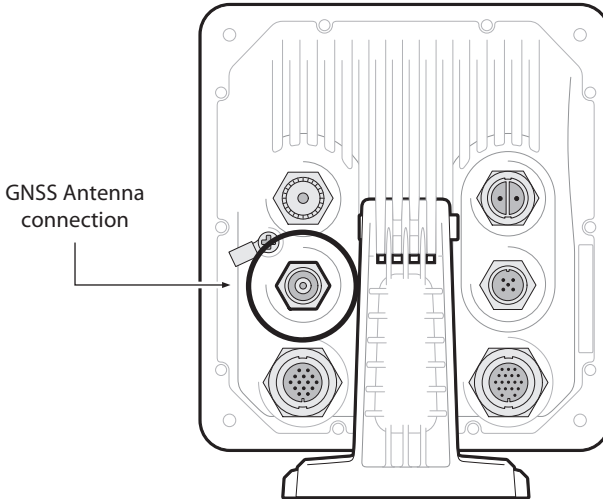

Figure 8 GNSS Antenna connection

3.3.3 Installing the VHF antenna

Please note the following guidelines when selecting and locating the AIS VHF antenna:

- The VHF antenna should be located as high as possible and positioned as far from other antennas as possible.
- The VHF antenna should have omnidirectional vertical polarization.
- Where possible the VHF antenna should be installed at least 3m (10ft) away from other transmitting radio, satellite and radar antennas.
- Ideally the AIS VHF antenna should be mounted directly above or below the ship's primary VHF radiotelephone antenna, with no horizontal separation and with a minimum of 2m vertical separation. Refer to Figure 9. for further guidance.

- The VHF antenna cable should be kept as short as possible to minimize signal loss. High quality, low loss co-axial cable appropriate to the installation location should be used.
- The VHF antenna cable should be terminated in a PL-259 co-axial connector for connection to the AIS transceiver.
- Any outdoor installed connectors in the antenna cables should be waterproof by design.
- Antenna cables should be installed in separate signal cable channels at least 10cm (4ins) away from power supply cables. Crossing of cables should be done at right angles and sharp bends in the antenna cables should be avoided.
- It is recommended that a suitable surge arrestor is fitted in-line with the VHF antenna connector.

Connect the VHF antenna cable to the VHF connector on the AIS transceiver as shown in Figure 10.

VHF Antenna should be at least 3m (10ft) from other transmitting radio, satellite and radar antennas.

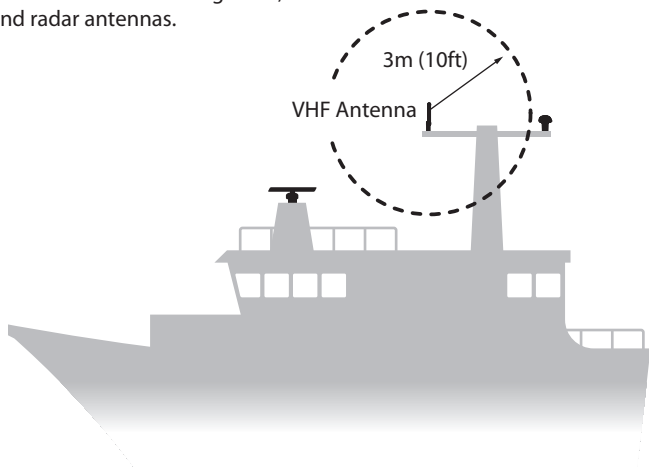

Figure 9 VHF Antenna location

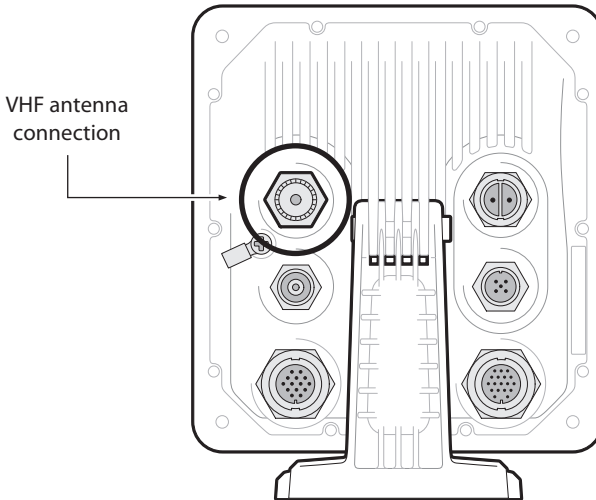

Figure 10 VHF Antenna connection

3.4 Connecting the equipment

3.4.1 Data connections

The AIS transceiver is supplied with a 2m (6.5 ft) 18-way data cable and a 2m (6.5 ft) 14-way data cable for connection of the AIS transceiver to external sensors and equipment.

3.4.2 Sensor configuration

The AIS transceiver has six NMEA 0183 (IEC 61162-1/2) data ports for connection of ship's sensors and display equipment as described in Table 1. and Table 2.

There are three input-only ports for ship's sensor data and three bi-directional high speed ports for connection of display equipment such as radar or electronic chart displays.

3.4.3 Data input ports (14-way connector)

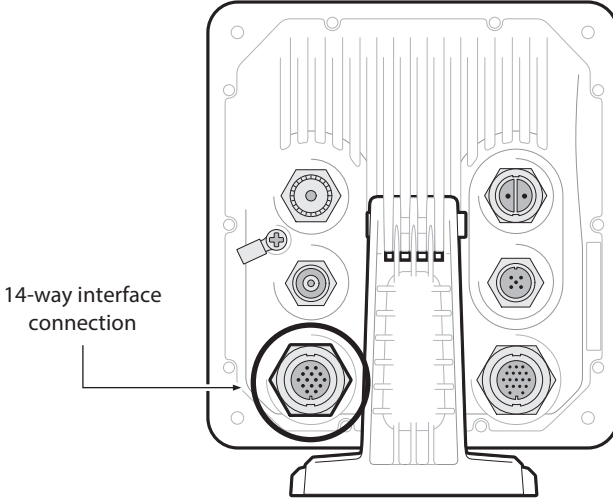

Figure 11 Serial input port connection

SIGNAL	WIRE COLOUR	PIN
BLUE SIGN N	BLACK	1
BLUE SIGN P	BROWN	3
SILENT N	BLUE	6
SILENT P	RED	7
SENSOR 1 RX B	ORANGE	2
SENSOR 1 RX A	PURPLE	5
SENSOR 1 COM	GREEN	8
SENSOR 2 RX B	WHITE	9
SENSOR 2 RX A	WHITE / BLACK	12
SENSOR 2 COM	GREY	11
SENSOR 3 RX B	YELLOW	14 </td
SENSOR 3 RX A	RED / BLACK	13
SENSOR 3 COM	PINK	10
CHASSIS	DRAIN WIRE	4

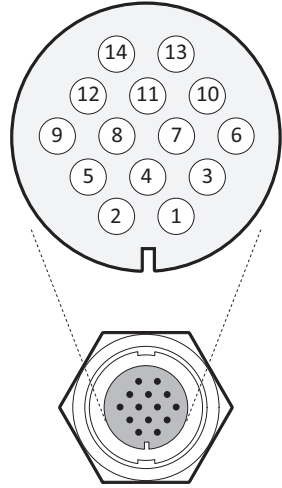

Figure 12 14-way connector cable wiring connections

Data port	Function	Type	Default baud rate
4	Sensor 1 input (DGNSS - COG / SOG / LAT / LON)	Receive only	4800
5	Sensor 2 input (Rate of Turn)	Receive only	4800
6	Sensor 3 input (Gyro heading)	Receive only	4800

Table 1 14-way connector serial data ports

Note: Any unused ports should be terminated by a 120 Ohm resistor across RX A and RX B signals.

3.4.4 Silent mode switch

To activate the Silent mode switch, apply a voltage of between 2V and 30V to the SILENT P (Pin 7) and SILENT N (Pin 6) terminals of the 14-way connector.

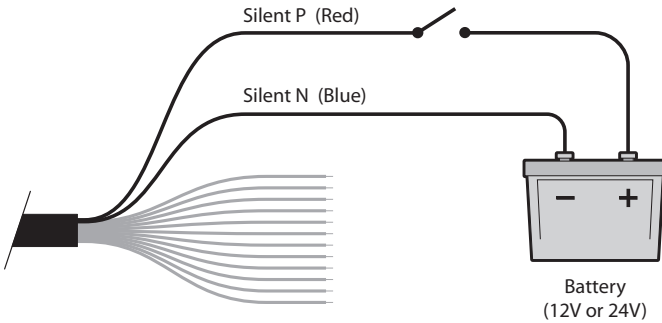

Figure 13 Silent mode switch connections

3.4.5 Data bi-directional ports (18-way connector)

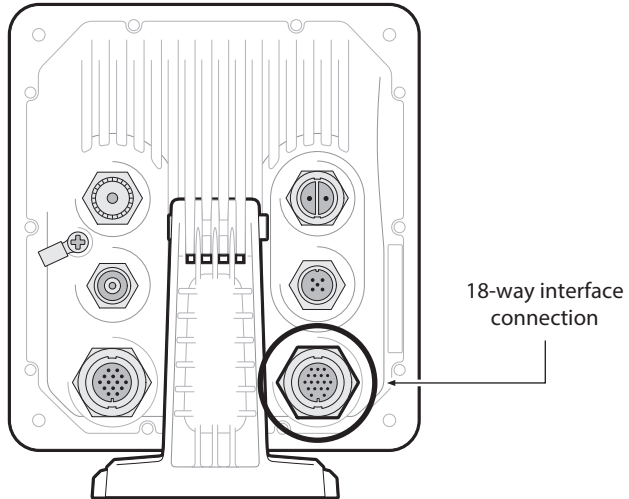

Figure 14 Serial bi-directional port connection

SIGNAL	WIRE COLOUR	PIN
LR DGNSS TX B	ORANGE	3
LR DGNSS TX A	BROWN	4
LR DGNSS RX B	PURPLE	7
LR DGNSS RX A	BLUE	8
LR DGNSS COM	BLACK	1
PILOT TX B	RED	2
PILOT TX A	RED / WHITE	5
PILOT RX B	PINK	6
PILOT RX A	YELLOW	10
PILOT COM	GREEN	11
ALM NC	GREY	16
ALM COM	WHITE	12
EXT DISPLAY TX B	ORANGE / WHITE	13
EXT DISPLAY TX A	BLACK / WHITE	17
EXT DISPLAY RX B	BROWN / WHITE	14
EXT DISPLAY RX A	YELLOW / WHITE	18
EXT DISPLAY COM	GREEN / WHITE	15
CHASSIS	DRAIN WIRE	9

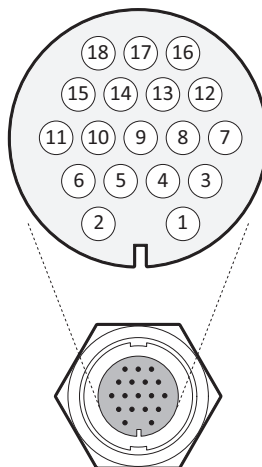

Figure 15 18-way connector cable wiring connections

Data port	Function	Type	Default Baud rate
1	External display / ECDIS	Bi-directional	38400
2	Pilot port	Bi-directional	38400
3	Long-range / DGNSS / Ext Display	Bi-directional	38400

Table 2 18-way connector serial data ports

Note: Any unused ports should be terminated by a 120 Ohm resistor across RX A and RX B signals. COMMON signals should be grounded.

All sensor ports can be configured via the Interface settings menu which can be found under the 'Home' > 'System settings' > 'Interfaces' menu option.



If an external GNSS device which does not provide a DTM sentence is connected to the AIS transceiver and the AIS transceiver is configured to require DTM sentences, the external GNSS data will not be accepted by the AIS transceiver. If no DTM sentence is required the WGS84 datum will be used as a coordinate origin and the external GNSS device must be configured to output position using this datum.

3.4.6 Alarm relay connections

The AIS transceiver also provides connections to the alarm relay contacts. The alarm relay connections are described in Table 3.

Alarm connection	Function	Contact rating
COM	Alarm relay common connection	2A at 220VDC or 60W maximum
NC	Alarm relay normally closed connection	

Table 3 Alarm relay connections

3.4.7 Power connection

Power is connected to the AIS transceiver via the supplied 2-way power cable as shown in Figure 16.

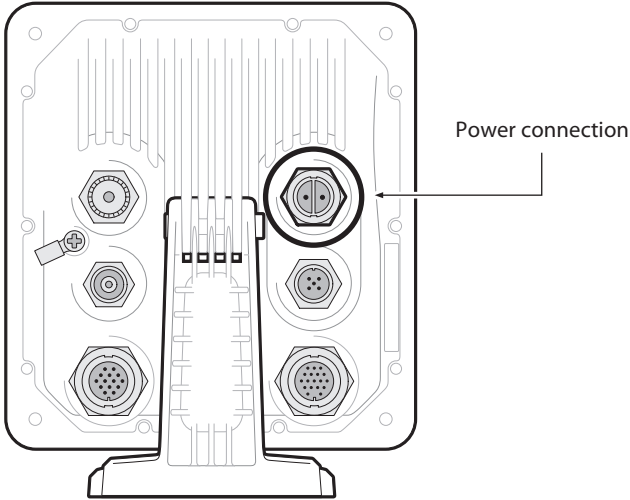

Figure 16 Power connection

Wire colour	Function	Connect to
Red	Power supply +	12VDC to 24VDC power supply from ships emergency power source*
Black	Power supply -	Power supply ground

Table 4 Power supply connections

*Connection to an emergency power source is an IMO requirement for SOLAS vessels.

The power supply current ratings and recommended fusing or circuit breaker currents are as follows:

- A 12VDC supply should be able to provide a peak current of 4.3A and be fused at 10.0A.
- A 24VDC supply should be able to provide a peak current of 2.2A and should be fused at 6.3A.

3.5 Grounding the AIS transceiver

An M4 grounding screw and ring crimp are provided in the fixing kit to allow connection to the grounding point on the rear of the AIS transceiver chassis as indicated in Figure 17.

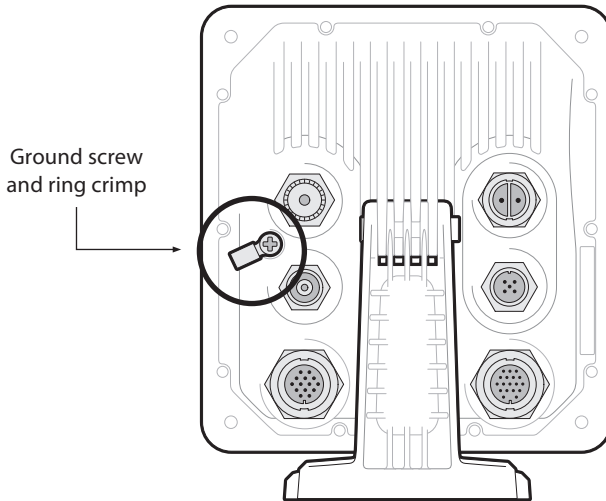

Figure 17 Grounding the AIS transceiver



This product **must** be connected to protective ground via the ground connection point. It is essential that the ground connection point is used in **all installations**, regardless of what other equipment is connected. The ground connection point must be bonded to protective ground using as short a connection as possible.

3.6 Connection to an NMEA 2000 network (optional)

The AIS transceiver can be connected to an NMEA 2000 network by a suitable NMEA 2000 network cable available from your local dealer. If your vessel has an NMEA 2000 network please refer to the relevant documentation for your NMEA 2000 equipment. Sensors providing position, ROT, or true heading will be displayed on the NMEA 2000 screen, where three separate source menus will allow for independent configuration based on the data type supported.

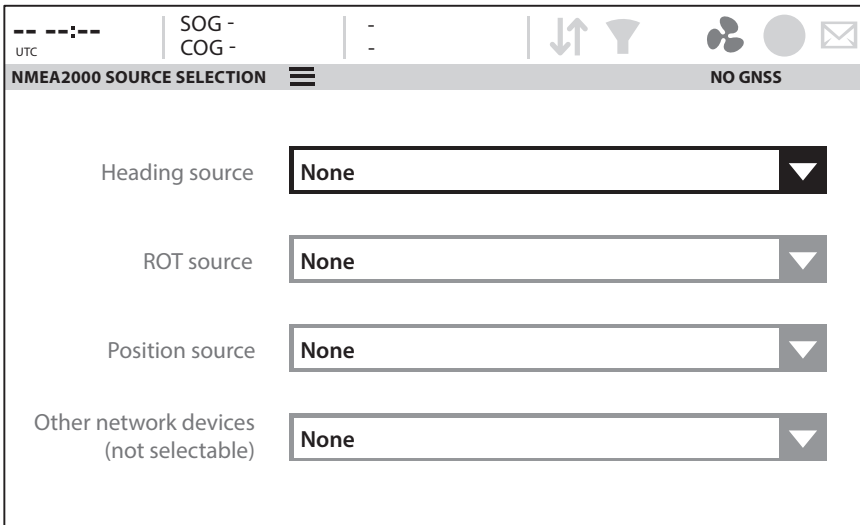

Figure 18 NMEA 2000 Screen

Once connected, and with your chart plotter also connected you will be able to receive AIS targets on your chart plotter. A list of supported PGNs is provided at the rear of this document.

3.7 USB Connection

An optional USB cable is available for connection to a PC or Mac. The USB connector can be connected directly to the USB port on the PC or Mac via the optional USB cable.



If the USB connection is removed from the PC or Mac during use you must reset the connection before further use. To reset the connection, disconnect then reapply power to the AIS before closing and relaunching any PC or Mac applications using the USB connection. Finally, reconnect the USB cable between the PC or Mac and the AIS transceiver

3.8 Turning the AIS transceiver on

The AIS transceiver does not have an On / Off switch and will operate immediately that power is applied to the unit.

3.9 Passwords and security

Certain important information stored within the AIS transceiver cannot be changed without knowledge of the password. When trying to edit any of this protected information you will be prompted to enter the password.

The password entry screen is shown in Figure 19. Highlight the required character, then press 'Select' to enter that character. When all characters of the password have been entered, select 'OK'.

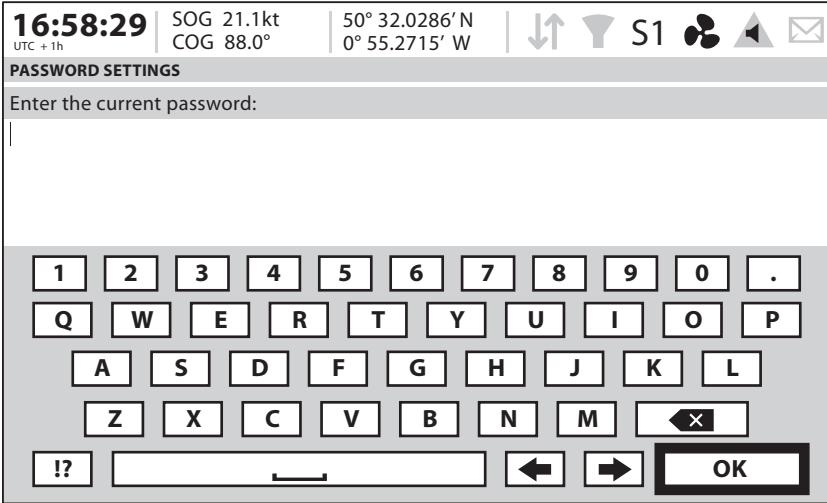

Figure 19 Enter password screen

Following configuration of the AIS transceiver the password should be changed from its default value of '0000' (four zeros) to another alpha numeric code. Password change is carried out by selecting 'Home' > 'System settings' > 'User Settings' > 'Password'.

The password should be recorded on the installation record found in Section 9.

4 Operation

Please read the warning notices at the front of this manual before operating the AIS transceiver.

4.1 Display and controls

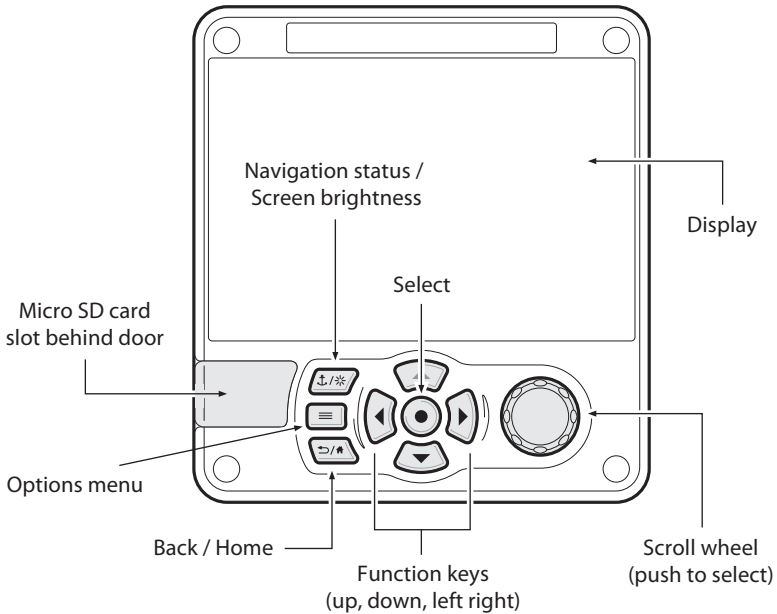

Figure 20 AIS Transceiver front panel

The front panel of the AIS transceiver is shown in Figure 20 with each control marked.

4.2 Button functions

Scroll wheel. This is used to highlight information presented on the display. The scroll wheel can also be pressed to confirm data entry or select information.

Navigation status / Screen brightness key. When pressed with a short press will go to the Navigation status screen. When pressed and held it will go to the '*Display brightness*' screen.

Options menu key. Provides access to additional features and relevant shortcuts on certain screens.

Back / Home key. When pressed with a short press cancels the current operation and moves to the previous menu or if pressed and held will return to the home screen.

Select key. When pressed selects the current option highlighted on the screen.

Up, down, left and right function keys. Provide an alternative means of navigating around the screen.

Speaker. The speaker is located behind the '*Scroll*' wheel and can provide an audible sound when a key is pressed, a message is received, or an alert is activated. Sounds can be enabled or disabled via the Sound Settings menu.

Micro SD card. The Micro SD card socket (behind the door) is provided to allow uploading of new software to the AIS transceiver.

Display. The display shows essential AIS operating information and allows for configuration of the AIS transceiver via the menus.

4.3 Adjusting display brightness

Press and hold the '*Navigation status / Screen brightness*' key. The screen will change to the '*Display Settings*' screen.

Once the display settings screen is active the display brightness can be altered from maximum to minimum via the scroll wheel. Should the display be switched off prior to activation of the display setting menu the screen will increase to default brightness to allow the user to see the screen.

When in this mode it is possible to switch off the screen via a single, long press on the 'Select' key. A press of any button restores the screen to its default brightness.

Whilst the screen is switched off all internal functions of the AIS transceiver continue to operate as normal.

4.4 Changing navigation status

Press the 'Navigation status / Screen brightness' key. The screen will change to the Navigation menu screen. Move to the desired navigation status icon to select it.

4.5 Menu navigation

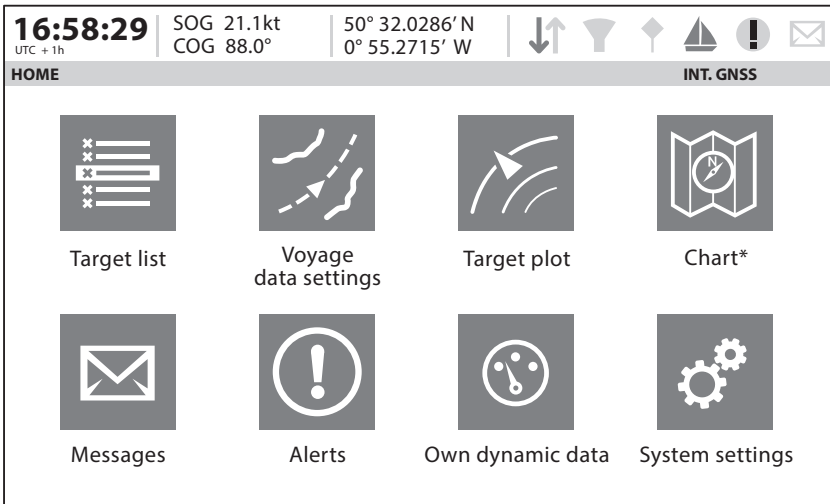

* The Chart feature is only enabled when this Class A AIS transceiver is operating on a non-SOLAS or Inland vessel.

Figure 21 Home page menu screen

4.5.1 Main / Sub menus

Menus are displayed as a set of icons which can be navigated by using the controls. Selection of an icon will then display the information beneath in accordance with Figure 22. Pressing the '*Back / Home*' key will exit the menu.

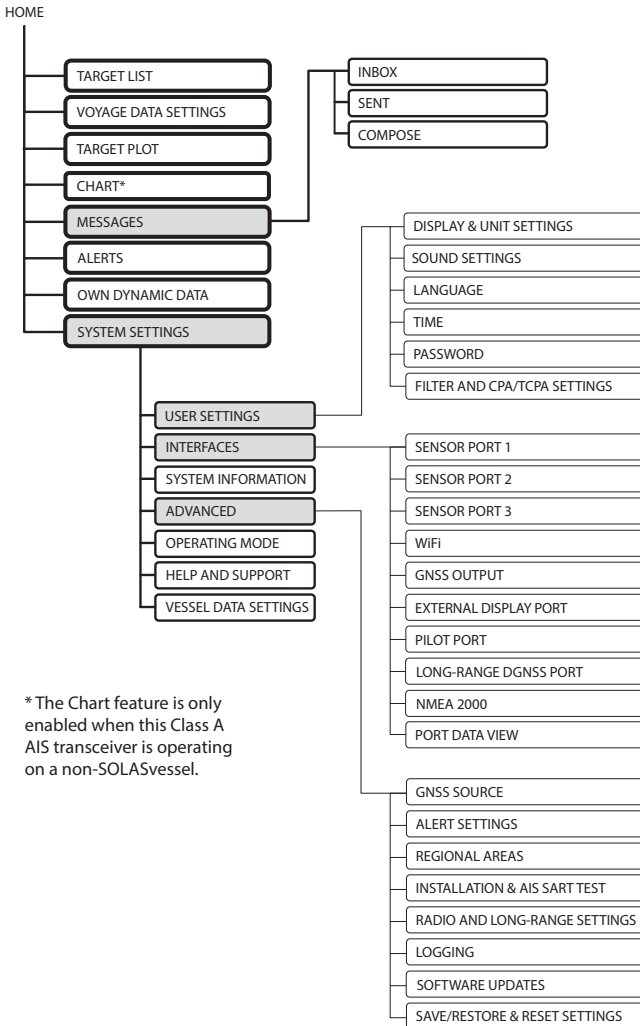

Figure 22 Main menu structure

4.5.2 Data entry screens

Some screens allow you to enter data, such as vessel parameters. On these screens you navigate to the desired field and select the appropriate menu item. Some data entry items require a password, this is shown by means of a 'Padlock' icon. Pressing the 'Back / Home' key will exit these menus.

4.5.3 Keyboard / Keypad screens

Some screens require text or numeric entry. When these are selected, a virtual keyboard is displayed which can be used to enter text or numbers.

4.5.4 Options menu

On certain screens, the Options Menu will bring up a further list of functions specific to that screen. This is indicated by this icon. ☰

4.6 Information displayed

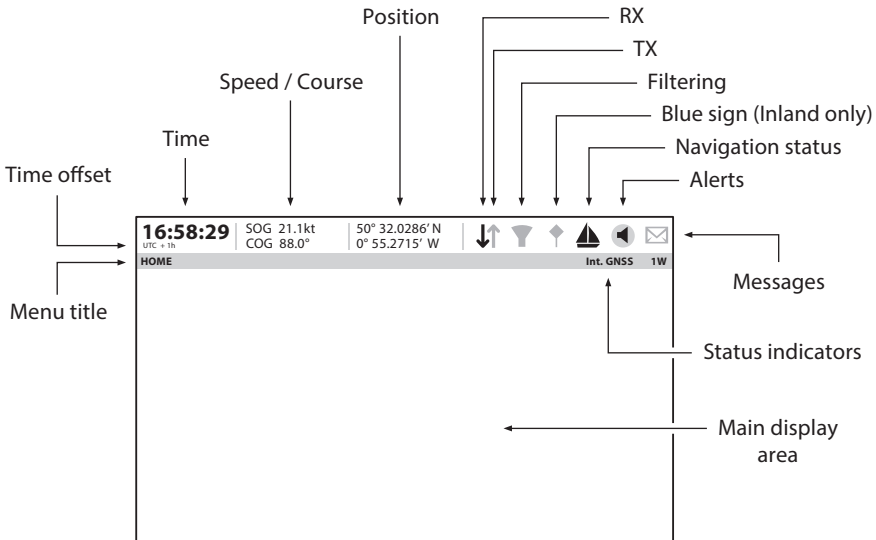

Figure 23 Display layout

4.6.1 Menu title

Refers to the current menu displayed from Figure 22.

4.6.2 Time

Time derived from GNSS satellites or AIS Base Stations.

4.6.3 Time offset

Offset from UTC, set on the *'Time'* menu.

4.6.4 Speed / Course

Vessel speed and course as taken from GNSS satellite data.

4.6.5 Position

Vessel position taken from GNSS source.

4.6.6 Icons

RX - Illuminates to show receiving an AIS message.

TX - Illuminates to show transmission of an AIS message.

Filtering - Illuminated to show that target filter settings apply.

Navigation status - Vessel navigation status.

Alerts - Displays an alert icon to show the presence of AIS alerts.

Messages - Displays an envelope icon with a number to show the presence of AIS messages received See menu *'Messages'*.

Status indicators - Displays the AIS transceiver status as shown in Table 5.

STEDS indicator - Displays the STEDS mode.

Icon	Description
1W	Shown when the transmitter is set to 1W mode.
INT GNSS	Shown when the internal GNSS receiver has a valid position fix.
EXT GNSS	Shown when the connected external GNSS receiver has a valid position fix.
NO GNSS	Shown when there is no valid internal or external position fix.
INT DGNSS	Shown when the internal GNSS receiver has a valid differential position fix.
EXT DGNSS	Shown when the connected external GNSS receiver has a valid differential position fix.

Table 5 Status indicators

4.6.7 Onboard system self-test

4.6.7.1 Watchdog

A software and hardware 'watchdog' continually monitor the correct operation of the unit. In the very unlikely event of internal real time software tasks failing to execute, the software watchdog which monitors the completion of all internal software tasks will restart the software. In the even more unlikely event that the software watchdog itself fails to maintain the hardware watchdog, then the hardware watchdog will restart the entire unit.

4.6.7.2 Built in Integrity Tests and alerts

The AIS transceiver performs self-checking functions continuously. If a self-check fails a display will appear on the screen notifying the operator of this. If the feature is enabled via the '*Sound Settings*' menu, the occurrence of an

Alert will be accompanied by a notification sound. The alert can be acknowledged via the on-screen message. The list of currently active AIS alerts can be displayed by accessing the 'Alerts' menu. If an alert occurs please try restarting the transceiver or checking the relevant connections in the first instance. If any alert condition persists, contact your dealer or installer.

The Alerts icon indicates the alert status. When there are no active alerts the blank icon is displayed, see Figure 24. If a warning alert occurs, the display changes to show the unacknowledged warning alert icon. Once the warning alert has been acknowledged, the acknowledged warning alert icon is displayed. If the only active alerts are caution alerts, the caution alert icon is displayed. Specific alerts can be disabled in the Alert settings menu if the relevant sensors are not installed.

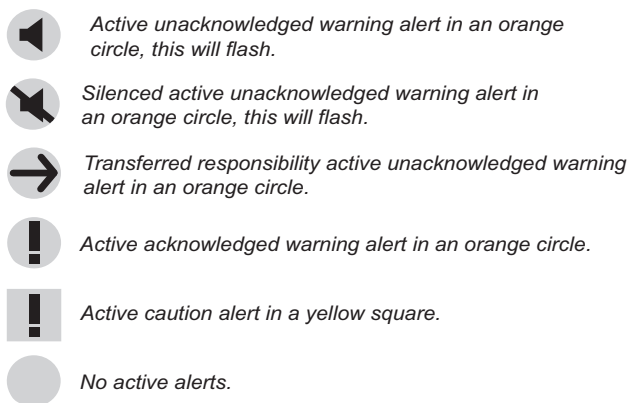

Figure 24 alert icons

When the transceiver is used with a Central Alert Management (CAM) system, other equipment in the system is able to take responsibility for the transceiver's warning alerts (caution alerts are unaffected). The transferred responsibility active unacknowledged warning alert icon is used to indicate when this has occurred. A CAM system also allows other equipment to silence alerts produced by the transceiver. This is indicated by the silenced active unacknowledged warning alert icon.

All supported alerts are Category B (as per IEC 62923-1 - Bridge Alert Management) and are listed in Table 6 and Table 7. This product supports Escalation of a Warning as a Warning only. This product supports the silencing and responsibility transfer of warning alerts by external CAM equipment via the IEC 61162 (NMEA 0183) serial ports only.

Alert	Alert Additional Information	Alert Identifier (Instance ID)	Description
Locating device	Check AIS targets	3108 (1)	An active locating (AIS SART, MOB or PLB) message has been received. The device will be displayed as the top item in the target list. Select this item to see the location of the device.
Transceiver fail	Not transmitting, check AIS	3008 (1)	This alert will occur if the MMSI has not been configured. This alert can occur if the radio hardware has failed. Please restart the transceiver. The alert will be cleared if the transmitter recovers normal operation.

Alert	Alert Additional Information	Alert Identifier (Instance ID)	Description
Transceiver fail	Not receiving, check AIS	3008 (2)	This alert occurs should the receiver hardware malfunction. Please restart the transceiver. If the receiver returns to normal operation this alert will be cleared.
Lost position	Own ship position not transmitted	3015 (1)	This alert occurs if the AIS transceiver has no valid position information from any connected sensor. Please check the connections to the sensor.

Table 6 Warnings in priority order

Alert	Alert Additional Information	Alert Identifier (Instance ID)	Description
Impaired radio	Reduced coverage (antenna VSWR)	3116 (1)	This alert occurs if there is a problem with your antenna or antenna connection. Please check the antenna and cable to ensure it is fully connected

Alert	Alert Additional Information	Alert Identifier (Instance ID)	Description
Impaired radio	Ch1 inoperative, check AIS Ch2 inoperative, check AIS DSC inoperative	3116 (2) 3116 (3) 3116 (4)	This alert occurs should the receiver hardware malfunction. Please restart the transceiver. If the receiver returns to normal operation this alert will be cleared.
Sync in fallback	Check AIS for UTC time synchronisation	3113 (1)	This alert indicates that the transmitter is no longer directly synchronized with the GNSS receiver. This may be because the GNSS receiver cannot receive sufficient satellites. Please check the supplied GNSS antenna is installed correctly.
Lost ext EPFS	Check external position sensor	3003 (1)	This alert occurs if the position from the external Electronic Position Fixing System (i.e. GNSS) is invalid or lost. Please check the connections to the sensor.

Alert	Alert Additional Information	Alert Identifier (Instance ID)	Description
Missing COG	Not transmitting COG	3119 (1)	This alert occurs if the AIS transceiver has no valid Course Over Ground information from any connected sensor. Please check the connections to the sensor.
Missing SOG	Not transmitting SOG	3119 (2)	This alert occurs if the AIS transceiver has no valid Speed Over Ground information from any connected sensor. Please check the connections to the sensor.
Missing Heading	Not transmitting Heading	3119 (3)	This alert occurs if the AIS transceiver has no valid heading information from any connected sensor, or if the heading is undefined. Please check the connections to the sensor.
Missing ROT	Not transmitting Rate of Turn	3119 (4)	This alert occurs if the AIS transceiver has no Rate Of Turn information from connected sensors or via internal calculation. Please check the connections to the sensor.

Alert	Alert Additional Information	Alert Identifier (Instance ID)	Description
Doubtful GNSS	Int/Ext GNSS position mismatch	3013 (1)	This alert occurs if the difference in position reported by the internal and external GNSS receivers is too large. Check the vessel dimensions and GNSS antenna locations have been entered correctly.
Doubtful heading	Difference with COG exceeds limit	3013 (2)	This alert occurs if the difference between the course over ground and heading data is greater than 45° for more than 5 minutes. This alert only occurs if the vessel speed over ground is greater than 5 knots. Please check the connections to the sensor.
Wrong NavStatus	Check NavStatus setting	3019 (1)	This alert will occur if the navigation status is in conflict with the current speed of the vessel. For example the alert will activate if the Navigation status is set to moored, but the vessel speed is greater than 3 knots. Correct the navigation status to clear this alert.

Alert	Alert Additional Information	Alert Identifier (Instance ID)	Description
Lost MKD	Cannot display safety related messages	3009 (1)	This alert occurs should the MKD hardware malfunction. Please restart the transceiver. If the MKD returns to normal operation this alert will be cleared.

Table 7 Cautions

4.6.8 Messages

AIS text messages and Safety Related Messages (SRMs) can be received from other AIS equipped vessels and also sent to specific vessels (addressed messages) or sent to all vessels in range (broadcast messages).

Reception of an AIS text message is indicated by the presence of the message icon at the top of the screen. This icon is shown whenever there are unread AIS text messages. Messages can be reviewed and replied to via the Inbox.

The AIS transceiver can store up to a maximum of 20 messages in the Inbox and 20 messages in the Sent folder. If the number of messages exceeds 20 then the oldest message will be overwritten.

When a Safety Related Message is received the user will be notified immediately with a pop-up showing the message. Standard text messages are not displayed on receipt, however the message icon will be displayed at the top of the screen.

AIS messages can be viewed, created and transmitted from the 'Messages' menu.

The available options are:

Compose - takes you to the message composition screen

Inbox - takes you to the received message list view, where 20 messages can be saved.

Sent - shows a list of recently sent messages.

To compose a new message, select the type of message from the drop down menu and the destination. This can be by directly entering the MMSI, or by selecting from a list of visible targets.

The message text is entered using the on-screen keyboard.



Class B AIS transceivers are permitted to receive broadcast SRMs and broadcast text messages, however this function is not mandatory. Some Class B AIS transceivers are not able to receive addressed SRM or text messages. There is therefore no guarantee that text messages or SRMs sent by this device to a Class B AIS transceiver will be received.

4.6.9 Long-range messages

If the AIS transceiver is connected to a long-range communication system via the long-range communications port then long-range interrogations may be received. These are requests for information from a distant base station beyond normal AIS operation range.

The AIS transceiver can be configured to automatically respond to Long-range (LR) interrogations, or you can opt to respond to any interrogation manually. Automatic response is the default setting, but this can be changed on the '*Home*' > '*System settings*' > '*Advanced*' > '*Radio and Long-range settings*' menu.

When a Long-range interrogation is received you will be alerted by an on-screen pop-up message.

In automatic response mode simply review and acknowledge the notification screen using '*Acknowledge*'. In manual response mode you should review the request and select either the '*Respond*' or '*Decline*' option as appropriate.

4.6.10 Chart

The Chart feature is only enabled when this Class A AIS transceiver is operating on a non-SOLAS vessel.

The AIS transceiver contains an application which will display AIS targets received, along with its own vessel position on a chart style plot.

The chart can be scrolled up, down, left, and right using the *'Function'* keys. Zooming in and out is via the *'Scroll'* wheel.

Targets can be selected by moving the cross hairs over a target and pressing the *'Select'* key.

The *'Options'* menu is also available for more advanced features.

Within the *'Options'* menu, the chart can be oriented to either North, Heading, or Course Up. The chart can be set so that the own vessel position is always in the centre of the screen.

The chart can be de-cluttered by hiding filtered targets, or vessel names from the display.

SOG vectors can also be displayed on the screen if this item is selected from the *'Options'* menu.

Some of the layers displayed on the chart can be removed to provide more clarity on the display. The *'Chart Settings'* screen provides a way of modifying these.

It is possible to record and display your own vessel track on the Chart feature, showing up to 30 days of voyage history. It can also be downloaded to an SD card from the Logging menu.

The chart feature is an aid for the display of information only and should not be used for vessel navigation.

4.6.11 Help and support screen

This screen is available from the *'Home'* > *'System Settings'* menu and provides contact information for the product manufacturer.

It also provides relevant information from the User Manual.

4.6.12 User settings screen

From this screen, it is possible to set the display brightness, set the display to a day or night colour scheme, set the operating units to metric or nautical, and configure the sounds emitted by the device. It is also possible from this screen to set the UTC time offset, change the password, change the filter settings and display the menus in a number of non-English languages.

4.7 Configuring vessel information

4.7.1 Pre-configuration checks

To proceed with configuration the steps in Section 3 should already have been completed.

4.7.2 Configuring vessel identification information

The AIS transceiver must be configured with information about the vessel on which it is installed prior to operation. The following information is required to be entered in the *'Home' > 'system settings' > 'Vessel data settings'* menu:

- MMSI - Vessel MMSI number, this can usually be found on the ships VHF radio license and should be the same MMSI as used for the VHF / DSC radio.
- Ship name (limited to 20 characters)
- Callsign - Vessel radio call sign (limited to 7 characters)
- IMO - Vessel's IMO identification number (if applicable)
- Ship type - Selected from the menu provided.
- Internal dimensions of the location of the GNSS antenna connected directly to the AIS transceiver (Internal GNSS).
- External dimensions of the location of an optional GNSS antenna connected to the AIS transceiver via an NMEA interface.

4.7.3 Configuring the internal GNSS receiver

The internal GNSS receiver can be configured to operate in one of six modes:

- GLONASS and GPS – in this mode the position fix is derived from both the GLONASS and GPS network in parallel. This mode is the default setting.
- GPS and BeiDou – in this mode the position fix is derived from both the GPS and BeiDou systems in parallel.
- BeiDou and GLONASS – in this mode the position fix is derived from both the BeiDou and GLONASS systems in parallel.

- GPS – in this mode the position fix is derived from the GPS system only.
- GLONASS – in this mode the position fix is derived from the GLONASS system only.
- BeiDou - in this mode the position fix is derived from the BeiDou system only.

The operating mode can be selected from the 'GNSS source' option in the 'Home' > 'System settings' > 'Advanced' settings menu.

The antenna dimensions should be entered in metres according to the diagram provided in Figure 25.

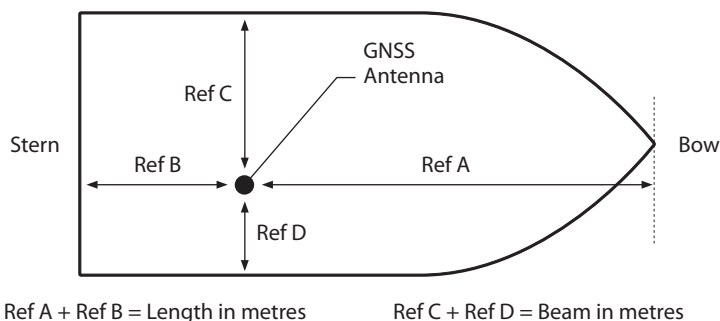

Figure 25 Vessel dimension measurement

4.8 Configuring voyage information

4.8.1 Configure voyage related data

The AIS transceiver must be configured with information about its voyage prior to operation. To enter the vessel identification information select the '*Home*' > '*Voyage Data settings*' option.

The following information is required:

- Destination - Ships next destination port (limited to 20 characters).
- ETA - Estimated time / date of arrival at destination (using UTC time).
- Static draught - Maximum present static draught to the nearest 1/10th of a metre.
- Navigation status - Navigational status selected from the icons on the screen.

The following information is optional:

- Extension dimensions - enter the dimensions of the craft being towed
- Persons on board - Number of crew on board.

4.9 Confirming correct operation

Following entry of the vessel and voyage information the AIS transceiver will commence normal operation. Correct operation should be verified as follows:

1. Select the '*Own dynamic data*' option from the '*Home*' menu.
2. Check that the displayed position, course, speed and heading are correct by comparing to the display associated to the connected position source and other data sources.
3. Check that the '*TX*' icon flashes periodically.
4. If the vessel is in an area where other AIS equipped vessels are present press the '*Back / Home*' key and select '*Target list*' to check that data from other AIS equipped vessels is displayed.
5. Go to the '*Home*' > '*System settings*' > '*System Information*' screen and select '*Hardware status*', check that the supply voltage, forward power, and antenna VSWR are acceptable. A good VSWR is 3:1. A good Forward Power is 41dBm.

The AIS transceiver is now operational and should remain powered unless authorised by the local maritime authority. The installation record at the rear of this manual should be completed and left on board the vessel.

4.10 Communication test

It is possible to conduct an AIS communication test with another AIS equipped vessel. This test sends an AIS message to another vessel and checks for a response. The AIS transceiver will display a list of vessels from which one can be selected for a communication test.

This feature can be selected from the *'Home' > 'System settings' > 'Advanced' > 'Installation & AIS SART test'* menu.

From this screen you can also switch on or off the display of test messages from AIS Search and Rescue Transceivers. If *'Display AIS SART Test Messages'* is set to On, messages from AIS SARTs in Test mode will be displayed.

4.11 Displaying AIS targets

4.11.1 Target list

The *'Target list'* screen is the primary screen for displaying AIS targets received. This is the first screen displayed when the unit is switched on, but can also be accessed from the *'Target list'* option on the *'Home'* menu.

16:58:29 UTC +1h		SOG 21.1kt COG 88.0°		50° 32.0286' N 0° 55.2715' W			
TARGET LIST					INT. GNSS		
NAME/MMSI	Range	Bearing	CPA	TCPA	Type	Age	
DUBLIN FISHER	3.15NM	120.8°	3.15NM	-		1m 50s	
PROXIMITY CRAFT	15.5NM	22.6°	15.5NM	-		1m 47s	
ATLANTIC PRIDE	6.9NM	37.20	6.9NM	-		0m 1s	
212222222	6.7NM	313.4°	6.7NM	-		0m 36s	
EMSLAKE	-	-	-	-		0m 45s	
PIER 4	5.2NM	86.6°	5.2NM	5h 38m		0m 6s	
444110175	35.8NM	167.3°	35.8NM	-		0m 5s	
Visible: 12 Filtered out: 0							

Figure 26 Target list screen

By default the *'Target list'* is sorted by range but can be sorted on any column by using the left and right *'Function'* keys to select a column and pressing the *'Select'* key to sort either in ascending or descending order. Navigation up and down the list is via the up and down arrow keys or scroll wheel. Selecting a highlighted target using the Select key will bring up more details of that target. The *Options* menu on this screen provides additional actions which can be performed on the *'Target list'*.

Different symbols are shown for an AIS target depending on the type of target and its status, these are shown in Figure 27. These symbols are common to the 'Target list' and 'Target plot' displays.



Figure 27 AIS target symbols displayed

4.11.2 Target filtering

From the 'Target list' options menu, if 'Show Filter Settings' is selected, a screen is displayed indicating which filter parameters can be set to reduce the amount of data displayed on-screen. This screen can also be accessed through 'Home' > 'System settings' > 'User settings'.



Filters can be toggled on and off on the 'Target list' by pressing the 'Options menu' key and selecting 'Toggle Filters On / Off'. The bottom line of the 'Target list' shows how many targets are visible or filtered out. If a filter is set, the filter icon is displayed at the top of the screen.

The Filters icon does not represent CPA/TCPA settings.

4.11.3 CPA/TCPA Settings

The AIS transceiver can be configured to identify approaching vessels which fall within certain limits. The Closest Point of Approach (CPA) defines a boundary around the own vessel upon which, if breached, will trigger an alert. Time to Closest Point of Approach (TCPA) can only be set if CPA is set, and will trigger the alert if the time to the CPA limit is breached.

These parameters are set on the 'Home' > 'System settings' > 'User settings' > 'Filtering and CPA/TCPA Settings' menu.

The target list shows targets which trigger the CPA/TCPA alert in red.

These CPA/TCPA figures are calculated solely on AIS data and should not be used for anti-collision purposes.

Note: Setting the CPA/TCPA filter will not activate the Filters Icon.

4.11.4 Target plot

The '*Target plot*' screen shows the location of other AIS equipped vessels and shore stations relative to your own vessel. The '*Target plot*' screen provides a basic overview of AIS targets and should not be regarded as a substitute for display of AIS information on a dedicated electronic chart display system (ECDIS).

The plot range can be adjusted by rotating the scroll wheel which cycles through the ranges 0.1NM up to 100NM. The range relates to the radius of the outer range ring shown on the screen.

Individual targets can be selected by using the arrow keys. When selected a square outline will appear around the target and the vessel details will be shown on the left-hand side of the screen.

By pressing the options menu key, additional display features can be selected. If the Own Vessel Details option is selected the left-hand side of the screen will change to show own vessel dynamic data.

If the MOB Details Display option is selected, the target plot will change to show only AIS-MOB, AIS-SART, and AIS-EPIRB devices. The left-hand side of the screen will show the range and relative bearing to whichever target is currently highlighted using the arrow keys.

4.12 Micro SD card data input

On the front of the AIS transceiver under the cover on the lower left-hand side is a socket for a Micro SD memory card. See Figure 28. This can be used to upgrade the unit firmware, display detailed charts or to log port data. Note the orientation of the Micro SD card, which is critical to ensure the product is not damaged.

SDSC and SDHC card types are supported, up to a maximum capacity of 32GB. The file system needs to be formatted to FAT or FAT32.

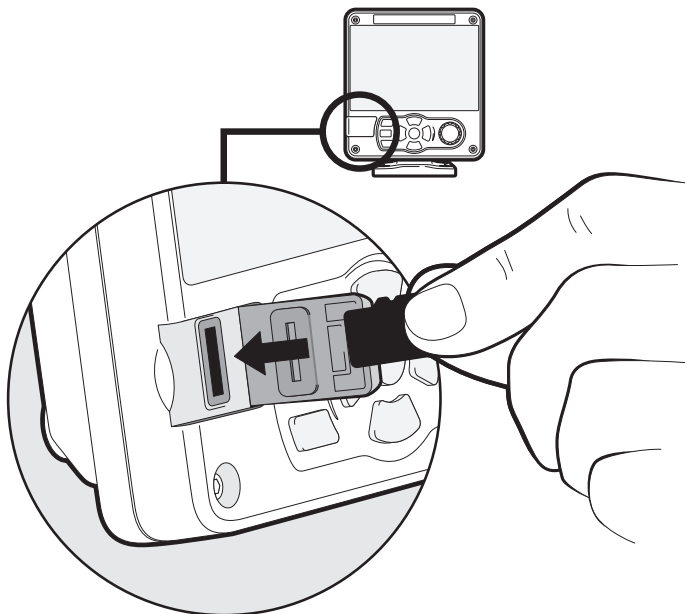

Figure 28 Micro SD card Socket

4.12.1 Loading new charts

The AIS transceiver always contains a basic low resolution world chart. More detailed resolution charts can be purchased and overlaid onto the AIS transceiver's chart display.

The AIS transceiver will read only C-MAP MAX format Micro SD cards. See your dealer for available charts for your region.

Insert a C-MAP Micro SD card into the Micro SD card socket. The AIS transceiver will then automatically overlay that higher resolution chart region onto the relevant region on the AIS transceiver's world chart.

Remove the Micro SD card and the region will revert back to the basic world chart.

4.12.2 Upgrading the unit firmware

If a Micro SD card that contains valid upgrade firmware is inserted into the card socket, the unit will recognize the new firmware and will display a message asking you if you want to install it. The system will guide you to the appropriate menu screen, where the firmware update can be applied.

4.12.3 Logging ports to the Micro SD card

If a Micro SD card is inserted into the card socket, the AIS transceiver can be configured to output specific data to the card. This is accessed from the individual port menu (from the *'Home' > 'System settings' > 'Interfaces' menu.*) If the *'Log port to SD'* option is set to *'On'*, data will be output from that port to the Micro SD card, if one is inserted into the card socket. Only one port can be logged to the Micro SD card at a time. It is also possible to save a copy of the current screen to the Micro SD Card for diagnostics purposes by pressing and holding the rotary controller for at least 3 seconds.

4.12.4 Saving / Loading settings

From the *'Home' > 'System Settings' > 'Advanced' > 'Save / Restore & Reset settings'* menu, all system settings and AIS transceiver configuration data can be saved to the Micro SD card, if one is inserted into the card socket. Settings previously saved can be restored, thus restoring the AIS transceiver to a previous configuration. *'Reset all settings'* will restore the unit to its factory defaults and is protected by the unit password.

4.13 WiFi Feature

The AIS transceiver provides features to operate with vessel WiFi networks, or to create its own network. Access the WiFi menu through *'Home' > 'System settings' > 'Interfaces' > 'WiFi'*.

4.13.1 Client mode

If client mode is selected, the AIS transceiver will search for available WiFi networks to connect to. If one is selected a password may be required, and upon connection the details of the connection will be shown in the bottom right corner of the screen. Once a WiFi connection is made, the AIS transceiver will

output a range of NMEA 0183 sentences over the selected WiFi port to any connected devices.

4.13.2 Access point mode

If the AIS transceiver is configured as a WiFi access point (AP) it will create its own WiFi network, allowing other WiFi enabled devices to connect to it. Up to 5 simultaneous connections are supported. Once connections are made, a range of NMEA 0183 sentences will be transmitted from the AIS transceiver to any connected devices. The following parameters are set by default:

- Protocol: TCP
- DHCP: Enable
- IP address: 192.168.50.1
- Port: 49200
- SSID: Class A AIS <unique number>
- Encryption: WPA-2
- Channel: 6

4.13.3 Advanced WiFi features

Within the 'WiFi' screen, certain parameters can be changed such as Channel Number, Protocol, Port, Encryption, etc. These are recommended for advanced users only.

WiFi is switched off by selecting 'Disable' in the 'Select operating mode' box.

5 STEDS mode

5.1 STEDS Operation

5.1.1 STEDS operating modes

When STEDS operation is enabled the AIS Transceiver may operate in the following modes:

- Receive Only
- Normal Transmit
- Restricted Transmit

In *Receive-Only*, all broadcast and own-vessel addressed AIS messages received over the standard AIS VDL channels shall be reported via the presentation interface. The AIS shall not transmit any AIS messages either autonomously or by interrogation. In addition, channel management via DSC or AIS VDL shall not be applied.

In *Normal Transmit* the AIS shall operate as a AIS Class A transceiver, transmitting standard AIS Class A position and static data reports in the normal manner defined by the relevant AIS standards. In addition, EAIS application specific messages presented to the AIS at the presentation interface as defined in Table 1 may be transmitted.

In *Restricted Transmit* only EAIS application specific messages (ASM) presented to the AIS at the presentation interface as defined in Table 1 may be transmitted.

The current STEDS operating mode of the AIS is indicated on the MKD.

- S1 indicates Receive Only
- S2 indicated Normal Transmit
- S3 indicated Restricted Transmit

DAC	FID	Type	Presentation Period (seconds)	Presentation Timeout (seconds)	Transmit Period (seconds)	VDL Access Method
366	4	TOI	5	10	15	ITDMA
366	5	TOI	20	40	60	ITDMA
366	6	TOI	60	120	180	ITDMA
366	7	TOI	600	-	On demand	RATDMA
366	8	TOI	On demand	-	On demand	RATDMA
366	9	ACK	On demand	-	On demand	RATDMA
366	10	SITREP	5	10	15/30 (SOG dependant)	ITDMA
366	11	Static Data	360	-	On demand	RATDMA
366	Other	-	On demand	-	On demand	RATDMA

Table 8 EAIS ASM presentation and VDL access

With respect to Table 8, for each FID, with DAC:366 ASM requests must be presented to the AIS at the periodicity defined in *Presentation Period*. The most recently presented data for each FID shall be transmitted at the *Transmit Period* defined using the *VDL Access Method* defined. If the most recently presented data is older than *Presentation Timeout* the associated ASM shall not be transmitted.

The ITDMA access scheme is suited to periodic transmissions of less than approximately 7-minute interval. SOTDMA reservations are for single slot messages only, so are not used.

5.1.2 Operating mode

STEDS functionality is configured in the Operating mode screen, as shown in Figure 29

The screenshot displays the 'OPERATING MODE' screen. At the top, there is a status bar with 'UTC' on the left, 'SOG -' and 'COG -' in the middle, and navigation icons (up/down arrows, signal strength, 'S2', a crossed-out gear, an exclamation mark, and an envelope) on the right. Below the status bar, the screen is titled 'OPERATING MODE' on the left and 'NO GNSS' on the right. The main content area is titled 'Select operating mode' and contains two radio button options: 'SOLAS' (selected) and 'Non-SOLAS'. Below this, there are four configuration fields: 'STEDS mode' set to 'Normal', 'Type of AIS' set to 'Vessel', 'Class B filter' set to 'No filter', and 'Unit type' set to '0'.

Figure 29 Operating mode screen

The following features are supported:

- STEDS mode - as detailed in the previous section
- Class B filter - allows Class B vessels to be filtered out
- Type of AIS - select between vessel and aircraft EAIS asset types.
- Unit type - enter a numerical value to select the relevant EAIS unit type. The EAIS unit type list is provided in Table 9 for reference.

#	Type	STEDS ABBREVIATION
USCG - CUTTERS		(max. 5 characters)
1	USCG 418' WMSL	WMSL
2	USCG 360' WMSM	WMSM
3	USCG 154' WPC	WPC
4	USCG 420' WAGB	WAGB
5	USCG 399' WAGB	WAGB
6	USCG 378' WHEC	WHEC
7	USCG 240' WLBB	WLBB
8	USCG 295' WIX	WIX
9	USCG 282' WMEC	WMEC
10	USCG 270' WMEC	WMEC
11	USCG 225' WLB	WLB
12	USCG 213' WMEC (Decommissioned)	WMEC
13	USCG 210' WMEC	WMEC
14	USCG 175' WLM	WLM
15	USCG 179' WPC	WPC
16	USCG 160' WLIC	WLIC
17	USCG 100' WLIC	WLIC

#	Type	STEDS ABBREVIATION
18	USCG 75' WLIC	WLIC
19	USCG 140' WTGB	WTGB
20	USCG 110' WPB	WPB
21	USCG 100' WLI	WLI
22	USCG 65' WLI	WLI
23	USCG 75' WLR	WLR
24	USCG 65' WLR	WLR
25	USCG 65' WYTL	WYTL
26	USCG 87' WPB	WPB
27	USCG [TBD] WCC	WCC
28	USCG 460' WMSP	WMSP
29-49	Reserved for future CG cutter types	
USCG - BOATS		
50	Short Range Prosecutor	SRP
51	Long Range Interceptor	LRI
52	USCG ANB	ANB
53	USCG ATB	ATB
54	USCG ASB	ASB
55	USCG BU	BU
56	USCG BUSL	BUSL

#	Type	STEDS ABBREVIATION
57	USCG CB-L	CB-L
58	USCG CB-M	CB-M
59	USCG CB-S	CB-S
60	USCG MLB	MLB
61	USCG MSB	MSB
62	USCG RB-HS	RB-HS
63	USCG RB-S	RB-S
64	USCG TANB	TANB
65	USCG UTB	UTB
66	USCG UTL	UTL
67	USCG UTM	UTM
68	USCG CB-OTH	CBOTH
69	USCG TPSB	TPSB
70	Special Purpose Craft - Law Enforcement	SPC-LE
71	Special Purpose Craft - Heavy Weather	SPC-HWX
72	Special Purpose Craft - Shallow Water	SPC-SW
73	Special Purpose Craft - Nearshore Life-boat	SPC-NLB
74	Special Purpose Craft - AIR	SPC-AIR
75	USCG-CB-ATON-L	CB-ATON-L

#	Type	STEDS ABBREVIATION
76	USCG RB-S II	RB-S II
77	Special Purpose Craft - Boarding Team	SPC-BTD
78	Special Purpose Craft - Training Boat	SPC-TB
79	USCG RB-M	RB-M
80	USCG CB-ATON-M	CB-ATON-M
81	Special Purpose Craft - Screening Vessel	SPC-CV
82	Over The Horizon - Cutter Boat	OTH-CB
83 - 99	Reserved for future CG boat types	
USCG - AIRCRAFT		
100	Vertical takeoff Unmanned Aerial Vehicle	VUAV
101	High Altitude Endurance Unmanned Aerial	HAE-UAV
102	USCG HC-130H	HC130H
103	USCG HC-130J	HC130J
104	USCG HU-25A (Decommissioned)	HU25A
105	USCG HU-25B (Decommissioned)	HU25B
106	USCG HU-25C (Decommissioned)	HU25C
107	USCG HC-144A	HC144A
108	USCG HH-60	HH60
109	USCG MH-60	MH60

#	Type	STEDS ABBREVIATION
110	USCG HH-65C	HH65C
111	USCG MH-65C	MH65C
112	USCG MH-68A (Decommissioned)	MH68A
113-129	Reserved for future CG aircraft types	
USCG - OTHER		
130	Boarding Team	CGBT
131	Patrol from shore	CGSP
132	Mobile Team	CGMT
133	NAIS Base Station	CGNBS
134-199	Reserved for future CG asset types	
OTHER GOVERNMENT AGENCIES		
200	Navy: Ship	
201	Navy: Boat	
202	Navy: Submarine	
203	Navy: Helicopter	
204	Navy: Fix-Wing	
205	Navy: UAV	
206	Military Sealift Command (MSC): Ship	
207	Military Sealift Command (MSC): Boat	
208	DOD - Other: UAV	

#	Type	STEDS ABBREVIATION
209	DOD - Other: Fix-Wing	
210	DOD - Other: Helicopter	
211	DOD - Other: Boat	
212	Customs & Border Protection (CBP): Boat	
213	Customs & Border Protection (CBP): Helicopter	
214	Customs & Border Protection (CBP): Fix-Wing	
215	Federal Law Enforcement: Boat	
216	Federal Law Enforcement: Helicopter	
217	Federal Law Enforcement: Fix-Wing	
218	Federal Agency - Other: Ship	
219	Federal Agency - Other: Boat	
220	Federal Agency - Other: Helicopter	
221	Federal Agency - Other: Fix-Wing	
222	Coast Guard Auxiliary: Boat	
223	Coast Guard Auxiliary: Fix-Wing	
224	Air Force Auxiliary: Fix-Wing	
225	State Police: Boat	
226	State Police: Helicopter	

#	Type	STEDS ABBREVIATION
227	State Agency - Other: Boat	
228	State Agency - Other: Helicopter	
229	Local Police: Boat	
230	Local Police: Helicopter	
231	Local Fire/Rescue: Boat	
232	Local Agency - Other: Boat	
233	Local Agency - Other Helicopter	
234-299	Reserved for future OGA asset types	
300-1021	Reserved for future use	

Table 9 EAIS Asset type list

5.2 STEDS Presentation interface

5.2.1 Operating mode configuration and reporting

The STEDS operating mode may be set by any of the following means:

- "PUCG,STEDS proprietary sentence on the NMEA 0183 PI
- "PGN# 65535 on the NMEA 2000 PI

The following means are supported also for compatibility with legacy systems:

- "PL3A,STEDS proprietary sentence on the NMEA 0183 PI
- "PGN# 65534 on the NMEA 2000 PI

The current STEDS operating mode is reported via the PI periodically using the sentence and PGN report. If an explicit query is presented using the legacy sentence or PGN, then the query response shall use the legacy form.

5.2.2 EAIS message transmission

In *Normal Transmit* and *Restricted Transmit* modes transmission of EAIS messages requires the appropriate ASM requests to be presented to the AIS as defined in Table 8. ASM requests may be presented in the following manner:

- "ABM or BBM sentence on the NMEA 0183 PI
- "PGN# 126208 Command Group Function

In addition, when the EAIS legacy mode is enabled, binary message PGN#'s 129796, 129797, 129811, and 129812 on the NMEA 2000 PI shall be interpreted as a transmission request equivalent to an ABM / BBM request.

5.2.3 EAIS message receive

All received broadcast or own-vessel addressed binary messages are output on the PI without interpretation by the AIS transceiver.

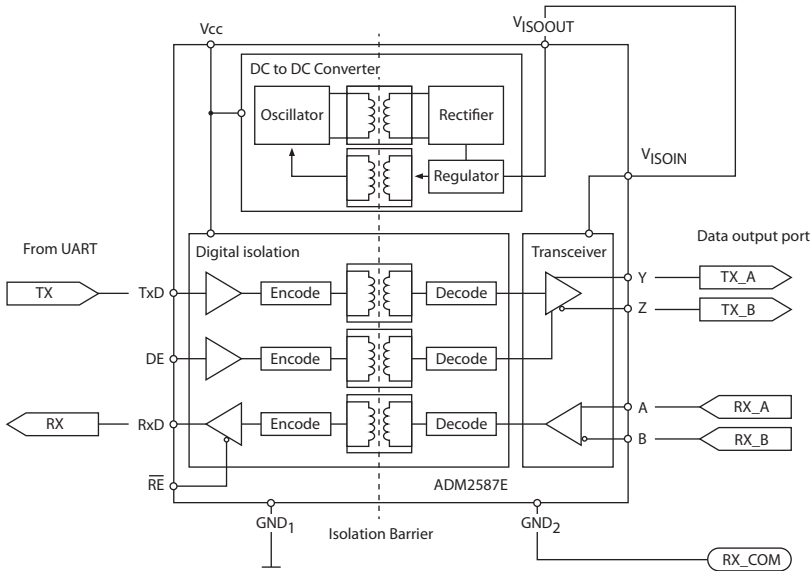

Figure 31 Data output port schematic



Each bi-directional data port is isolated from the other bi-directional data ports and from the AIS transceiver's internal power supply.

6.2 Output drive capability of bi-directional ports

Bi-directional ports can supply an output current of up to 30mA. The output voltages are 0 (low) and 3.3V (high). Effective load resistance should be in excess of 100 Ohms.

6.3 DGNSS Port

The DGNSS correction port is intended for connection to a beacon receiver. The port has the same physical characteristics as the bi-directional data ports as described in the preceding sections. If connection of a beacon receiver is not required this port can be re-configured as an additional bi-directional port to IEC 61162-2.

6.4 Input data sentence formats

All data input is via IEC 61162 / NMEA 0183 sentences. For details of the sentences and their checksums please refer to IEC 61162-1.

6.5 AIS Transceiver overall dimensions

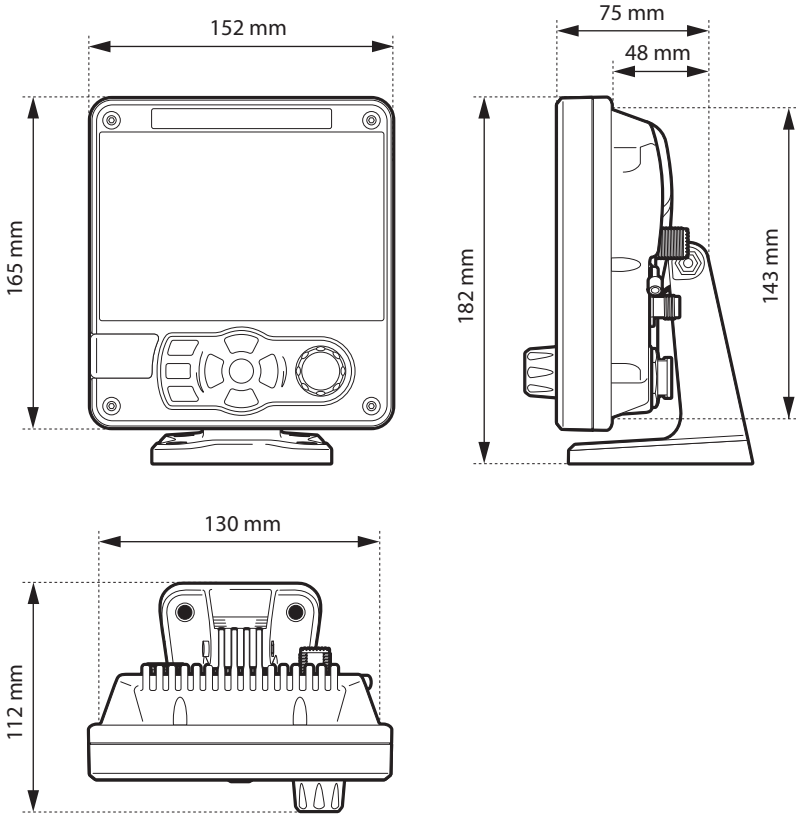

Figure 32 AIS Transceiver dimensions

6.6 GNSS Antenna drawing

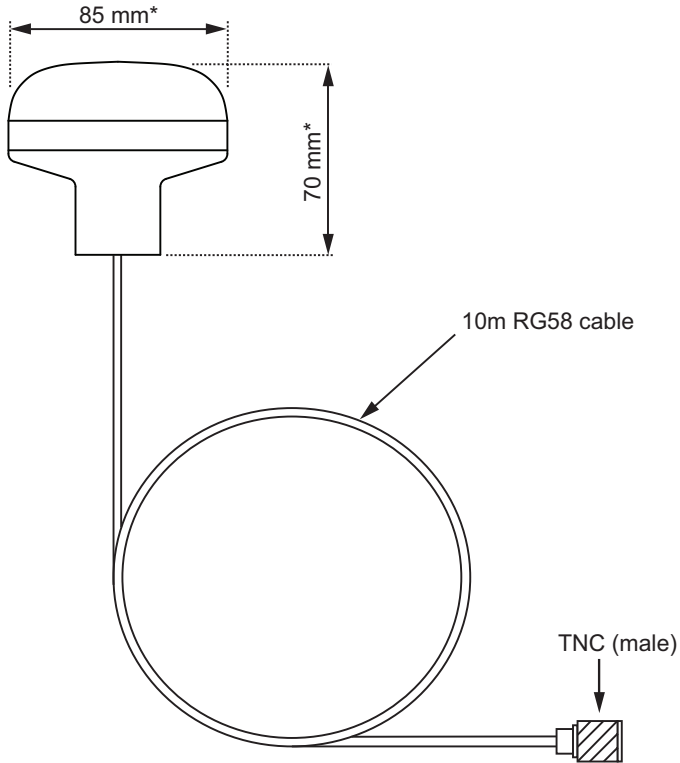

Figure 33 GNSS Antenna

* The dimensions of the supplied antenna may vary from those shown here.

6.7 Transmission intervals

The IEC 61162 sentences are in general output in response to a specific event, such as initiation of a binary message via the user interface. Certain messages are output over the ports at regular transmission intervals. Table 10. lists each sentence type and the transmission interval.

Output sentence type	Transmission interval	Comments
VDO	Once a second	Own vessel VDL reports. A 'dummy' VDO is generated every second. A transmission VDO is generated whenever the transceiver transmits a message.
ALC	Once every thirty seconds	The cycle alert list (ALC) sentence provides a list of all alerts that are not in alert state normal. When all alerts are in alert state normal, the number of alert entries will be zero.
ALR (inactive)	Once a minute	If no alerts are active, a single empty ALR sentence is output
ALR (active)	Once every thirty seconds	If any alerts are active, an ALR sentence is output for each active alert.
ABK, ACA, ALF, LR1, LR2, LR3, LRF, LRI, TXT, VDM	Only transmitted when specifically initiated by an external event	

Table 10 IEC 61162 Transmission interval for periodic sentences

6.8 Interface sentences

The IEC 61162 sentences accepted by and output by the AIS transceiver serial data ports are listed in Table 11.

Data port	Input sentences	Output sentences
Sensor 1 Sensor 2 Sensor 3	DTM, GBS, GGA, GLL, GNS, HDT, RMC, ROT, THS, VBW, VTG	N/A
External Display External Display 2* Pilot	ABM, ACA, ACK, ACN, AIR, BBM, DTM, EPV, GBS, GGA, GLL, GNS, HDT, RMC, ROT, SPW, SSA, SSD, THS, VBW, VSD, VTG, Proprietary: PUCG,STEDS PL3A,STEDS	ABK, ACA,ACS, ALC, ALF, ALR, ARC, EPV, NAK, SSD, TRL, TXT, VDM, VDO, VER, VSD Proprietary: PUCG,STEDS PL3A,STEDS
Long-range	LRF, LRI,	LR1, LR2, LR3, LRF, LRI,
DGNSS	RTCM SC-104 binary format	RTCM SC-104 binary format from received AIS message 17.

*External Display 2 / Long-range / DGNSS interfaces use the same port. Please select the required interface in the Interface menu.

Table 11 IEC 61162 Sentences input and output

The default SSA key is ABCDZX. Please contact your dealer if you wish to change it.

6.8.1 Legacy sentences

AIS alerts are now provided using the Bridge Alert Management requirements. However, in order to main compatibility with legacy systems, the ALR

sentence continues to be supported. The details of the supported alerts are shown in Table 12.

Alerts	Description
TX Malfunction	<p>This alert will occur if the MMSI has not been configured.</p> <p>This alert can also occur if the radio hardware has failed to select the correct frequency, that the output power is too low or a transmitter shutdown has occurred. In this situation, ALR 001 is output over the PI.</p> <p>The alert will be cleared if the transmitter recovers normal operation.</p>
RX Channel x malfunction	<p>This alert occurs should the receiver hardware malfunction. The receiver is identified by the value of x (as shown below). The following alerts will be generated over the PI in this condition:</p> <ul style="list-style-type: none">ALR 003 - Rx Channel 1ALR 004 - Rx Channel 2ALR 005 - DSC (Channel 70) <p>If the receiver returns to normal operation this alert will be cleared.</p>
VHF Antenna VSWR exceeds limit	<p>This alert occurs if there is a problem with your antenna or antenna connection.</p>
External EPFS lost	<p>This alert occurs if the position from the external Electronic Position Fixing System (i.e. GNSS) is invalid or lost.</p>

Alerts	Description
No valid COG information	This alert occurs if the AIS transceiver has no valid Course Over Ground information from any connected sensor.
No valid SOG information	This alert occurs if the AIS transceiver has no valid Speed Over Ground information from any connected sensor.
Heading lost or invalid	This alert occurs if the AIS transceiver has no valid heading information from any connected sensor, or if the heading is undefined.
No valid ROT information	This alert occurs if the AIS transceiver has no Rate Of Turn information from connected sensors or via internal calculation.
No sensor position in use	This alert occurs if the AIS transceiver has no valid position information from any connected sensor.
UTC Sync Invalid	This alert indicates that the transmitter is no longer directly synchronized with the GNSS receiver. This may be because the GNSS receiver cannot receive sufficient satellites.
Nav Status Incorrect	<p>Nav Status incorrect</p> <p>This alert will occur if the navigation status is in conflict with the current speed of the vessel. For example the alert will activate if the Navigation status is set to moored, but the vessel speed is greater than 3 knots. Correct the navigation status to clear this alert.</p>

Alerts	Description
Active AIS SART	An active AIS SART (AIS Search and Rescue Transmitter) message has been received. The SART will be displayed as the top item in the target list. Select this item to see the location of the SART.
Internal / External GNSS mismatch	This alert occurs if the difference in position reported by the internal and external GNSS receivers is too large. Check the vessel dimensions and GNSS antenna locations have been entered correctly.
Heading sensor offset	This alert occurs if the difference between the course over ground and heading data is greater than 45° for more than 5 minutes. This alarm only occurs if the vessel speed over ground is greater than 5 knots.

Table 12 ALR Alerts

6.9 Unused fields

Unused fields in the sentences from section 6.8 are listed in Table 13. All fields of other input and output sentences that are not in this table are used.

Sentence	Unused fields	Description
AIR	9 10 11 12	Channel of Interrogation Message ID 1.1 Station 1 reply slot Message ID 1.2 Station 1 reply slot Message ID 2.1 Station 2 reply slot
DTM	2 3 5 7	Local datum subdivision code Lat offset, min, N/S Longitude offset, min, E/W Altitude offset, (meter)
GBS	4 5 6 7 8	Expected error in altitude ID of most likely failed satellite Probability of missed detection for most likely failed satellite Estimate of bias on most likely failed satellite Standard deviation of bias estimate
GGA	5 6 7 8 9 10 11 12	No. of satellites in use, 00-12 Horizontal dilution of precision Antenna altitude above / below mean sea level (geoid) Units of antenna altitude, m Geoidal separation Units of geoidal separation, m Age of diff. GPS data Differential reference station ID 0000-1023

Sentence	Unused fields	Description
GNS	5 6 7 8 9 10	Number of satellites in use, 00-99 Horizontal dilution of precision Antenna altitude, m, above mean sea-level Geoidal separation, m Age of differential data Differential reference station ID
RMC	7 8	Date: dd/mm/yy Magnetic variation, degrees, E/W
VBW	1 2 3 7 8 9 10	Longitudinal water speed, knots Transverse water speed, knots Status: water speed Stern transverse water speed, knots Status: stern water speed Stern transverse ground speed Status: stern ground speed
VTG	2	Course over ground, degrees magnetic

Table 13 Unused fields

6.10 Proprietary sentences

The AIS transceiver outputs no proprietary sentences in normal operation.

6.11 Priority of sensor ports

The AIS transceiver automatically assigns a priority scheme to connected sensors. Data from the highest priority sensor will always be used. Sensor input priority is for:

- Position
- COG+SOG

- Heading
- Rate of Turn

The sensor input ports have a priority order as shown in Table 14.

Port	Priority (1 = highest)
Sensor 1	1
Sensor 2	2
Sensor 3	3
External Display	4
Pilot	5
Long-range	6

Table 14 Port priority order

6.11.1 Position priority scheme

Position information is taken from the highest priority source reporting DTM with WGS84 or datum override and RMC. If no RMC sentences are available, position shall be taken from the highest priority source reporting DTM with WGS84 or datum override and any one of:

- GGA
- GNS
- GLL

The following sentences are only processed if they are from the currently selected position source:

- RMC
- GGA
- GNS
- GLL

- GBS
- GRS
- GSA
- GSV
- GFA

When no position has been received on the selected port for 30 seconds, the port is deselected as a position source, and a new source selected as described above.

6.11.2 Course and Speed priority scheme

COG and SOG are taken from the highest priority source reporting any one of:

- RMC (with DTM=WGS84 or datum override)
- VTG
- VBW

VTG and VBW are only processed if they are from the currently selected COG & SOG source. When no COG+SOG has been received on the selected port for 30 seconds, the port shall be deselected as a COG+SOG source, and a new source selected as described above.

6.11.3 Heading priority scheme

Heading shall be taken from the highest priority sensor reporting any one of:

- HDT
- THS

HDT and THS are only processed if they are from the currently selected Heading source. When no heading has been received on the selected port for 30 seconds, the port shall be deselected as a heading source, and a new source selected as described above

6.11.4 Rate of Turn priority scheme

Rate of Turn shall be taken from the highest priority sensor reporting ROT. ROT shall only be processed if they are from the currently selected Rate of Turn source. When no Rate of Turn has been received on the selected port for 30 seconds, the port shall be deselected as a Rate of Turn source, and a new source selected as described above.

6.12 Compatibility mode

Some devices require the use of Compatibility mode for correct operation. When operating in the standard mode the fix quality flag indicates the type of GNSS position that is being reported. In compatibility mode, the fix quality reported will either be No GNSS or GNSS.

On the 'Home' > 'System settings' > 'Interfaces' screen, under the configuration menu for each sensor port there is an On / Off toggle which can be set if Compatibility mode is required for that port.

6.13 Message 24 content

The Unit Serial Number transmitted in AIS Message 24B, in response to a Message 15 request, is encoded as follows (note that these characters represent individual bits in the data):

www www yxxx xxxx xxxx

w = week (0 - 52)

y = years since 2014 (0 - 7)

x = incrementing number (0 - 2047)

6.14 NMEA 2000 PGN List

The PGN's listed in Table 15. are supported by the AIS transceiver. There are no unused fields.

PGN (Dec.)	PGN (Hex)	Title in NMEA database	Usage	NMEA 0183
059392	0E800	ISO Acknowledgment	in, out	
059904	0EA00	ISO Request	in, out	

PGN (Dec.)	PGN (Hex)	Title in NMEA database	Usage	NMEA 0183
060416	0EC00	ISO Transport Protocol - Data	in, out	
060160	0EB00	ISO Transport Protocol - Connection	in, out	
060928	0EE00	ISO Address Claim	in, out	
065240	0FED8	ISO Commanded Address	in	
065534	0FFFE	USCG Proprietary STEDS Configuration Command/Report	in, out	PUCG,STEDS
065535	0FFFF	USCG Proprietary STEDS Configuration Command/Report (legacy)	in, out	PUCG,STEDS
126208	1ED00	Group Function	in, out	
126464	1EE00	PGN list - Group Function	in, out	
126992	1F010	System time	out	
126993	1F011	Heartbeat	out	
126996	1F014	Product Information	in, out	
126998	1F016	Configuration Information	out	
127250	1F112	Vessel Heading	in	HDT/THS
127251	1F113	Rate of Turn	in	ROT

PGN (Dec.)	PGN (Hex)	Title in NMEA database	Usage	NMEA 0183
129025	1F801	GNSS Position (Rapid Update)	out	RMC
129026	1F802	GNSS Direction data	in, out	RMC
129029	1F805	GNSS Position data	in, out	RMC
129038	1F80E	AIS Class A Position Report	out	VDM/VDO
129039	1F80F	AIS Class B Position Report	out	VDM/VDO
129040	1F810	AIS Class B Extended Position Report	out	VDM/VDO
129041	1F811	AIS AtoN Report	out	VDM/VDO
129545	1FA090	GNSS RAIM	in	GBS
129793	1FB01	AIS UTC and Date Report	out	VDM/VDO
129794	1FB02	AIS Class A Static and Voyage Related Data	out	VDM/VDO
129795	1FB03	AIS Addressed Binary Message	in, out	VDO (out), ABM (in)
129796	1FB04	AIS Acknowledge	in, out	VDO (out) BBM (in)
129797	1FB05	AIS Binary Broadcast Message	out	VDM/VDO

PGN (Dec.)	PGN (Hex)	Title in NMEA database	Usage	NMEA 0183
129798	1FB06	AIS SAR Aircraft Position Report	out	VDM/VDO
129801	1FB09	AIS Addressed SRM	out	VDM/VDO
129802	1FB0A	AIS Safety Broadcast Binary Message	out	VDM/VDO
129809	1FB11	AIS Class B CS Static Data Report Part A	out	VDM/VDO
129810	1FB12	AIS Class B CS Static Data Report Part B	out	VDM/VDO
129811	1FB13	AIS Single-Slot Binary Message	in, out	VDO (out), ABM/BBM (in)
129812	1FB14	AIS Multi-Slot Binary Message	in, out	VDO (out), ABM/BBM (in)

Table 15 PGN List

6.15 Troubleshooting

Issues	Possible cause and remedy
No data is being received by a connected chart plotter	<ul style="list-style-type: none"> ● Check that the power supply is connected correctly. ● Check that the power supply is a 12VDC or 24VDC supply. ● Check that the connections to the chart plotter are correct.
The screen is not illuminated	<ul style="list-style-type: none"> ● Check that the power supply is connected correctly. ● Check that the power supply is a 12VDC or 24VDC supply. ● Press and hold the '<i>Navigation status / Screen brightness</i>' button for at least 5 second. The display should return to maximum brightness.

<p>The 'Alert' icon is illuminated or flashing</p>	<ul style="list-style-type: none">• The unit may not have a valid MMSI. Check that the AIS transceiver is correctly configured with a valid MMSI.• The VHF antenna may be faulty. Please check the connection to the VHF antenna and that the VHF antenna is not damaged. The alarm icon may illuminate briefly if the VHF antenna characteristics are briefly affected.• No GNSS position fix can be obtained. Please check the AIS transceiver is located where the internal GNSS antenna has a clear sky view or that an external GNSS antenna is properly connected and installed. Review the GNSS signal strength graph in <i>'Home' > 'System settings' > 'Advanced' > 'GNSS Source'</i>.• The power supply is outside the allowable range. Check that the power supply is within the range 10.8VDC to 31.2VDC• Check for the alert messages in the <i>'Alerts'</i> menu and check the help available.• If none of the above correct the alert condition please contact your dealer for advice.
--	---

<p>External Sensors not being recognised.</p>	<ul style="list-style-type: none"> ● Check Compatibility Mode option in the Interface Settings Menu. ● Check the Baud Rate set. ● Check the wiring is correct.
<p>VSWR Alert Activated or High VSWR.</p>	<ul style="list-style-type: none"> ● Ensure VHF Antenna is as far away as possible from metallic structures and any other antennae. ● Ensure VHF Antenna is as high as possible. ● Ensure VHF Antenna is suitable for AIS i.e. 3dBi Gain, 156-162MHz, and uses high quality RG213 or RG214 cable. ● The VHF Antenna cable should be as short as possible and no more than 30 metres (100ft) in length.

Table 16 Troubleshooting

If the guidance given in the table above does not rectify the problem you are experiencing, please contact your dealer for further assistance.

7 Junction box accessory

The Junction Box is an optional accessory which facilitates connection of the AIS transceiver to a range of external systems and sensors.

7.1 What's in the box

Please ensure all items are present and if any of the items are missing please contact your dealer.

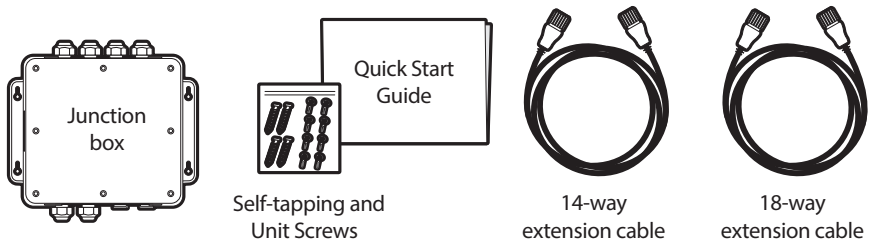

Figure 34 Junction box - What's in the box

7.2 Installation

The junction box should be mounted within 2m of the AIS transceiver, to ensure that the cable can be run without compromising its performance.

- Connect the two extension cables between the AIS transceiver and the junction box.
- Route your accessory cables through the waterproof cable glands and find the appropriate terminal blocks to fix them to.
- Use the connector wiring diagrams shown in Figure 11. and Figure 14. as your guide.
- Secure the ground / screen / shield of the accessory cables to the metallic strips of the junction box or to the appropriate connection on the terminal block.

- The termination jumpers are there to ensure correct 120 Ohm termination to the serial ports. These will all be fitted by default but if a port requires no termination then that port's jumper can be removed.
- Secure the accessory cables within the junction box with cable ties (not supplied).
- Refit the lid securely using the 8 screws provided to ensure the waterproof integrity of the unit.

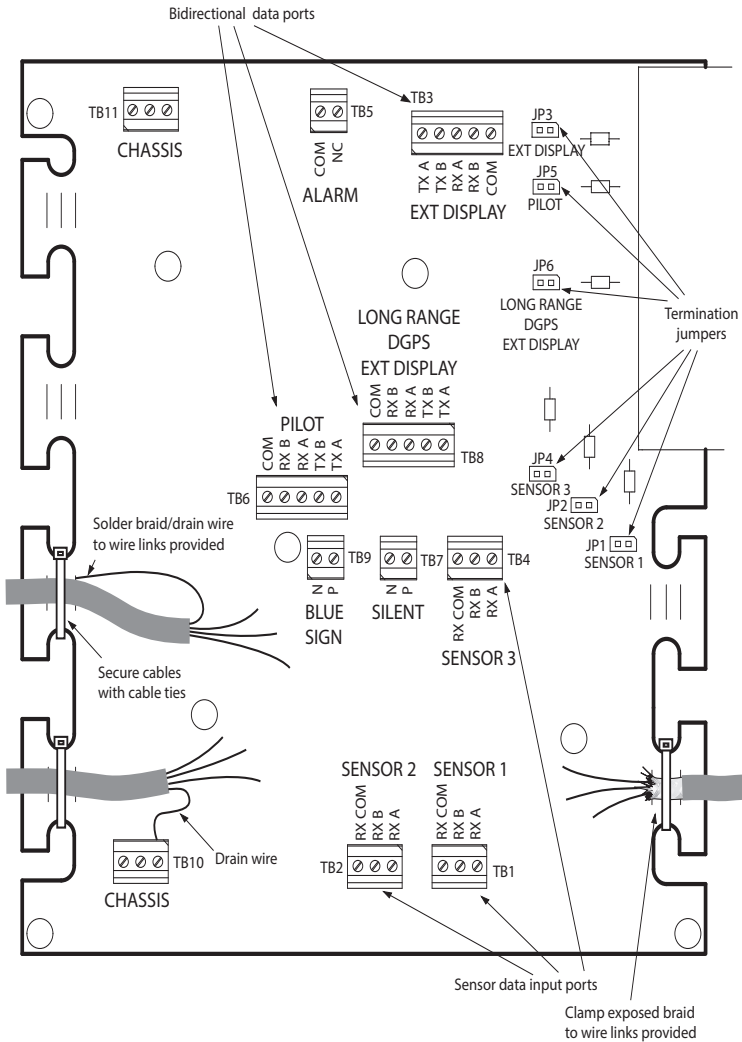

Figure 35 Junction box connections

7.3 Connecting external equipment

- Figure 36. shows an example of how external equipment could be connected through the junction box accessory.

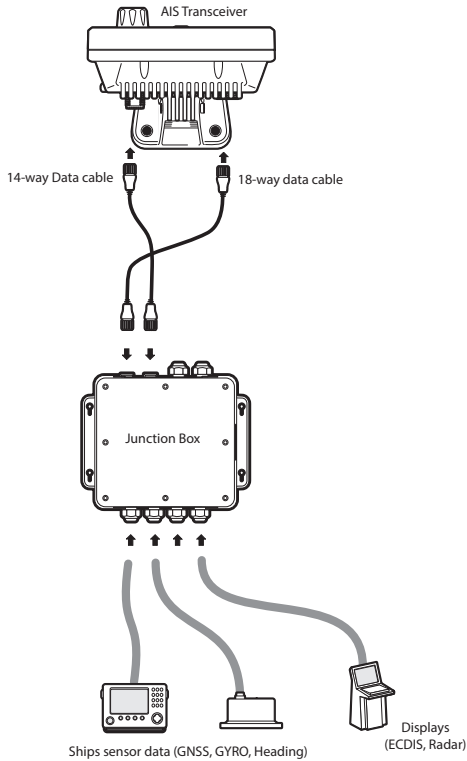

Figure 36 Connecting external equipment

When connecting external equipment the following procedures should be observed.

- The common line should be connected to the sensor port if one is available.

- The shield in the cable used to connect the external equipment should be connected at one end only. Refer to the manufacturer's documentation regarding cable construction.
- The chassis connection can be made with **EITHER** a drain wire **OR** directly to the cable shield using exposed wire links on the junction box printed circuit board, depending on the cable construction.

7.4 Technical information

7.4.1 Physical

Junction box dimensions	235mm x 69mm x 233mm (WxHxD)
Junction box weight	0.65kg

7.4.2 Environmental

Operating temperature range	-25°C to +55°C tested to IEC 60945 'Exposed' category
Maximum operating humidity	90% at +40°C, non-condensing
Water ingress rating	IPx6

7.4.3 Data Connector Information

18-way data connector	Chogori 23018525-04-RC	Mating half	Chogori 23018221-01
14-way data connector	Chogori 23014525-05-RC	Mating half	Chogori 23014221-01

8 Technical specification

8.1 Assessed requirements

8.1.1 Implementing Regulation (EU)2020/1170

8.1.2 Compliance Requirements for MED/4.32

IMO resolutions	International Testing Standards	
IMO Res. A.694(17)	IEC 60945 (2002) incl. IEC 60945 Corr. 1(2008)	Maritime navigation and radio communication equipment and systems - General requirements
	IEC61162-1 (2016)	Maritime navigation and radio communication equipment and systems – Digital interfaces Part 1: Single talker and multiple listeners
	IEC 61162-2 (1998)	Maritime navigation and radio communication equipment and systems – Digital interfaces Part 2: Single talker and multiple listeners, high-speed transmission
	IEC 61162-3 (2008) + A2 (2014)	Maritime navigation and radio communication equipment and systems – Digital interfaces Part 3: Serial data instrument network

<p>IMO Res. MSC.74(69) ITU-R M.1371-5 (2014)</p>	<p>IEC 61993-2 (2018)</p>	<p>Maritime navigation and radio communication equipment and systems – Automatic Identification System (AIS) Part 2: Class A shipborne equipment of the universal automatic identification system (AIS)</p>
<p>IMO Res. MSC.191(79))</p>	<p>EC 62288 (2014)</p>	<p>Maritime navigation and radio communication equipment and systems – Presentation of navigation- related information on shipborne navigational displays</p>
<p>IMO Res. MSC.302(87))</p>	<p>IEC 62923-1 (2018)</p>	<p>Maritime navigation and radio communication equipment and systems – Bridge alert management Part 1: Operational and performance requirements, methods of testing and required test results</p>
	<p>IEC 62923-2 (2018)</p>	<p>Maritime navigation and radio communication equipment and systems – Bridge alert management Part 2: Alert and cluster identifiers and other additional features</p>

8.2 Product category

<p>Product category</p>	<p>This product is categorised as ‘exposed’ in accordance with the definitions provided in IEC 60945</p>
-------------------------	--

8.3 Physical

AIS Transceiver dimensions	152mm x 165mm x 111mm (WxHxD), see Figure 32. for drawing)
AIS Transceiver weight	1.5kg
Compass safe distance	0.5m (AIS Transceiver)
Safe operating distance	20cm from the antenna

8.4 Environmental

Operating temperature range	-25°C to +55°C tested to IEC60945 'Exposed' category
Maximum operating humidity	90% at +40°C, non-condensing
Water ingress rating	IPx6, IPx7

8.5 Electrical

Supply voltage	12VDC to 24VDC (absolute min 10.8V, absolute max 31.2 V)
Power consumption	6.2W (average)
Current consumption @12 VDC supply	0.65A typical, 4.3A peak
Current consumption @24 VDC supply	0.36A typical, 2.2A peak

8.6 Display and user interface

Display	800 x 480 pixel colour LCD with adjustable backlight
Luminance	500cd/m ² max, 75cd/m ² default <0.5cd/m ² min
Recommended viewing distance	45cm
Display visibility	visible while wearing glasses / sunglasses with polarized lenses.

Keypad	Five function keys and three menu keys with adjustable backlight
Rotary control	Encoder with push function
Speaker	600mW@750Hz 11mm x 15mm

8.7 Internal GNSS

Receiver channels	72 channels GPS, GLONASS and Beidou operating modes
Time to first fix	Typically 26 seconds
Frequency	L1 GPS band 1575.42MHz L1 GLONASS band 1597.1 - 1609.5MHz B1 BeiDou band 1561.098MHz
Accuracy	2.5m CEP / 5.0m SEP without differential correction 2.0m CEP / 3.0m SEP with SBAS or RTCM GNSS correction
Antenna requirement	Active antenna (5V bias) with gain >15dB

8.8 TDMA Transmitter

Frequency range	156.025MHz to 162.025MHz
Channel bandwidth	25kHz
Output power	1W or 12.5W (automatic selection)
Data transmission rate	9600 bits/s
Modulation mode	25kHz GMSK

8.9 TDMA Receiver

Number of receivers	2
Frequency range	156.025MHz to 162.025MHz
Channel bandwidth	25kHz
Sensitivity	<-107dBm for 20% PER

Modulation mode	25kHz GMSK
Adjacent channel selectivity	70dB
Spurious response rejection	70dB

8.10 DSC Receiver

Number of receivers	1
Frequency	156.525MHz (Channel 70)
Channel bandwidth	25kHz
Sensitivity	-107dBm @ BER 10^{-2}
Modulation mode	25kHz AFSK
Adjacent channel selectivity	70dB
Spurious response rejection	70dB

8.11 RF Connections

VHF Antenna connection	SO-239 / UHF
VHF Port impedance	50 Ohms
GNSS Antenna connections	TNC female
GNSS Port impedance	50 Ohms

8.12 WiFi

Maximum output power IEEE 802.11g/n	+15dBm
Maximum output power IEEE 802.11b	+17dBm

8.13 Data interface

Sensor data input ports	
Number of ports	3
Standard	IEC 61162-1 / -2
Baud rate	4800 baud or 38400 baud
Port impedance	54K Ohms
Bi-directional data ports (including pilot port)	
Number of ports	3
Standard	IEC 61162-1 / -2
Baud rate	4800 or 38400 baud
Port impedance	54K Ohms
Differential correction port	
Standard	ITU 823-2 / RTCM SC-104
Baud rate	4800 baud or 38400 baud
Port impedance	54K Ohms
Blue Sign port	
Port impedance	10K Ohms

Silent Mode port	
Port impedance	10K Ohms
NMEA 2000 Port:	
Load equivalency number (LEN)	1

8.14 Power and data connector information

Power connector	Chogori 22002525-04-RC	Mating Half	Chogori 22002221-01
18-way data connector	Chogori 23018525-04-RC	Mating Half	Chogori 23018221-01
14-way data connector	Chogori 23014525-05-RC	Mating Half	Chogori 23014221-01

8.15 Open source licences

This product contains open source software. For details please see the 'System information' screen.

9 Installation record

The following installation record should be completed and retained on board the vessel once the AIS transceiver has been installed and commissioned.

9.1 Vessel details

Vessel name			
Flag state			
IMO Number		MMSI Number	
Owner		Radio call sign	
Type of vessel		Gross registered tonnage	
Length (m)		Beam (m)	
AIS Transceiver serial number			
Installation password			
Radio software version number			
MKD software version number			

External GNSS antenna location (all dimensions in meters, refer to diagram below)			
A=	B=	C=	D=

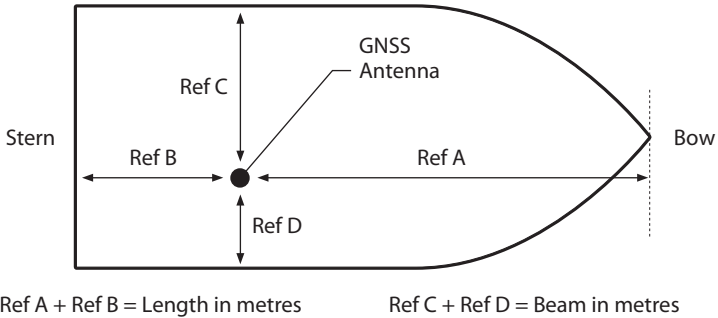

Figure 37 GNSS Antenna position

Connected equipment type (where applicable note equipment and AIS data port in each case).

(D)GPS Receiver	
Gyro compass	
ROT Indication	
Speed log	
ECDIS	
Radar	
Other equipment	
Power supply	

The following drawings should be provided and attached to this installation record.

- Antenna layout for VHF and GNSS antennas
- AIS arrangement drawing
- Block diagram showing interconnection of equipment

Maintenance Record

Modification record number	Details (enter details of modifications to the AIS transceiver including software updates)
1	
2	
3	
4	
5	
6	
7	
8	
9	
10	

Installer Detail

Installed by (name)	
Installation company name	
Date of installation	
Vessel location at installation	
Signature	



Raymarine

Marine House, Cartwright Drive, Fareham, Hampshire.
PO15 5RJ. United Kingdom.

Tel: +44 (0)1329 246 700

www.raymarine.com

Raymarine[®]

a brand by 

201-0907:5