

CLASSIC 310

SPECIFICATIONS

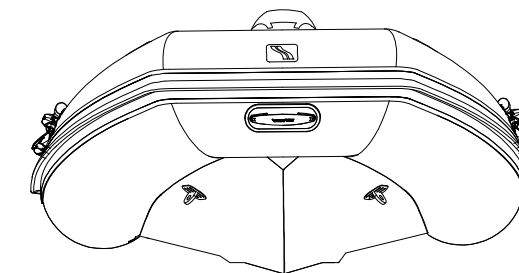
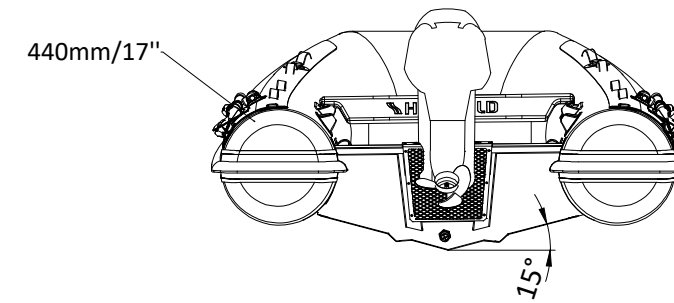
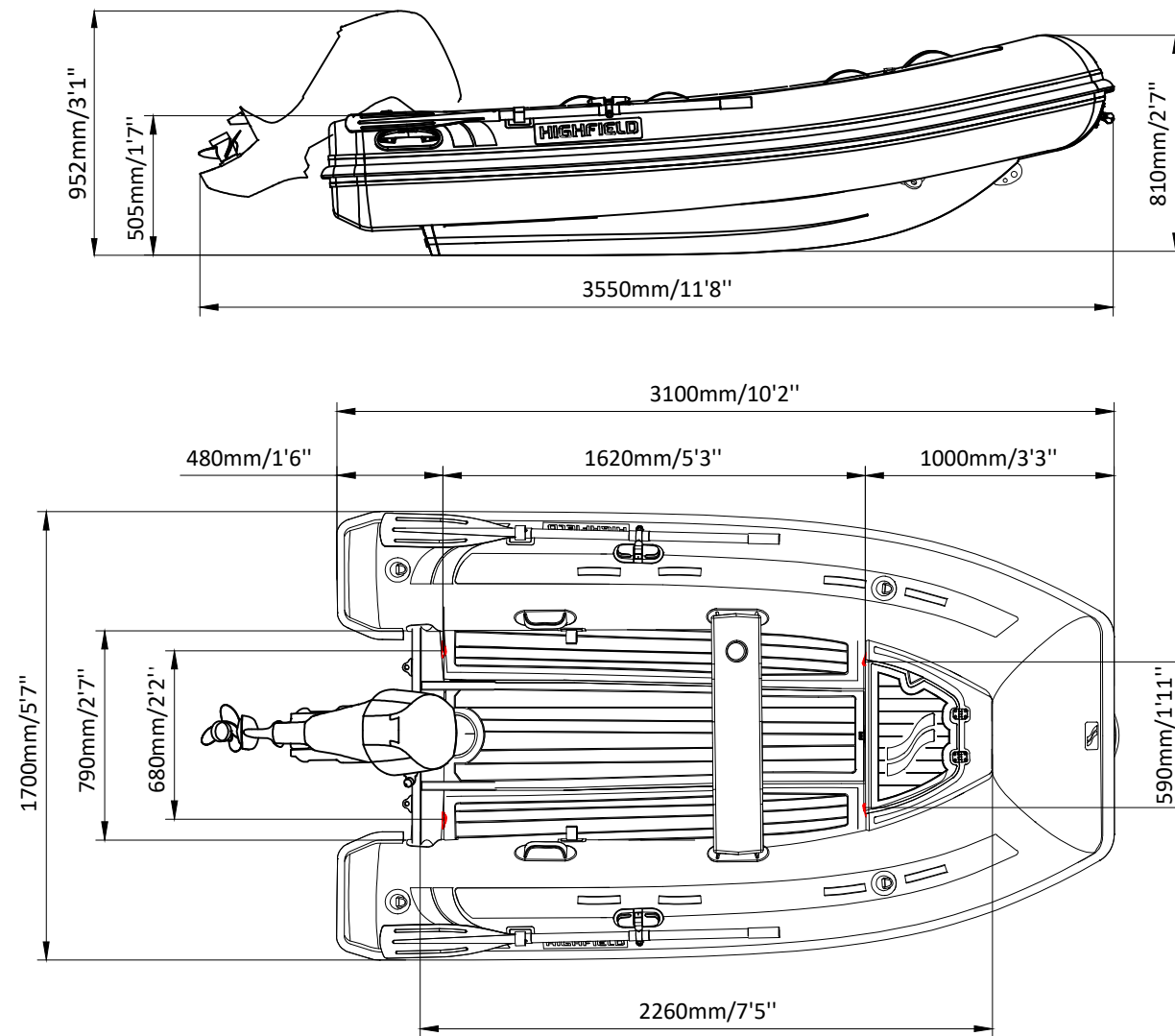

SPECIFICATIONS AND MAXIMUM CAPACITIES (Subject to change without notice. Tolerances: dimensions ±2.5%, weights ±5%)

MODEL	ISO 6185 PART	ISO 6185	Crew		#	Weight		Shaft	Outboard Engine		Molded seat		Oars		/		Fuel tank Capacity		Wet Weight (Approximate) 20HP (14.92KW)		AIR CHAMBERS	Pressure					
			KG	LB		KG	LB		KG	LB	KG	LB	KG	LB	KG	LB	L	GAL	KG	LB		PSI	BAR				
CL310	2	C	550	1213	5	375	827	S	14.92	20	104.5	230	62	137	3	6.6	1.5	3.3	/	/	/	/	171	377	3	3.63	0.25

Weight: boat only.

CLASSIC 310

SPECIFICATIONS

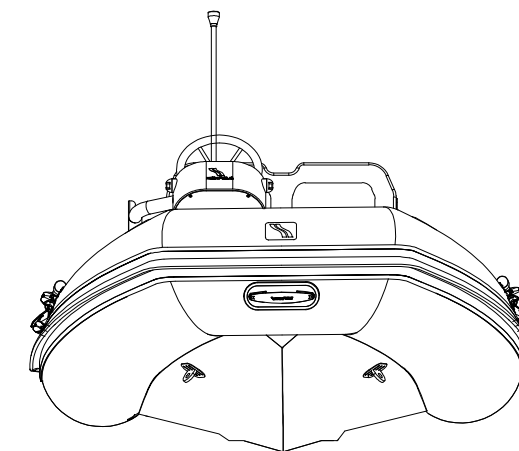
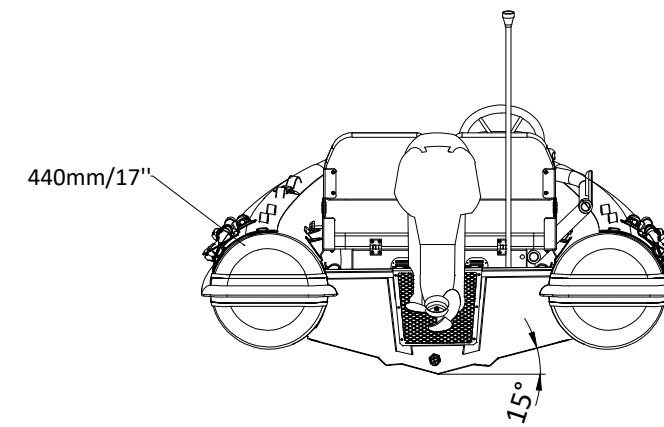
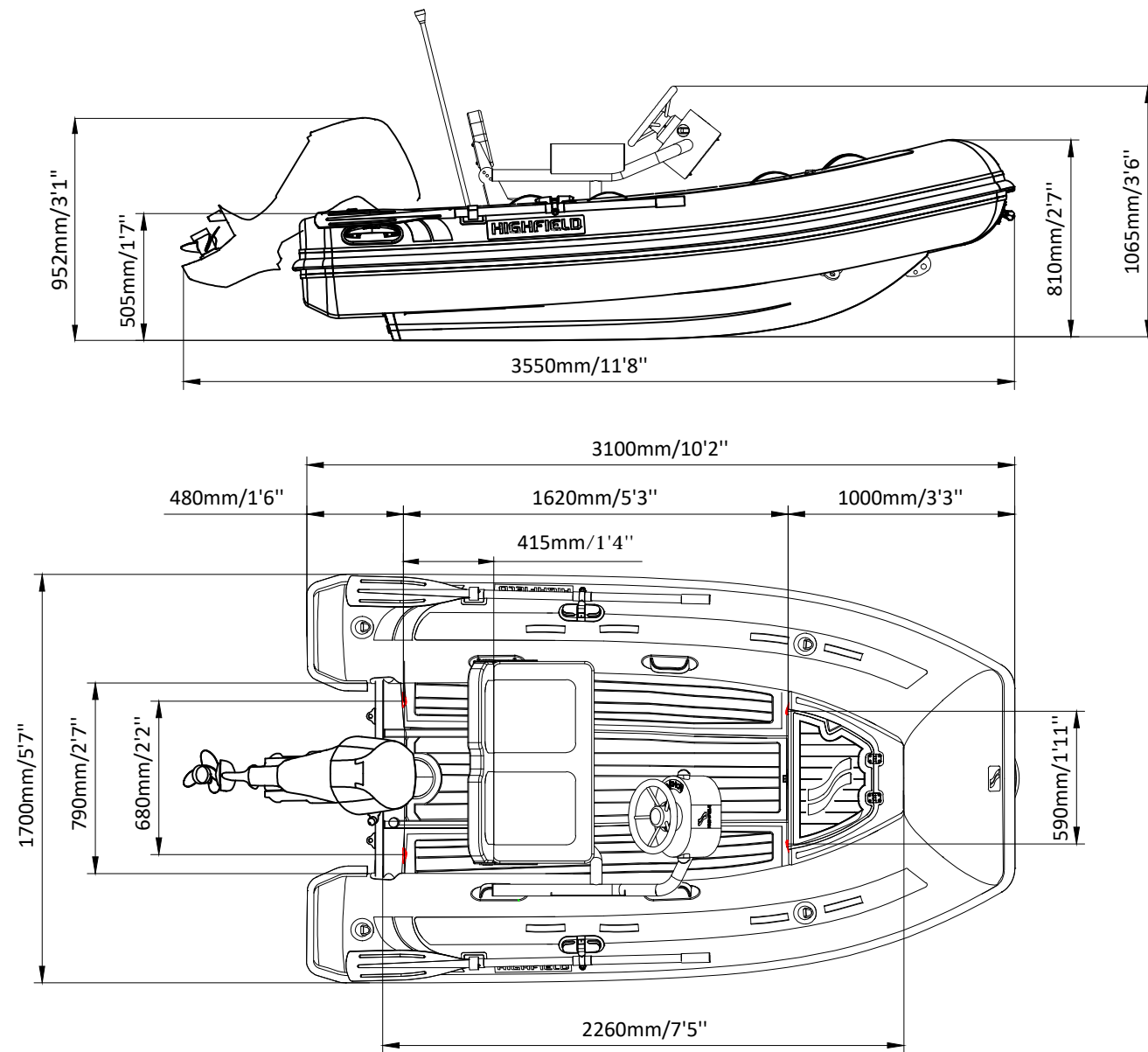

SPECIFICATIONS AND MAXIMUM CAPACITIES (Subject to change without notice. Tolerances: dimensions ±2.5%, weights ±5%)

MODEL	ISO 6185 PART	ISO 6185	Crew		#	Weight		Shaft	Outboard Engine		FCT		Molded seat		Oars		Fuel tank Capacity		Wet Weight (Approximate) 20HP (14.92KW)		AIR CHAMBERS	Pressure					
			KG	LB		KG	LB		KG	LB	KG	LB	KG	LB	KG	LB	L	GAL	KG	LB		PSI	BAR				
			Max power KW	Max power HP		Max weight KG	Max weight LB		KG	LB	KG	LB	KG	LB	KG	LB	KG	LB	KG	LB		PSI	BAR				
CL310	2	C	550	1213	5	375	827	S	14.92	20	104.5	230	62	137	36	79	3	6.6	1.5	3.3	/	/	207	456	3	3.63	0.25

Weight: boat only.