



MERCURY
GO BOLDLY.™

8M0231628 125 eng



**Operation
Maintenance
and
Installation
Manual**

150, 150 Pro XS, 150 SeaPro FourStroke

© 2025 Mercury Marine



Scan for service and support information

Welcome

You have selected one of the finest marine power packages available. It incorporates numerous design features to ensure operating ease and durability. With proper care and maintenance, you will enjoy using this product for many boating seasons. To ensure maximum performance and carefree use, we ask that you thoroughly read this manual before operating the outboard.

The Operation and Maintenance Manual contains specific instructions for using and maintaining your product. Keep this manual with the product for reference whenever you are on the water. This manual should stay with the outboard engine, if it is sold.

Thank you for purchasing one of our products. We sincerely hope your boating will be pleasant.

Mercury Marine, Fond du Lac, Wisconsin, U.S.A.

Read This Manual Thoroughly

IMPORTANT: Your dealer can provide a demonstration of starting and operating procedures. If you do not understand any portion of this manual, contact your dealer.

Safety Alerts

Throughout this publication and on your power package, safety alerts labeled

WARNING and CAUTION (accompanied by the symbol ) , are used to alert you to special instructions concerning a particular service or operation that may be hazardous if performed incorrectly or carelessly. Observe these alerts carefully.

These safety alerts alone cannot eliminate the hazards that they signal. Strict compliance to these special instructions when performing the service, plus common sense operation, are major accident prevention measures.

WARNING

Indicates a hazardous situation which, if not avoided, could result in death or serious injury.

CAUTION

Indicates a hazardous situation which, if not avoided, could result in minor or moderate injury.

Additional Alerts

Additional alerts provide information that requires special attention:

NOTICE

Indicates a situation which, if not avoided, could result in engine or major component failure.

IMPORTANT: Identifies information essential to the successful completion of the task.

NOTE: Indicates information that helps in the understanding of a particular step or action.

California Proposition 65

California Proposition 65



WARNING: This product can expose you to chemicals including gasoline engine exhaust, which is known to the State of California to cause cancer and birth defects or other reproductive harm. For more information go to www.P65Warnings.ca.gov.

Notice to Users of This Manual

IMPORTANT: The operator (driver) is responsible for the correct and safe operation of the boat, the equipment aboard, and the safety of all occupants aboard. The operator is strongly encouraged to read this Operation and Maintenance Manual to thoroughly understand the operational instructions for the power package and all related accessories before the boat is used.

Descriptions and specifications contained herein were in effect at the time this was approved for distribution. Mercury Marine, whose policies are based on continuous improvement, reserves the right to discontinue models at any time or to change specifications or designs without notice and without incurring obligation.

Warranty Message

The product you have purchased comes with a **Mercury Marine Limited Warranty**. The terms of the warranty are set forth in the Warranty Manual, which can be accessed any time on the Mercury Marine website, at <http://www.mercurymarine.com/warranty-manual>. The Warranty Manual contains a description of what is covered, what is not covered, the duration of coverage, how to best obtain warranty coverage, **important disclaimers, limitations, and waivers**, and other related information. Please review this important information.

Mercury Marine products are designed and manufactured to comply with our own high quality standards, applicable industry standards and regulations, and certain emissions regulations. At Mercury Marine every engine is operated and tested before it is boxed for shipment to make sure that the product is ready for use. In addition, certain Mercury Marine products are tested in a controlled and monitored environment, for up to 10 hours of engine run time, in order to verify and make a record of compliance with applicable standards and regulations. All Mercury Marine product, sold as new, receives the applicable limited warranty coverage, whether the engine participated in one of the test programs described above or not.

This manual contains information required for the safe and proper operation, installation, and maintenance of the product. Use of the product not in accordance with any and all instructions for operation and maintenance outlined in this manual will be considered as improper, abnormal, abusive or non-acceptable use of the product and may result in the Mercury Marine Limited Warranty or legal guarantee (if and where applicable) being fully or partly void.

Copyright and Trademark Information

© MERCURY MARINE. All rights reserved. Reproduction in whole or in part without permission is prohibited.

Alpha, Avator, Axius, Bravo One, Bravo Two, Bravo Three, Bravo Four S, Circle M with Waves Logo, GO BOLDLY, K-planes, Mariner, MerCathode, MerCruiser, Mercury, Mercury with Waves Logo, Mercury Marine, Mercury Precision Parts, Mercury Propellers, Mercury Racing, MotorGuide, OptiMax, Pro XS, Quicksilver, SeaCore, Skyhook, SmartCraft, Sport-Jet, Verado, VesselView, Zero Effort, Zeus, #1 On the Water and We're Driven to Win are registered trademarks of Brunswick Corporation. Mercury Product Protection is a registered service mark of Brunswick Corporation. All other marks are the property of their respective owners.

Important Safety Information

Boater's Responsibilities.....	1
Boat Horsepower Capacity.....	1
Exhaust Emissions.....	1
Outboard Mounting Notice.....	4
Outboard Remote Control Models	4
Lanyard Stop Switch.....	5
Staying Safe Around the Outboard.....	7
Safe Operating Practices.....	8
Impact with Underwater Hazards.....	13

General Information

Specifications.....	15
Component Identification.....	19
Propeller Selection.....	19
Recording Serial Number.....	20
Selecting Outboard Accessories.....	21

Outboard Installation

Important Installation Information.....	23
Mercury Marine Validated Engine Mounting Hardware.....	23
Transom Fastening Hardware.....	24
Accessories Mounted to the Transom Clamp Bracket.....	24
Fuel System.....	27
Transom Cutout and Mounting Holes.....	28
Checking Boat Transom Construction.....	32
Installing the Outboard.....	32
Steering Link Rod Installation.....	37
Rigging the Engine.....	38
Battery Cable Connections.....	47

Transporting

Aquatic Invasive Species (AIS).....	51
Trailing the Boat and Outboard.....	51

Fuel and Oil

Fuel Requirements.....	53
Fuel Additives.....	54
Fuel Demand Valve (FDV) Requirement.....	54
Fuel Tank.....	55
Low Permeation Fuel Hose Requirement	56
Quick-Disconnect Fuel Hose Fitting.....	57
Engine Oil Recommendations—Standard and Pro XS Models.....	57
Engine Oil Recommendations—SeaPro Models.....	58
Checking and Adding Engine Oil.....	59

Features and Controls

Remote Control Features.....	61
Warning System.....	61
Power Trim and Tilt.....	63
Trim Tab Adjustment.....	66

Operation

Engine Break-in Procedure.....	69
Important Daily Inspection Before Each Use	69
Prestarting Checklist.....	69
Starting the Engine.....	70
Gear Shifting.....	72
Stopping the Engine.....	73
Operating at High Elevations.....	73
Operating in Freezing Temperatures.....	73
Operating in Saltwater or Polluted Water.....	74
Operating in Shallow Water.....	74
Setting Trim Angle at Idle Speed.....	75
Fuel Supply Module Priming Procedure.....	75

Maintenance

EPA Emissions Regulations.....	79
Cleaning Care Recommendations.....	80
Top Cowl Removal and Installation.....	82
Inspection and Maintenance Schedule.....	83
Maintenance Schedule Decal (150 FourStroke).....	85
Battery Inspection	86
Flushing the Cooling System.....	86
Corrosion Control Anodes.....	87
Engine Oil and Filter.....	88
Fuel System.....	91
Gearcase Lubrication.....	93
Lubrication Points.....	95
Checking Power Trim Fluid.....	97
Propeller Replacement.....	97
Propeller Bore Sleeve Inspection—If Equipped	100
Spark Plug Inspection and Replacement.....	101
Transom Tightness Inspection.....	103

Storage

Storage Preparation.....	105
Protecting the Fuel System.....	105
Protecting External Outboard Components.....	105
Protecting Internal Engine Components.....	106
Gearcase.....	106
Positioning Outboard for Storage.....	106
Battery Storage.....	106

Troubleshooting

Effects of Elevation and Weather on Performance.....	109
Fuse Replacement.....	109
Starter Motor Will Not Crank the Engine.....	110
Engine Will Not Start.....	110
Engine Runs Erratically.....	111
Performance Loss.....	111
Battery Will Not Hold Charge.....	112
Submerged Outboard.....	112

Owner Service Assistance

Identification Records.....	113
Service Assistance.....	113
Ordering Literature.....	115

Maintenance Log

Maintenance Log.....	117
----------------------	-----

IMPORTANT SAFETY INFORMATION

Boater's Responsibilities

The operator (driver) is at all times responsible for the correct and safe operation of the boat and the safety of its occupants and the general public. Each operator should read and understand this entire manual before operating the outboard.

At least one additional person onboard should be instructed in the basics of starting and operating the outboard and boat handling, in case the driver is unable to operate the boat.

The operator may be subject to local boating license requirements, which may vary according to boating location.

Boat Horsepower Capacity

⚠ WARNING

Exceeding the boat's maximum horsepower rating can cause serious injury or death. Overpowering the boat can affect boat control and flotation characteristics or break the transom. Do not install an engine that exceeds the boat's maximum power rating.

Most boats have a capacity plate to indicate the maximum power and boat load, as determined by the manufacturer and based on federal guidelines and applicable regulations. Never exceed these maximums.

U.S. COAST GUARD CAPACITY	
MAXIMUM HORSEPOWER	XXX
MAXIMUM PERSON CAPACITY (POUNDS)	XXX
MAXIMUM WEIGHT CAPACITY	XXX

26777

For clarification of horsepower or loading restrictions, contact the boat dealer or the boat manufacturer.

Exhaust Emissions

⚠ WARNING

Inhaling engine exhaust gases can result in carbon monoxide poisoning, which can lead to unconsciousness, brain damage, or death. Avoid exposure to carbon monoxide.

Stay clear from exhaust areas when engine is running. Keep the boat well-ventilated while at rest or underway.

IMPORTANT SAFETY INFORMATION

Be Alert to Carbon Monoxide Poisoning

Carbon monoxide (CO) is a deadly gas that is present in the exhaust fumes of all internal combustion engines, including the engines that propel boats and the generators that power boat accessories. By itself, CO is odorless, colorless, and tasteless, but whenever engine exhaust can be tasted or smelled, CO is being inhaled.



Early symptoms of carbon monoxide poisoning—which are similar to the symptoms of seasickness and intoxication—include headache, dizziness, drowsiness, and nausea.

Boats with enclosed cabins should have one or more CO sensors installed.

Stay Clear of Exhaust Areas

Avoid areas of concentrated engine exhaust gases. When engines are running, keep swimmers away from the boat, and do not sit, lie, or stand on swim platforms or boarding ladders. While underway, do not allow anyone to be positioned immediately behind the boat (platform dragging, teak/body surfing). This practice not only poses the risk of extreme physical harm, but also places that person in an area of high engine exhaust concentration.

Good Ventilation

Ventilate the passenger area by opening side curtains or forward hatches.

The following image shows an example of desired air flow through the boat.

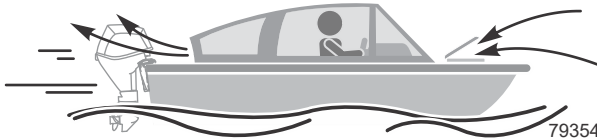

IMPORTANT SAFETY INFORMATION

Poor Ventilation

- **Boat in Motion:** Under certain running or wind conditions, permanently enclosed or canvas enclosed cabins or cockpits with insufficient ventilation may draw in carbon monoxide. The following shows examples of poor ventilation while the boat is moving.

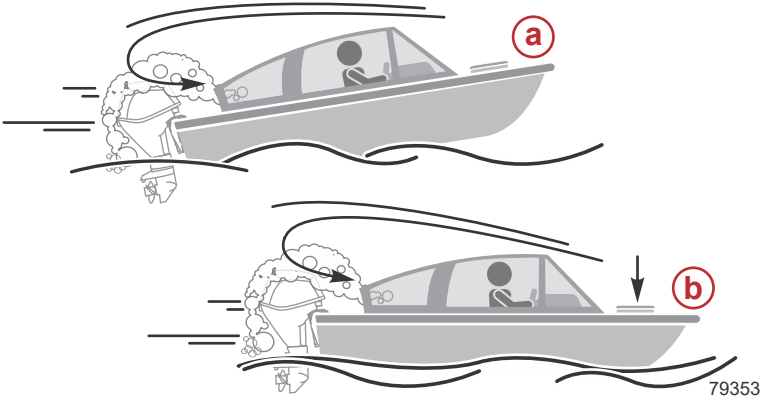

- a -** Operating the boat with the trim angle of the bow too high
 - b -** Operating the boat with no forward hatches open
- **Stationary Boat:** Although the occurrence is rare, on a calm day, persons in an open area of a stationary boat that contains, or is near, a running engine may be exposed to a hazardous level of carbon monoxide. The following shows examples of poor ventilation while the boat is stationary.

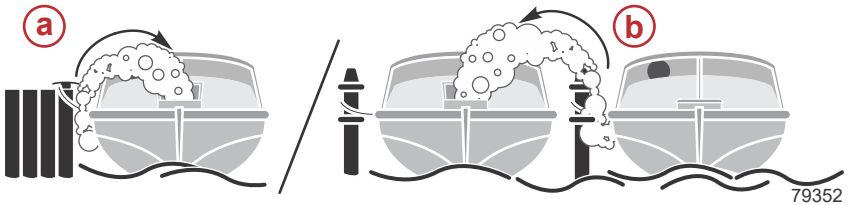

- a -** Operating the engine when the boat is moored in a confined space
 - b -** Mooring close to another boat that has its engine operating

IMPORTANT SAFETY INFORMATION

Outboard Mounting Notice

⚠ WARNING

Failure to correctly fasten the outboard could result in the outboard propelling off the boat transom resulting in property damage, serious injury, or death. Before operation, the outboard must be correctly installed with the required mounting hardware.

IMPORTANT: This outboard must be secured to the transom with the four provided 1/2 in. diameter mounting bolts and locknuts. Two bolts must be installed through the upper set of holes and two bolts through the lower set of holes.

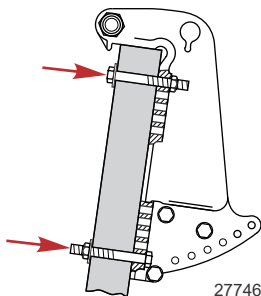

To ensure optimal performance, installation of this outboard and related accessories is best done by trained technicians at a Mercury Marine Authorized Dealer. Owners choosing to install the outboard themselves should refer to the **Outboard Installation** section.

Outboard Remote Control Models

⚠ WARNING

Starting the engine with the drive in gear can cause serious injury or death. Never operate a boat that does not have a neutral-safety-protection device.

IMPORTANT SAFETY INFORMATION

The outboard's remote control must be equipped with a start-in-neutral-only protection device. The device prevents the engine from starting when the shift control is in any position other than neutral.



Lanyard Stop Switch

The purpose of a lanyard stop switch is to turn off the engine when the operator moves far enough away from the operator's position (as in accidental ejection from the operator's position) to activate the switch. Tiller handle outboards and some remote control units are equipped with a lanyard stop switch. A lanyard stop switch can be installed as an accessory - generally on the dashboard or side adjacent to the operator's position.

A decal near the lanyard stop switch provides a visual reminder for the operator to attach the lanyard to their personal flotation device (PFD) or wrist.

The lanyard cord is usually 122–152 cm (4–5 feet) in length when stretched out, with an element on one end that inserts into the switch and a clip on the other end that attaches to the operator's PFD or wrist. The lanyard cord is coiled to prevent entanglement with nearby objects. The cord's extended length minimizes accidental activation should the operator choose to move around in an area close to the normal operator's position. If a shorter lanyard is desired, wrap the lanyard around the operator's wrist or leg, or tie a knot in the lanyard.

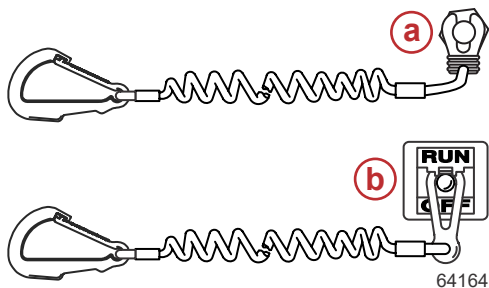

Lanyard stop switch and cord examples

- a - Tiller handle lanyard
- b - Remote control lanyard

IMPORTANT SAFETY INFORMATION

Lanyard Stop Switch and Safe Operation

WARNING

If the operator falls out of the boat, stop the engine immediately to reduce the possibility of serious injury or death from being struck by the boat. Always properly connect the operator to the stop switch using a lanyard.

IMPORTANT: Instruct at least one other boat occupant on proper starting and operating procedures, should they be required to operate the boat in an emergency.

Activation of the lanyard stop switch will stop the engine immediately. However, a boat will continue to coast for some distance depending upon the velocity and degree of any turn at shutdown. While the boat is coasting, it can cause injury to anyone in the boat's path as seriously as it would when under power.

The lanyard stop switch stops the engine whenever the operator moves far enough away from the operator's position to activate the switch. This occurs if:

- The operator accidentally falls overboard, or
- The operator moves within the boat away from the operator's position.

Falling overboard and accidental ejections are more likely to occur in certain types of boats such as:

- Low-sided inflatables
- Bass boats
- High performance boats
- Light, sensitive-handling fishing boats operated by a hand tiller

Falling overboard and accidental ejections are also likely to occur as a result of poor operating practices such as:

- Sitting on the back of the seat or gunwale at planing speeds
- Standing at planing speeds
- Sitting on elevated fishing boat decks
- Riding in forward seating (such as in a bow rider) at planing speeds in rough water
- Operating at planing speeds in shallow or obstacle filled waters
- Releasing a steering wheel or tiller handle that is pulling in one direction
- Drinking alcohol or consuming drugs
- Performing high-speed boat maneuvers

Accidental or unintended activation of the switch during normal operation is also a possibility. This could cause any, or all, of the following potentially hazardous situations:

IMPORTANT SAFETY INFORMATION

- Occupants could be thrown forward due to unexpected loss of forward motion - a particular concern for passengers in the front of the boat who could be ejected over the bow and possibly struck by the boat.
- Loss of power and directional control in heavy seas, strong current, or high winds.
- Loss of control when docking.

To avoid accidental switch activation, the operator should always be aware of their position in relation to the lanyard stop switch and should:

- Never move away from the operating position while the boat is in motion.
- Never move away from the operating position while the boat is stationary without first disconnecting the lanyard from their person.

Keep the Lanyard Stop Switch and Lanyard Cord in Good Operating Condition

Before each use, check to ensure that the lanyard stop switch works properly. Start the engine and stop it by pulling the lanyard cord. If the engine does not stop, have the switch repaired before operating the boat.

Before each use, visually inspect the lanyard cord to ensure it is in good working condition and that there are no breaks, cuts, or wear to the cord. Check that the clips on the ends of the cord are in good condition. Replace any damaged or worn lanyard cords.

Staying Safe Around the Outboard

⚠ CAUTION

Prevent injuries from slips and falls while at or near the back of the boat. Surfaces may be uneven or slippery. Keep clear and avoid using any part of the outboard engine as a stabilizer for balance support or as a handhold, foothold, or ladder.

Even when it is not operating, an outboard engine can present hazards to people in the boat and in the water.

- Always ensure that all passengers stay clear of the engine, whether the boat is in motion or stationary and whether the engine is operating or is shut off.
- Never use the outboard as a seat.
- Never use any portion of the outboard as a step.
- Never climb on any part of the outboard or use any portion of it as a handhold.

IMPORTANT SAFETY INFORMATION

Safe Operating Practices

Passenger Safety - Pontoon Boats and Deck Boats

Whenever the boat is in motion, observe the location of all passengers. Do not allow any passengers to stand or use seats other than those designated for traveling faster than idle speed. A sudden reduction in boat speed, such as plunging into a large wave or wake, a sudden throttle reduction, or a sharp change of boat direction, could throw them over the front of the boat. Falling over the front of the boat between the two pontoons will position them to be run over by the outboard.

Boats with an Open Front Deck

⚠ WARNING

Sitting or standing in an area of the boat not designed for passengers at speeds above idle can cause serious injury or death. Stay back from the front end of deck boats or raised platforms and remain seated while the boat is in motion.

No one should ever be on the deck in front of the fence while the boat is in motion. Keep all passengers behind the front fence or enclosure.

Persons on the front deck could easily be thrown overboard or persons dangling their feet over the front edge could get their legs caught by a wave and pulled into the water.

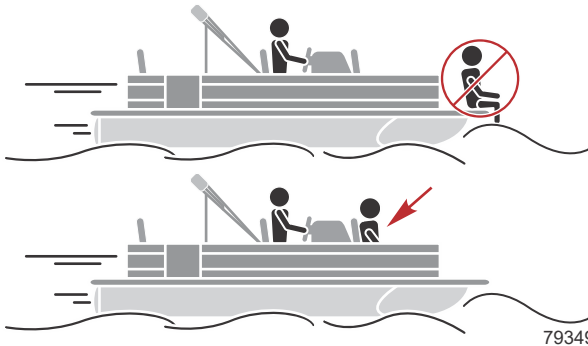

Boats with Front-Mounted, Raised Pedestal Fishing Seats

Elevated fishing seats are not intended for use when the boat is traveling faster than idle or trolling speed. Sit only in seats designated for traveling at faster speeds.

IMPORTANT SAFETY INFORMATION

Any unexpected, sudden reduction in boat speed could result in the elevated passenger falling over the front of the boat.



Protecting People in the Water

While the Boat is in Operation

People in the water cannot take quick action to avoid a boat heading in their direction.



Approach slowly and exercise extreme caution when boating in areas where people may be in the water.

When a boat is moving and the gear shift is in neutral, there is sufficient force by the water on the propeller to cause the propeller to rotate. This neutral propeller rotation can cause serious injury.

While the Boat is Stationary

⚠ WARNING

A spinning propeller, a moving boat, or any solid device attached to the boat can cause serious injury or death to swimmers. Stop the engine immediately whenever anyone in the water is near the boat.

Shift into neutral and shut down the engine before allowing people in the water near the boat.

IMPORTANT SAFETY INFORMATION

Safe Boating Recommendations

To safely enjoy the waterways, boat operators must be familiar with local and all other governmental boating regulations and restrictions. Boaters should also consider the following suggestions.

- **Know and obey all nautical rules and laws of the waterways.**
 - All powerboat operators are advised to complete a boating safety course. In the U.S., the U.S. Coast Guard Auxiliary, the Power Squadron, the Red Cross, and the state or provincial boating law enforcement agency provide courses. For more information, visit the Boat U.S. Foundation website at <https://boatus.org/>.
 - Some locations (states, territories, etc.) *require* a boating license or certificate. Always confirm licensing and certification requirements prior to boating in a new location.
- **Perform safety checks and required maintenance.** Follow a regular schedule and ensure that all repairs are properly made.
- **Check onboard safety equipment.** Regulating bodies in most areas *require* specific safety equipment on every powered boat. Even if not required, consider carrying the following on board, and always check the condition before each outing:
 - Approved fire extinguishers
 - Paddle or oar
 - Two-way radio
 - Weather radio
 - Compass and map or chart of the area
 - Signal devices: flashlight, rockets or flares, flag, and whistle or horn
 - Drinking water
 - First aid kit and instructions
 - Waterproof storage containers
 - Anchor and extra anchor line
 - Spare operating equipment, batteries, bulbs, and fuses
 - Manual bilge pump and extra drain plugs
 - Tools necessary for minor repairs
- **Watch for signs of weather change and avoid foul weather and rough-sea boating.**
- **Tell someone of the boating plans, including the expected route and estimated time of return.**
- **Passenger boarding:** Stop the engine whenever passengers are boarding, unloading, or are near the back (stern) of the boat. Shifting the drive unit into neutral is not sufficient.
- **Use personal flotation devices (PFDs).**

IMPORTANT SAFETY INFORMATION

- U.S. federal law *requires* that there be a U.S. Coast Guard-approved life jacket (personal flotation device), correctly sized and readily accessible for every person onboard, plus a type 4 throwable cushion or ring. It is strongly advised that everyone wear a life jacket at all times while in the boat.
- U.S. federal law *requires* children 13 years of age and younger to wear a U.S. Coast Guard-approved personal flotation device while the boat is underway.
- Use of personal flotation devices may be *mandatory* in areas outside of the U.S. Always check local laws and regulations before embarking.
- Inspect the condition of all PFDs prior to embarking.
- **Prepare other boat operators.** Instruct at least one person onboard on the basics of starting and operating the engine and boat handling in case the driver becomes disabled or falls overboard.
- **Do not overload the boat.** Most boats are rated and certified for maximum load (weight) capacities (refer to the boat's capacity plate). Know the boat's operating and loading limitations. Know if the boat will float if it is full of water. When in doubt, contact a Mercury Marine Authorized Dealer or the boat manufacturer.
- **Ensure that everyone in the boat is properly seated.** Do not allow anyone to sit or ride on any part of the boat that was not intended for such use. This includes:
 - Backs of seats
 - Gunwales
 - Transom
 - Bow
 - Decks
 - Raised fishing seats
 - Any rotating fishing seatPassengers should not sit or ride anywhere that sudden unexpected acceleration, sudden stopping, unexpected loss of boat control, or sudden boat movement could cause them to be thrown overboard or into the boat. Ensure that all passengers have a proper seat and are in it before any boat movement.
- **Never operate a boat while under the influence of alcohol or drugs. It is the law.** Alcohol or drugs can impair human judgment and greatly reduce the ability to react quickly.
- **Know the boating area and avoid hazardous locations.**

IMPORTANT SAFETY INFORMATION

- **Be alert.** The operator of the boat is responsible by law to maintain a proper lookout by sight and hearing. The operator must have an unobstructed view, particularly to the front. No passengers, load, or fishing seats should block the operator's view when the boat is above idle or planing transition speed. Watch out for others, the water, and the wake.
- **Never drive the boat directly behind a water-skier.** A boat traveling at 40 km/h (25 mph) will overtake a fallen skier who is 61 m (200 ft) in front of the boat in five seconds.
- **Observe safe practices for using the boat for skiing, wake-boarding, or similar activity.**
 - A minimum of two persons should be onboard the boat whenever a skier is in the water: one to drive the boat and one to act as a spotter (facing the skier at all times).
 - Always keep a fallen or down skier on the operator's side of the boat while returning to attend to the skier. The operator should always have the down skier in sight and never back up to the skier or anyone in the water.
 - Some U.S. states and Canadian provinces require a "skier down" flag, have restrictions on spotter age, have rearview mirror requirements, and so forth. Know and obey all federal, state (provincial), and local laws and regulations.
- **Report accidents.**
 - In the U.S., boat operators are *required* by law to file a boating accident report with their state boating law enforcement agency when their boat is involved in certain boating accidents. A boating accident must be reported if:
 - i. There is loss of life or probable loss of life.
 - ii. There is personal injury requiring medical treatment beyond first aid.
 - iii. There is damage to boats or other property where the damage value exceeds \$2,000.00 (lower amounts in some states and territories).
 - iv. There is complete loss of the boat.Seek further assistance from local law enforcement.
 - Accident reporting requirements may vary in areas outside the U.S.

Wave and Wake Jumping

WARNING

Wave or wake jumping can cause serious injury or death from occupants being thrown within or out of the boat. Avoid wave or wake jumping whenever possible.

IMPORTANT SAFETY INFORMATION

Operating recreational boats over waves and wake is a natural part of boating. However, when this activity is done with sufficient speed to force the boat hull partially or completely out of the water, certain hazards arise, particularly when the boat re-enters the water.



The primary concern is the boat changing direction while in the midst of the jump. In such case, the landing may cause the boat to spin or veer violently in a new direction. Such a sharp change in direction can cause occupants to be thrown out of their seats, or out of the boat.

There is another less common hazardous result from allowing a boat to launch off a wave or wake. If the bow of the boat pitches down far enough while airborne, upon water contact it may penetrate under the water surface and submarine for an instant. This will bring the boat to a nearly instantaneous stop and can send the occupants flying forward. The boat may also steer sharply to one side.

Impact with Underwater Hazards

⚠ WARNING

Operating a boat or engine with impact damage can result in product damage, serious injury, or death. If the vessel experiences any form of impact, have a Mercury Marine Authorized Dealer inspect and repair the vessel or power package.

This outboard is equipped with a hydraulic trim and tilt system that also contains a shock absorbing feature. This feature helps the outboard withstand damage in the case of impact with an underwater object at low to moderate speeds. At higher speeds, the force of the impact may exceed the system's ability to absorb the energy of the impact and cause serious product damage.

No impact protection exists while in reverse. Use extreme caution when operating in reverse to avoid striking underwater objects.

IMPORTANT SAFETY INFORMATION

Reduce speed and proceed with caution when driving a boat in shallow water areas or in areas where underwater obstacles may exist that could be struck by the outboard or the boat bottom. **The most significant action that can help reduce injury or impact damage from striking a floating or underwater object is to control the boat speed. Under these conditions, boat speed should be kept to the minimum planing speed, typically 24 to 40 km/h (15 to 25 mph).**

⚠ WARNING

Avoid serious injury or death from all or part of an outboard or drive unit coming into the boat after striking a floating or underwater object. When operating in waters where objects may be at the surface or just under the surface of the water, reduce speed and keep a vigilant lookout.

Examples of objects that can cause engine damage are dredging pipes, bridge supports, wing dams, trees, stumps, and rocks.



Striking a floating or underwater object could result in any of a number of situations. Some of these situations could yield the following:

- Part of the outboard or the entire outboard could break loose and fly into the boat.
- The boat could move suddenly in a new direction. A sharp change in direction can cause occupants to be thrown out of their seats or out of the boat.
- The boat's speed could rapidly reduce. This will cause occupants to be thrown forward or even out of the boat.
- The outboard or boat could sustain impact damage.

After striking a submerged object, stop the engine as soon as possible and inspect it for any broken or loose parts. If damage is present or suspected, the outboard should be taken to an authorized dealer for a thorough inspection and necessary repair.

The boat should also be checked for any hull fractures, transom fractures, or water leaks. If water leaks are discovered after an impact, immediately activate the bilge pump.

Operating a damaged outboard could cause additional damage to other parts of the outboard or could affect control of the boat. If continued running is necessary, do so at greatly reduced speeds.

GENERAL INFORMATION

Specifications

Specifications - 150

Parameter		Specification
Rated power		110 kW (150 hp)
Full throttle range		5000–5800 RPM
Idle speed in neutral gear	Cold warm-up	650–800 RPM
	At operating temperature	650 RPM
	Idle charging compensation*	650–800 RPM
Number of cylinders		4
Piston displacement		3.0 L (183 cid)
Spark plug	Recommended model	NGK ZFR5F
	Gap	0.8 mm (0.032 in.)
	Hex size	16 mm (5/8 in.)
	Torque	27 Nm (20 lb-ft)
Gear ratio		1.92:1
Recommended fuel		Refer to Fuel and Oil
Recommended oil		Refer to Fuel and Oil
Engine oil capacity with oil filter replacement		6.0 L (6.3 US qt)
Gearcase lubricant capacity	Right-hand rotation	830 mL (28.1 fl oz)
	Left-hand rotation	
Battery rating	Lead acid	1000 MCA, 800 CCA, or 180 Ah
	Lithium-Ion	Refer to Lithium-Ion Cranking Battery Requirements
Emission control system		Electronic engine control (EC)
Sound at driver's ear (ICOMIA 39-94)		82.9 dBA

*The idle speed may automatically increase up to 800 RPM to compensate for a low battery charge condition. The increased idle speed will charge the battery at a higher rate. Activating the troll control (optional accessory) will override this feature.

GENERAL INFORMATION

Specifications - 150 Pro XS

Parameter		Specification
Power		110 kW (150 hp)
Full throttle range		5200–6000 RPM
Idle speed in neutral gear	Cold warm-up	650–800 RPM
	At operating temperature	650 RPM
	Idle charging compensation*	650–800 RPM
Number of cylinders		4
Piston displacement		3.0 L (183 cid)
Spark plug	Recommended model	NGK ZFR5F
	Gap	0.8 mm (0.032 in.)
	Hex size	16 mm (5/8 in.)
	Torque	27 Nm (20 lb-ft)
Gear ratio		2.08:1
Recommended fuel		Refer to Fuel and Oil
Recommended oil		Refer to Fuel and Oil
Engine oil capacity with oil filter replacement		6.0 L (6.3 US qt)
Gearcase lubricant capacity	Right-hand rotation	970 mL (32.8 fl oz)
Battery rating	Lead acid	1000 MCA, 800 CCA, or 180 Ah
	Lithium-Ion	Refer to Lithium-Ion Cranking Battery Requirements
Emission control system		Electronic engine control (EC)
Sound at driver's ear (ICOMIA 39-94)		82.9 dBA

*The idle speed may automatically increase up to 800 RPM to compensate for a low battery charge condition. The increased idle speed will charge the battery at a higher rate. Activating the troll control (optional accessory) will override this feature.

GENERAL INFORMATION

Specifications - 150 SeaPro

Parameter		Specification
Power		110 kW (150 hp)
Full throttle range		4800–5300 RPM
Idle speed in neutral gear	Cold warm-up	650–800 RPM
	At operating temperature	650 RPM
	Idle charging compensation*	650–800 RPM
Number of cylinders		4
Piston displacement		3.0 L (183 cid)
Spark plug	Recommended model	NGK ZFR5F
	Gap	0.8 mm (0.032 in.)
	Hex size	16 mm (5/8 in.)
	Torque	27 Nm (20 lb-ft)
Gear ratio		1.92:1
Recommended fuel		Refer to Fuel and Oil
Recommended oil		Refer to Fuel and Oil
Engine oil capacity with oil filter replacement		6.0 L (6.3 US qt)
Gearcase lubricant capacity	Right-hand rotation	830 mL (28.1 fl oz)
	Left-hand rotation	
Battery rating	Lead acid	1000 MCA, 800 CCA, or 180 Ah
	Lithium-Ion	Refer to Lithium-Ion Cranking Battery Requirements
Emission control system		Electronic engine control (EC)
Sound at driver's ear (ICOMIA 39-94)		82.9 dBA

*The idle speed may automatically increase up to 800 RPM to compensate for a low battery charge condition. The increased idle speed will charge the battery at a higher rate. Activating the troll control (optional accessory) will override this feature.

GENERAL INFORMATION

Lithium-Ion Cranking Battery Requirements

Description	Specification
Chemistry/format	Lithium iron phosphate designed for marine cranking use
Minimum cranking amps	800 A for 8 second minimum at 20 °F (-7 °C)
Peak charge acceptance	165 A 20-130 °F (-7-55 °C) for one minute
Max charge/alternator size	150 A 20-130 °F (-7-55 °C)
Max charge voltage/alternator output	14.8 V
Reserve Capacity (RC25 at 80 °F)	135 minutes
Ingress Protection (IP) rating	IP67 or greater

GENERAL INFORMATION

Component Identification

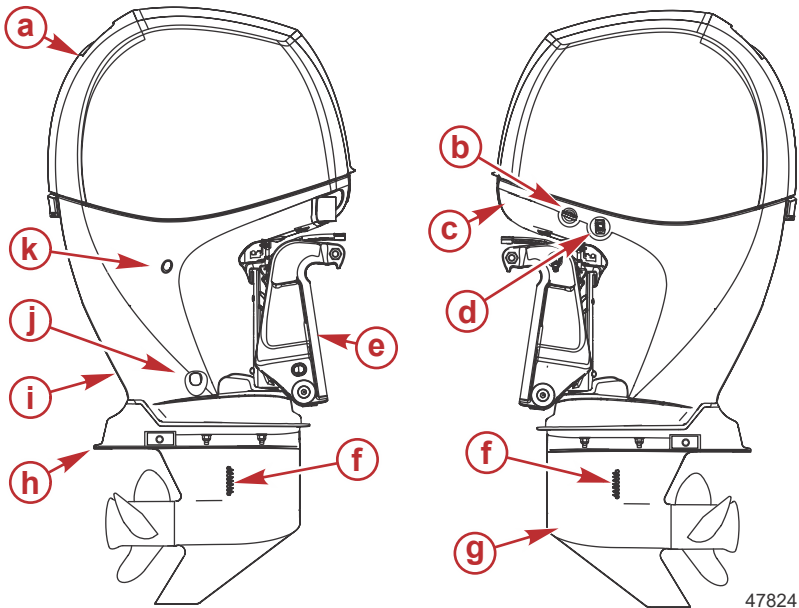

- a** - Top cowl
- b** - Engine flush
- c** - Bottom cowl
- d** - Auxiliary tilt switch
- e** - Transom brackets
- f** - Cooling water intake holes
- g** - Gearcase
- h** - Anti-ventilation plate
- i** - Driveshaft housing
- j** - Engine oil drain
- k** - Water pump indicator hole

Propeller Selection

IMPORTANT: To ensure proper fit and performance, use only Mercury or Quicksilver branded propellers and mounting hardware.

The propeller is one of the most important components in the propulsion system. An improper propeller choice can significantly affect boat performance and could result in damage to the outboard engine. Damage to an engine resulting from the use of an improper propeller is not covered by the Mercury Marine Limited Warranty.

GENERAL INFORMATION

About Propellers

Propellers are designated by the diameter, pitch (the distance the propeller travels through water in a single rotation), number of blades (three and four blade propellers are most common), and material (e.g., aluminum or stainless steel). The diameter and pitch are stamped (cast) into the side or the end of the propeller hub. The first number represents the diameter of the propeller and the second number represents the pitch. For example, 14x19 indicates a propeller with a 14 inch diameter and 19 inches of pitch.

Mercury Marine offers a full selection of aluminum and stainless steel propellers specifically designed for each outboard model. For information about Mercury Marine's line of propellers, visit <https://www.mercurymarine.com/us/en/propellers>.

Original Equipment Propellers

In general, the original equipment propeller will be the best-suited propeller for a given engine.

- Propellers installed by boat builders (OEMs) are selected for each particular boat hull and engine combination. OEMs have the highest level of knowledge of how hull design affects propeller selection.
- Propellers installed at the boat dealer are also selected according to boat hull and engine combination. Dealers will have knowledge of propeller selection criteria not typically held by the consumer.
- A damaged propeller should always be replaced with the same model propeller.

Upgrading a Propeller

Customers considering upgrading their propeller for better performance are advised to contact a Mercury Marine Authorized dealer, who will be familiar with a variety of boat hull and engine applications.

Required Propellers

Some engines require the use of a particular propeller and a particular propeller hub. Such requirements may be listed in **General Information - Specifications**. Be aware that any published propeller requirement is subject to change without notice. It is always best to consult a Mercury Marine Authorized dealer before purchasing a new propeller.

Recording Serial Number

Record the serial number and model designation for future reference. An **Identification Records** table is available for this purpose, at the back of this manual.

GENERAL INFORMATION

A decal containing serial number and model designation is located on the outboard, as shown.

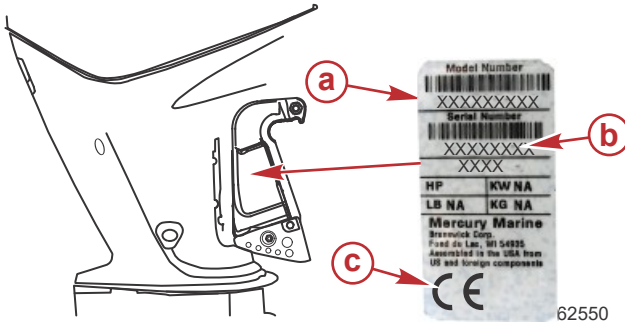

- a** - Model designation
- b** - Serial number
- c** - Certified Europe insignia (as applicable)

Selecting Outboard Accessories

IMPORTANT: Check with an authorized dealer before installing accessories. The misuse of approved accessories or the use of nonapproved accessories can damage the product.

Genuine Mercury Precision or Quicksilver accessories have been specifically designed and tested for each Mercury Marine outboard. These accessories are available from Mercury Marine dealers.

Some accessories not manufactured or sold by Mercury Marine are not designed to be safely used with this outboard or outboard operating system. Read the installation, operation and maintenance manuals for all selected accessories.

Refer to additional information regarding mounting accessories to the transom clamp bracket, in the **Outboard Installation** section.

GENERAL INFORMATION

Notes:

OUTBOARD INSTALLATION

Important Installation Information

The process of rigging boats—including proper engine installation—has become more complex over the years. As a result, Mercury Marine recommends that engines be installed only by Mercury Marine authorized dealers.

Any consumers opting to install an outboard engine on their own are hereby advised to read and comply with the following instructions in their entirety. Failure to comply with these installation instructions could void the product warranty and could lead to serious injury or death.

Mercury Marine Validated Engine Mounting Hardware

IMPORTANT: Do not mount any accessory—such as Tow Sport bars or boarding ladders—onto the boat using the mounting hardware included with the outboard. Installing other products onto the boat by using the outboard mounting hardware will compromise the ability of that hardware to properly and safely secure the outboard to the transom.

Improper installation of the outboard can cause performance and reliability issues that can lead to safety concerns. Follow all instructions relating to outboard installation.

Mercury Marine provides validated fasteners and installation instructions, including torque specifications, with all outboards so they can be properly secured to boat transoms.

Outboards that require validated mounting hardware will have the following decal on the transom clamp.



51965

OUTBOARD INSTALLATION

Transom Fastening Hardware

Outboard Transom Mounting Hardware - Supplied with Outboard

Part Number	Part Name	Description
8M0204730	Outboard mounting bolt	½-20 x 5.00 in. long (3.25 in. thread)
826711-17	Nylon insert locknut	½-20
8M0204648	Flat washer	1.50 in. diameter
8M0204665	Flat washer	0.875 in. diameter

Available Outboard Mounting Bolts

Part Number	Description
67755005	½-20 x 2.50 in. long (1.25 in. thread)
8M0131814	½-20 x 3.50 in. long (1.25 in. thread)
814259	½-20 x 4.00 in. long (2.25 in. thread)
8M0149747	½-20 x 4.50 in. long (2.25 in. thread)
8M0204730	½-20 x 5.00 in. long (3.25 in. thread)
8M0038370	½-20 x 5.50 in. long (3.25 in. thread)
67755-2	½-20 x 6.50 in. long (2.75 in. thread)
8M0028080	½-20 x 7.50 in. long (2.75 in. thread)
8M0032860	½-20 x 8.00 in. long (2.75 in. thread)

Accessories Mounted to the Transom Clamp Bracket

⚠ WARNING
Avoid serious injury or death resulting from a loss of boat control. Loose engine fasteners could cause the transom clamp bracket to fail, resulting in a loss of the driver's ability to control the boat. Always ensure that the engine fasteners are tightened to the specified torque.

Mercury Marine has been made aware that certain aftermarket marine accessories, such as emergency boarding ladders, shallow water anchors, transom wedge kits, and tow sport attaching devices, have been mounted to the boat by use of the same fasteners that secure the outboard to the transom or jack plate. Using the same fastener to secure both an accessory and the engine to the boat compromises the ability of the fasteners to maintain the proper clamp load. A boat with loose engine mounting fasteners creates the possibility of performance, durability, and safety issues.

OUTBOARD INSTALLATION

Acceptable Accessory Mounting

After the engine is mounted to the transom or jack plate in accordance with the engine installation instructions, it is acceptable to attach an accessory to the boat by use of the unused bolt holes in the transom clamp bracket as shown.

The following list provides additional guidelines for mounting accessories to the transom clamp bracket.

- The accessory fasteners must pass through the boat transom or jack plate.
- The installation must not create interference issues, as would an accessory mounting plate resting in the radius of the transom clamp bracket.

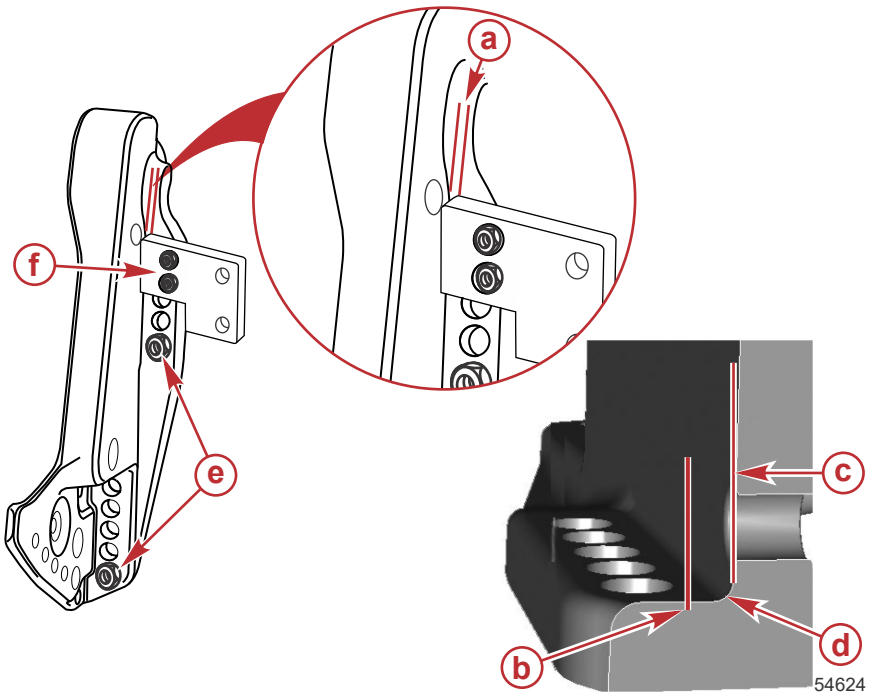

a - Minimum clearance 3.175 mm (0.125 in.)

b - Edge of accessory bracket

c - Transom clamp bracket wall

d - Radius

e - Engine supplied mounting fasteners

f - Fasteners supplied by the accessory manufacturer installed through unused engine mounting bracket holes

OUTBOARD INSTALLATION

Unacceptable Accessory Mounting

IMPORTANT: Do not use the fasteners that secure the engine to the boat (either the transom or the jack plate) for any purpose other than securing the engine to the boat.

- Do not mount an accessory to the transom clamp bracket in an unsupported condition.

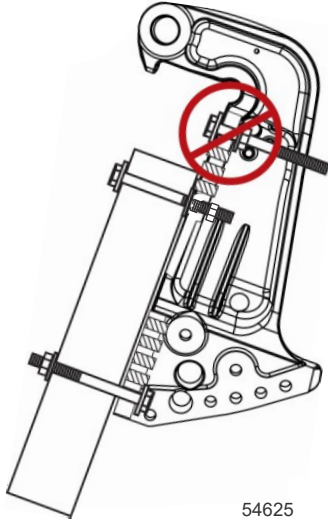

- Do not attach an accessory to the transom clamp bracket by use of the engine mounting hardware.

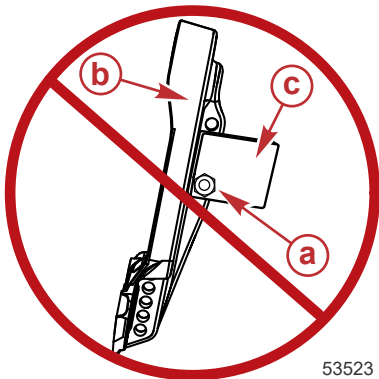

- a** - Supplied engine mounting hardware
- b** - Transom clamp bracket
- c** - Accessory

OUTBOARD INSTALLATION

- Do not install wedges or plates between the transom clamp brackets and the transom (or jack plate).

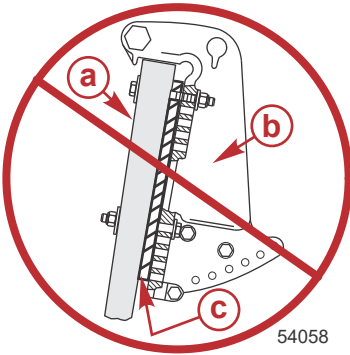

- a** - Boat transom or jack plate
- b** - Transom clamp bracket
- c** - Wedge/plate

Fuel System

Accessory Electric Fuel Pump

IMPORTANT: Do not install an accessory electric fuel pump onto the fuel system for this engine.

Avoiding Fuel Flow Restriction

IMPORTANT: Adding components to the fuel supply system (filters, valves, fittings, etc.) may restrict the fuel flow. This may cause engine stalling at low speed, and/or a lean fuel condition at high RPM that could cause engine damage.

Fuel System Requirements

When installing the boat's fuel system, refer to **Fuel and Oil** for fuel system requirements:

- Low Permeation Fuel Hose Requirement
- Fuel Demand Valve (FDV) Requirement
- EPA Pressurized Portable Fuel Tank Requirements
- Mercury Marine's Pressurized Portable Fuel Tank

Fuel Tanks

Portable Fuel Tank

Select a suitable location in the boat within the engine fuel line length limitations and secure the tank in place.

Permanent Fuel Tank

Permanent fuel tanks should be installed in accordance with industry and federal safety standards, which include recommendations applicable to grounding, anti-siphon protection, ventilation, etc.

OUTBOARD INSTALLATION

Priming the Fuel Supply Module

IMPORTANT: The fuel supply module must be primed before the engine is run. Refer to the Fuel Supply Module Priming Procedure in the Operation section.

Transom Cutout and Mounting Holes

Installation Specifications

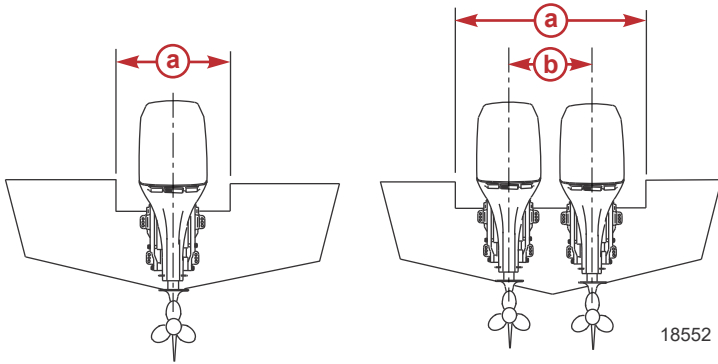

a - Minimum transom opening

b - Engine centerline for dual engines - 66.0 cm (26 in.) minimum

Minimum Transom Opening	
Single engine	84.2 cm (33 in.)
Dual engines	149.9 cm (59 in.)

OUTBOARD INSTALLATION

Determining Recommended Outboard Mounting Height

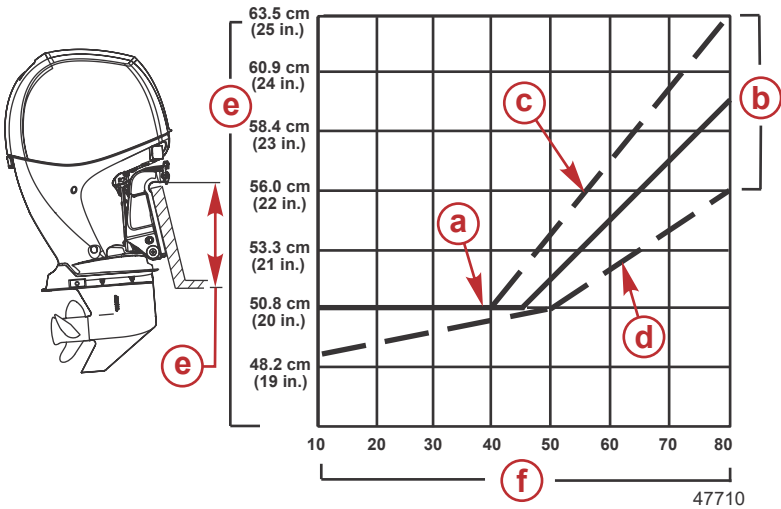

- a** - The solid line is recommended to determine the outboard mounting height
- b** - The broken lines represent the extremes of known successful outboard mounting height dimensions
- c** - This line may be preferred to determine outboard mounting height dimension, if maximum speed is the only objective
- d** - This line may be preferred to determine outboard mounting height dimension for dual outboard installation
- e** - Outboard mounting height (height of outboard mounting brackets from bottom of boat transom). For heights over 56.0 cm (22 in.), a propeller that is designed for surfacing operation is usually preferred.
- f** - Maximum boat speed (MPH) anticipated

NOTICE

1. The outboard should be mounted high enough on the transom so the exhaust relief hole will stay at least 25.4 mm (1 in.) above the waterline when the engine is running at idle speed. Having the exhaust relief hole above the waterline will prevent exhaust restrictions. Exhaust restrictions will result in poor performance at idle.
2. Add 12.7 cm (5 in.) for XL models to the listed outboard mounting heights.
3. The mounting height of the outboard must not exceed 63.5 cm (25 in.) for L models, 76 cm (30 in.) for XL models. Mounting the outboard higher may cause damage to the gearcase components.

OUTBOARD INSTALLATION

Increasing the mounting height will usually:

- Reduce steering torque
- Increase top speed
- Increase boat stability
- Cause propeller to break loose during planing

Transom Bracket Clearance

IMPORTANT: Failure to maintain clearance may damage the transom bracket and cause the transom bracket to fail.

Clearance must be maintained between the boat transom and the outboard transom bracket relief radius area. Adjustments to the position of the Mercury Marine transom drilling fixture may be required to ensure proper clearance of the transom bracket relief radius area.

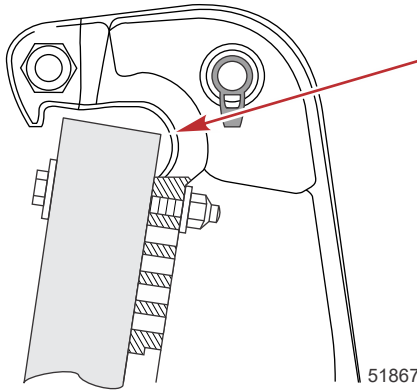

Drilling Outboard Mounting Holes

IMPORTANT: Before drilling any mounting holes, carefully read Determining Recommended Outboard Mounting Height.

1. Place the transom drilling fixture on the boat transom centerline.
 - Features on the fixture help align the center of the fixture with the transom centerline.

OUTBOARD INSTALLATION

- The fixture's drill guide holes mark the proper drilling locations.

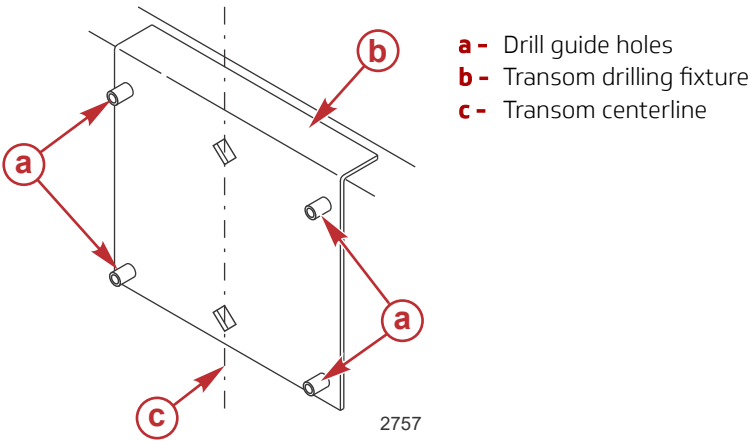

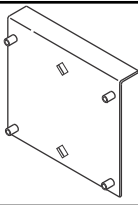
Transom Drilling Fixture	91-98234A2
 <p>5489</p>	Aids in engine installation by acting as a template for engine mounting holes.

2. Drill four 13.5 mm (17/32 in.) mounting holes in the transom, through the drill guide holes.

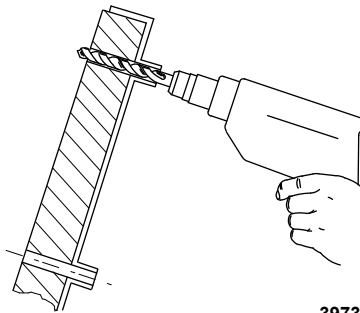

OUTBOARD INSTALLATION

Checking Boat Transom Construction

IMPORTANT: The outboard mounting locknuts and bolts should be able to hold 75 Nm (55 lb-ft) of torque without the boat transom yielding or cracking. If the boat transom yields or cracks under this torque, the construction of the transom may not be adequate. The boat transom must be strengthened or the load carrying area increased.

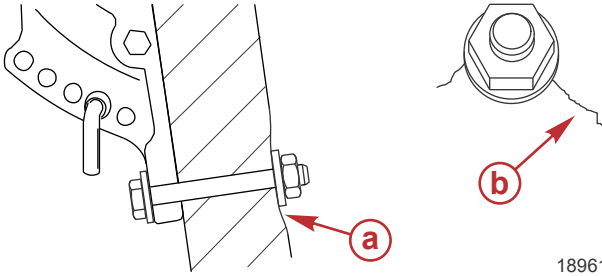

- a** - Transom yielding under bolt torque
- b** - Transom cracking under bolt torque

Use a dial torque wrench to determine transom strength. If the bolt or nut continues to turn without the torque reading on the dial increasing, it is an indication that the transom is yielding. The load area can be increased by using a larger washer or a transom reinforcement plate.

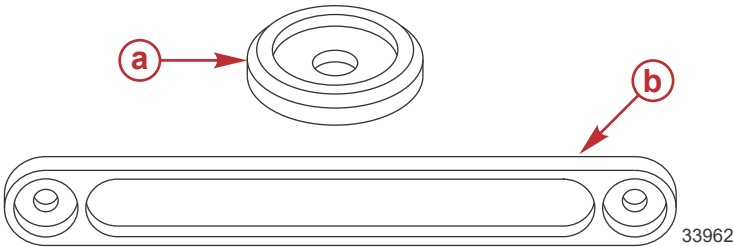

- a** - Large transom washer
- b** - Transom reinforcement plate

Installing the Outboard

Lifting the Outboard

1. Remove the top cowl.
2. Install the lifting base to the flywheel using three bolts. Tighten the bolts securely.
3. Thread the lifting eye into the lifting base.

OUTBOARD INSTALLATION

4. Connect a hoist that has a minimum lift capacity of 450 kg (1000 lb) to the lifting eye.
5. Lift the outboard and place it on the transom.

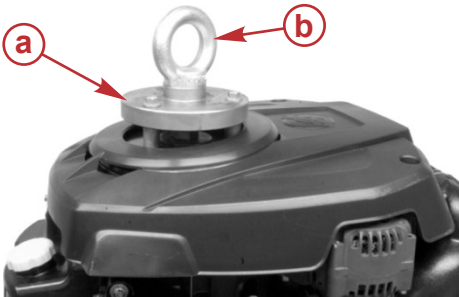

47706

- a** - Lifting base
- b** - Lifting eye

Flywheel Puller/Lifting Ring	91-895343T02
 <p>14869</p>	Removes flywheel from engine. Used for lifting powerhead/engine.

Shipping Bracket Removal

1. Remove the two top screws and loosen the two bottom screws.
2. Slide the shipping bracket off the bottom screws.
3. Tighten the bottom screws to the specified torque.

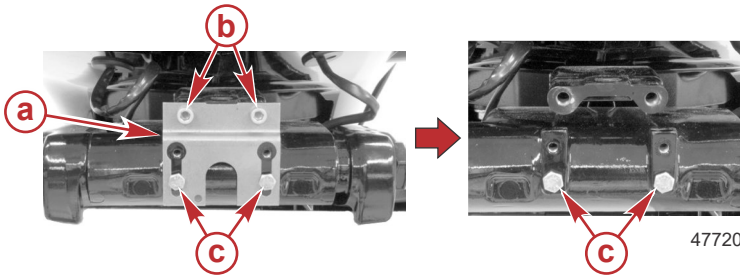

47720

- a** - Shipping bracket
- b** - Top screws
- c** - Bottom screws

Description	Nm	lb-in.	lb-ft
Bottom screws	7.9	70	-

OUTBOARD INSTALLATION

Steering Cable - Starboard Side Routed Cable

1. Lubricate the O-ring seal and entire cable end.

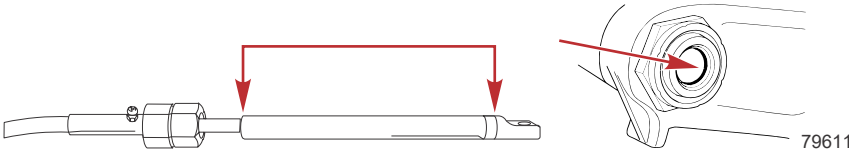

Description	Where Used	Part No.
Extreme Grease	O-ring seal and entire cable end	8M0190472

2. Insert the steering cable into the tilt tube.
3. Tighten the nut to the specified torque.

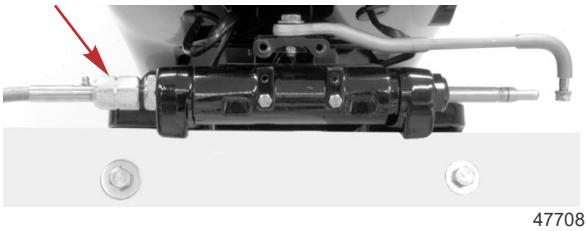

Description	Nm	lb-in.	lb-ft
Nut	47.5	-	35

Fastening the Outboard to the Transom

Transom Surface Flatness

IMPORTANT: No step in the transom mounting surface is allowed. No gap is allowed between the transom and the transom clamp.

- The transom mounting surface must be flat within 3.17 mm (0.125 in.).

OUTBOARD INSTALLATION

- The inside transom mounting bolt washer surface must be flat within 3.17 mm (0.125 in.).

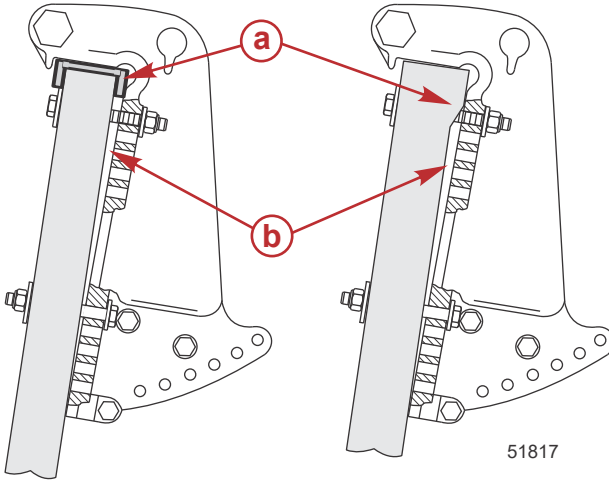

a - Step (not allowed)

b - Gap between transom clamp and boat transom (not allowed)

Outboard Installation

1. Apply marine sealer to the shanks of the bolts, not to the threads.
2. Fasten the outboard with the correct mounting hardware. Tighten the locknuts to the specified torque.

IMPORTANT: Ensure that a minimum of two full threads of the mounting bolts extend beyond the locknut after tightening. The locknut must be drawn tight while still engaging the bolt threads and not contacting the shank of the bolt.

OUTBOARD INSTALLATION

NOTE: For a more accurate torque reading, tighten the mounting locknuts rather than the outboard mounting bolts.

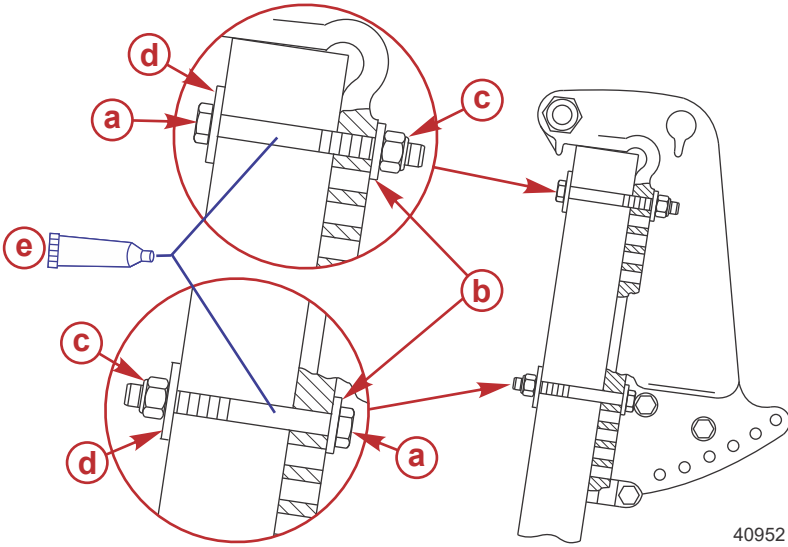

- a** - 0.500 in. diameter outboard mounting bolt (4)
- b** - 0.875 in. flat washer (4)
- c** - Nylon insert locknut (4)
- d** - 1.500 in. flat washer (4)
- e** - Marine sealer – apply to the shank of the bolts, not the threads

Description	Nm	lb-in.	lb-ft
Outboard mounting locknuts and bolts – standard boat transom	75	–	55
Outboard mounting locknuts and bolts – metal lift plates and setback brackets	122	–	90

OUTBOARD INSTALLATION

A decal on the transom bracket reminds the operator to check the fasteners securing the outboard to the transom before each use.

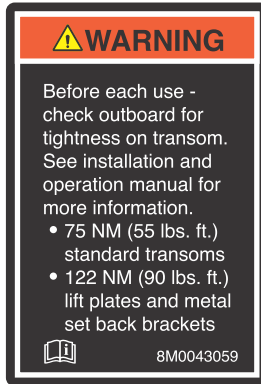

51985

Decal on the transom bracket

Steering Link Rod Installation

⚠ WARNING
Improper fasteners or improper installation procedures can result in loosening or disengagement of the steering link rod. This can cause a sudden, unexpected loss of boat control, resulting in serious injury or death due to occupants being thrown within or out of the boat. Always use required components and follow instructions and torque procedures.

IMPORTANT: Never replace the provided self-locking nylon insert locknuts with common nuts (nonlocking), as they will work loose and vibrate off, freeing the link rod to disengage.

1. Attach the steering link rod to the steering cable with two flat washers and a nylon insert locknut. Tighten the locknut until it seats, then back the nut off 1/4 turn.

Description	Nm	lb-in.	lb-ft
Nylon insert locknut at the steering cable	Tighten until it seats, then back off 1/4 turn		

2. Attach the steering link rod to the steering arm with the special washer head screw and a locknut.
3. Tighten the special washer head screw to the specified torque.

Description	Nm	lb-in.	lb-ft
Special washer head screw	27	–	20

4. Tighten the locknut at the steering arm to the specified torque.

OUTBOARD INSTALLATION

Description	Nm	lb-in.	lb-ft
Nylon insert locknut at the steering arm	27	-	20

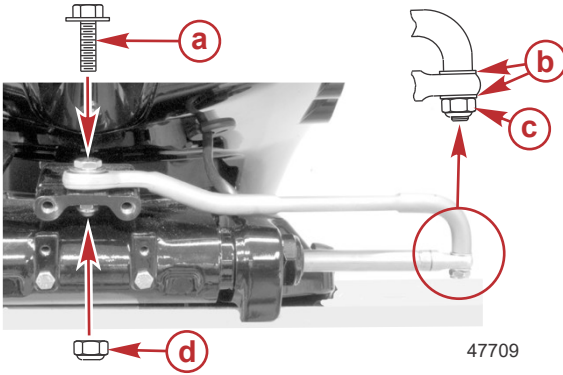

- a** - Special washer head screw (856680)
- b** - Flat washers
- c** - Nylon insert locknut (8M0204726)
- d** - Nylon insert locknut (8M0204726)

Rigging the Engine

Routing Items Through the Rigging Ingress

IMPORTANT: Route all items through the rigging adapter prior to completing the connections at the engine.

A rigging grommet and a rigging adapter are used to secure engine rigging components that pass through the rigging ingress. All items (harnesses, cables, hoses, and tubes) that pass through the rigging ingress must also pass through the rigging adapter and rigging grommet.

OUTBOARD INSTALLATION

The following image shows the rigging ingress, grommet, and adapter, as well as indicating which grommet openings should be used for which rigging items. Keep this arrangement in mind, when routing items through the rigging ingress.

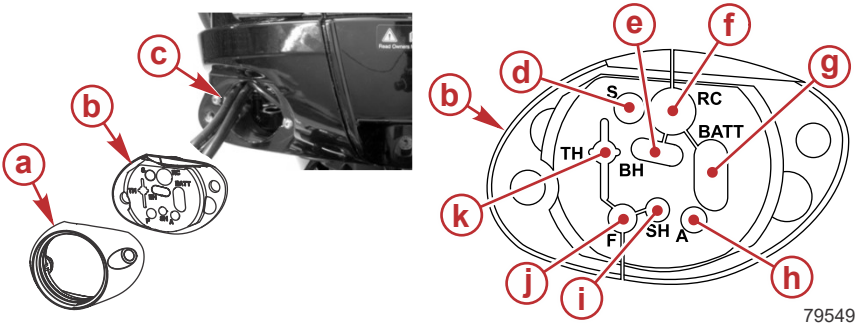

79549

- a** - Rigging adapter
- b** - Rigging grommet
- c** - Rigging ingress
- d** - Speedometer tube opening
- e** - SmartCraft harness or additional harness opening
- f** - Remote 14-pin boat harness opening
- g** - Battery cable opening
- h** - Accessory harness opening
- i** - Shift cable opening
- j** - Fuel hose opening
- k** - Throttle cable opening

Remote Wiring Harness

1. Route the remote 14-pin boat harness through the rigging grommet.
2. Connect the remote harness to the 14-pin connector on the engine harness.

OUTBOARD INSTALLATION

3. Fasten the harness with the retainer.

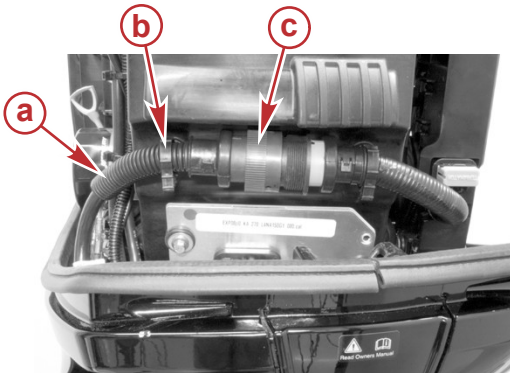

- a** - Remote 14-pin boat harness
- b** - Retainer
- c** - 14-pin connector

47717

SmartCraft Harness and Accessory Harness Connection

If the boat is equipped with a SmartCraft or other accessory harness, route the harness through the rigging adapter, and connect it to the appropriate connector on the engine.

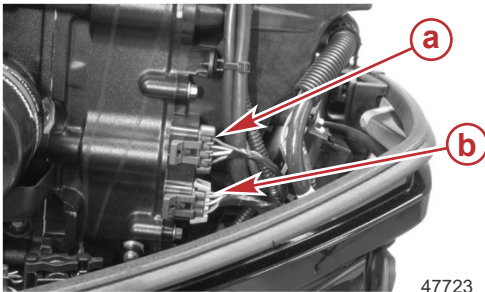

- a** - Accessory harness connector
- b** - SmartCraft harness connector

47723

Shift Cable Installation

Install the throttle and shift control cables into the remote control following the instructions provided with the remote control.

NOTE: Install the shift cable onto the engine before installing the throttle cable. The shift cable is the first cable to move when the remote control handle is moved out of neutral.

1. Position the remote control and the outboard into their neutral positions.

OUTBOARD INSTALLATION

- Center the shift cable anchor pin with the neutral detent alignment mark.

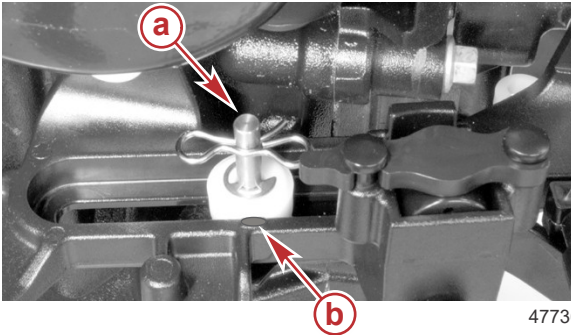

- a** - Shift cable anchor pin
- b** - Neutral detent alignment mark

- Locate the center point of the slack or lost motion that exists in the shift cable as follows:
 - Move the remote control handle from neutral into forward and advance the handle to full speed position. Slowly return the handle back to the neutral position. Place a mark "a" on the cable against the cable end guide.
 - Move the remote control handle from neutral into reverse and advance the handle to full speed position. Slowly return the handle back to the neutral position. Place a mark "b" on the cable against the cable end guide.
 - Make a center mark "c," midway between marks "a" and "b." Align the cable end guide against this center mark when installing the cable to the engine.

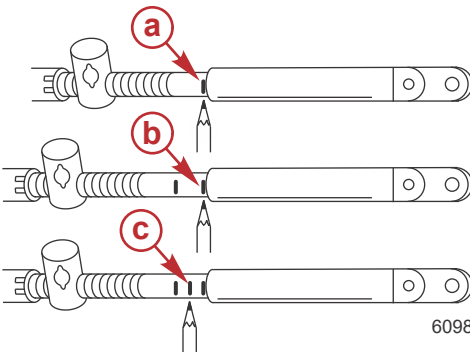

- a** - First mark
- b** - Second mark
- c** - Third mark (center mark)

- Pass the shift cable through the rigging adapter.

OUTBOARD INSTALLATION

- Fit the shift cable through the appropriate hole in the rigging grommet.

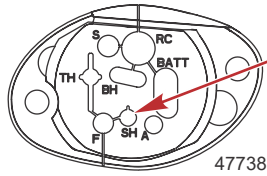

- Position the remote control into neutral.
- Place the barrel cup into the barrel pocket.
- Align the shift cable end guide with the center mark made in step 3.
- Place the shift cable on the anchor pin, and adjust the cable barrel so it slips freely into the barrel cup.
- Secure the shift cable to the anchor pin with the bow tie clip retainer.

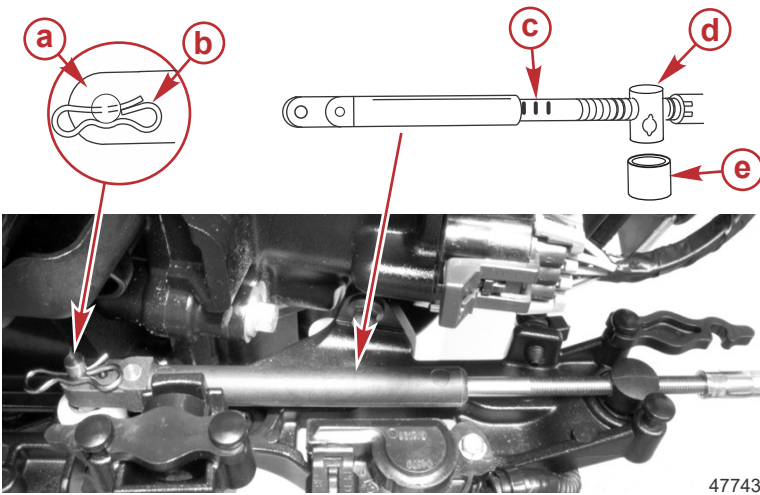

- a** - Shift cable end guide
- b** - Bow tie clip retainer
- c** - Center mark
- d** - Cable barrel
- e** - Barrel cup

OUTBOARD INSTALLATION

11. Lock the barrel in place with the cable latch.

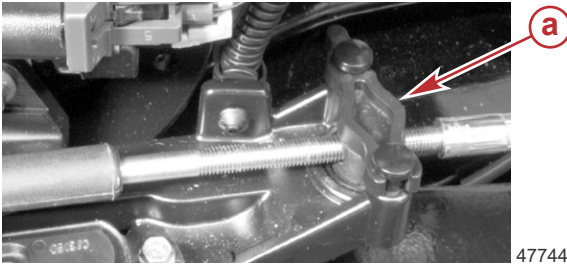

a - Cable latch

12. Check shift cable adjustments as follows:
 - a. Shift remote control into forward. The propeller shaft should be locked in gear. If not, adjust the barrel closer to the cable end.
 - b. Shift remote control into neutral. The propeller shaft should turn freely without drag. If not, adjust the barrel away from the cable end. Repeat steps a and b.
 - c. Shift remote control into reverse while turning propeller. The propeller shaft should be locked in gear. If not, adjust the barrel away from the cable end. Repeat steps a through c.
 - d. Shift remote control back to neutral. The propeller shaft should turn freely without drag. If not, adjust the barrel closer to the cable end. Repeat steps a through d.

Throttle Cable Installation

Install cables into the remote control following the instructions provided with the remote control.

1. Shift remote control into the neutral (N) position.



OUTBOARD INSTALLATION

2. Fit the throttle cable through the rigging grommet.

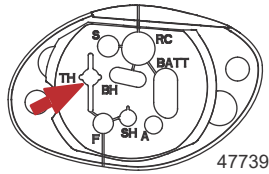

3. Install the throttle cable to the throttle arm with the bow tie clip retainer.
4. Adjust the cable barrel so that the installed throttle cable will hold the throttle arm against the idle stop.
5. Place the barrel cup onto the barrel. Place the cable barrel and barrel cup into the barrel retainer.

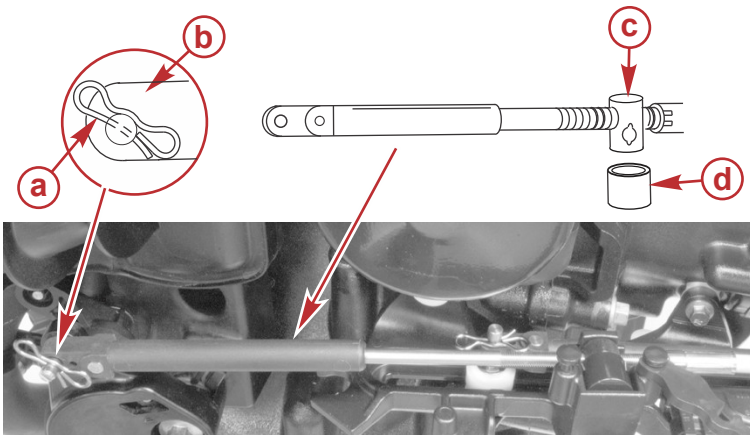

47747

- a** - Bow tie retainer
- b** - Throttle cable end guide
- c** - Cable barrel
- d** - Barrel cup

OUTBOARD INSTALLATION

6. Lock the cable in place with the cable latch.

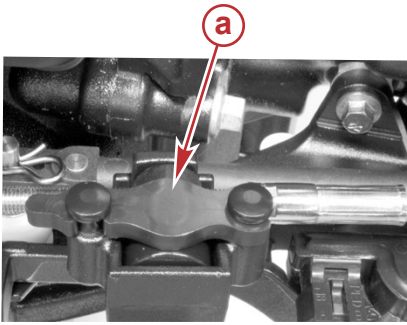

a - Cable latch

47748

Fuel Hose

Fuel Hose Size

The minimum fuel hose inside diameter (ID) is 9.5 mm (3/8 in.). There must be a separate fuel hose/fuel tank pickup for each engine.

Fuel Hose Connection

NOTICE

Inspect the position of the hose clamp to ensure that it will not chafe or cut into the adjacent wiring harnesses.

IMPORTANT: The fuel hose connection (fitting and clamp) must be positioned outside of the rigging grommet, as shown.

Fasten the remote fuel hose to the fitting with a hose clamp. Position the hose clamp so that it will not chafe or cut into an adjacent wiring harness.

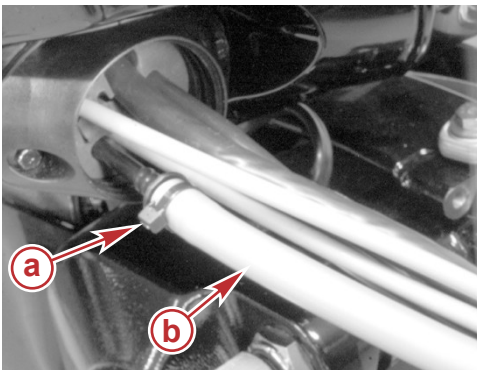

a - Hose clamp on fitting
b - Remote fuel hose

47751

OUTBOARD INSTALLATION

Rigging Grommet and Adapter Installation

IMPORTANT: Leave sufficient slack in wiring harnesses, battery cables, and hoses that are routed through the rigging ingress, to relieve stress and prevent hoses from being kinked or pinched.

1. Ensure that all hoses, wiring, and cables are routed through the rigging adapter.
2. Position all hoses, wiring, and cables in the correct rigging grommet openings, as shown.

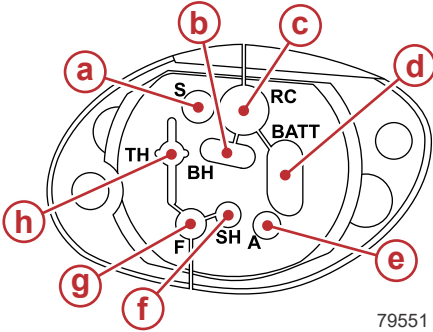

Rigging grommet

- a** - Speedometer tube opening
- b** - SmartCraft harness or additional harness opening
- c** - Remote 14-pin boat harness opening
- d** - Battery cable opening
- e** - Accessory harness opening
- f** - Shift cable opening
- g** - Fuel hose opening
- h** - Throttle cable opening

3. Press the rigging grommet firmly into position over the rigging ingress.
4. Press the adapter into position over the rigging grommet.
5. Fasten the rigging adapter through the grommet and to the engine with two screws. Tighten the screws to the specified torque.

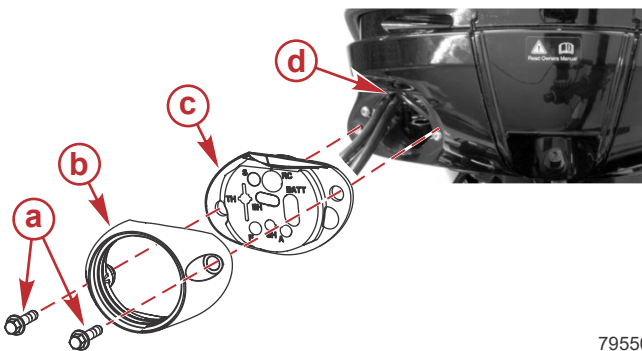

- a** - Screw (2)
- b** - Rigging adapter
- c** - Rigging grommet
- d** - Rigging ingress

OUTBOARD INSTALLATION

Description	Nm	lb-in.	lb-ft
Screws	6	53.1	-

NOTICE

Inspect the position of the hose clamp located on the fuel hose to ensure that it will not chafe or cut into the adjacent wiring harnesses.

- Use a cable tie to hold the wiring, hoses, and cables together.

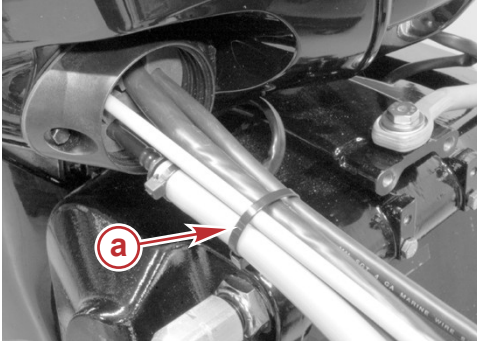

a - Cable tie

47753

Battery Cable Connections

This outboard is factory equipped with 3.6 m (12 ft) #4 gauge battery cables. If battery cables longer than the factory supplied cables are required, the wire gauge size must increase. Refer to the following chart for the correct gauge according to the length.

IMPORTANT: Only copper battery cables should be used. Do not use aluminum power cables in any marine installation.

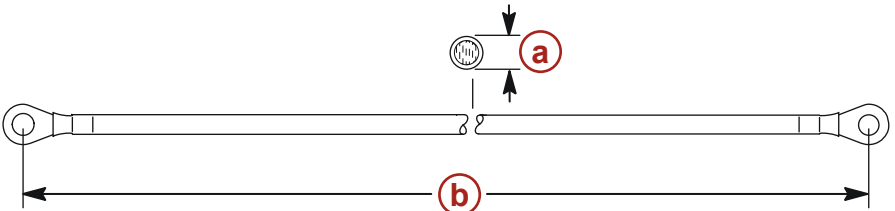

2758

- a** - Wire gauge size
- b** - Cable length

IMPORTANT: The battery cable length specified in the following chart is the sum of both positive and negative cables.

OUTBOARD INSTALLATION

American Wire Gauge (AWG)	Maximum Length
2	12.2 m (40 ft)
1	15.2 m (50 ft)
1/0	19.6 m (64 ft)
2/0	24.4 m (80 ft)

Single Outboard

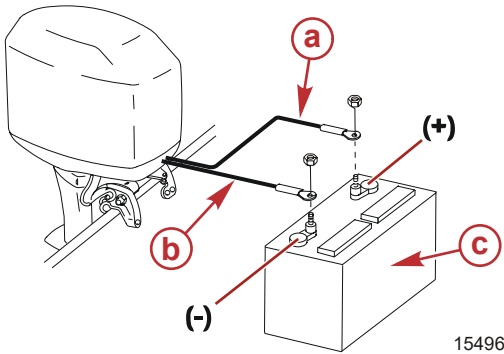

- a** - Red sleeve - positive (+)
- b** - Black sleeve - negative (-)
- c** - Cranking battery

OUTBOARD INSTALLATION

Dual Outboards

Connect a common ground cable (wire size same as engine battery cables) between negative (-) terminals on starting batteries.

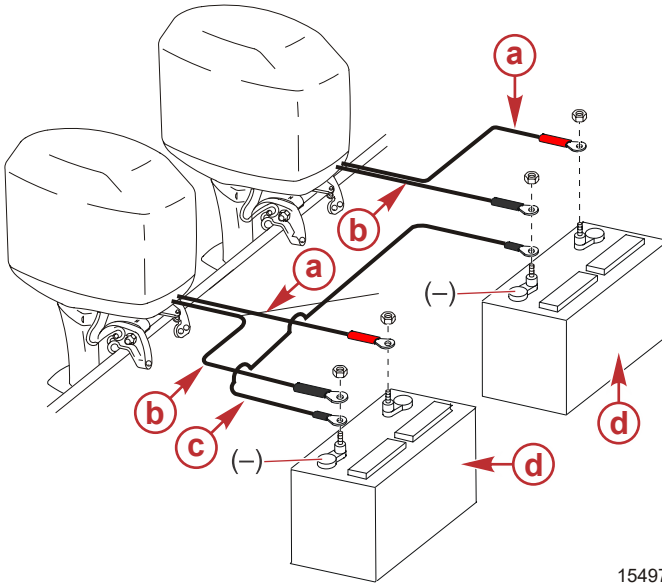

15497

- a** - Red sleeve - positive (+)
- b** - Black sleeve - negative (-)
- c** - Ground cable
- d** - Cranking battery

OUTBOARD INSTALLATION

Notes:

TRANSPORTING

Aquatic Invasive Species (AIS)



STOP AQUATIC HITCHHIKERS!™
Be A Good Steward. Clean. Drain. Dry.

For additional information, visit StopAquaticHitchhikers.org.

About AIS

AIS and their spread can detrimentally impact the boating experience and the future of the boating lifestyle. Reducing the spread of AIS has led to significant national efforts to inspect boats moving between water bodies or across state and federal boundaries and could lead to delayed or denied access if AIS are suspected or found on board.

AIS include plant life such as Eurasian watermilfoil and water hyacinth, and animals such as spiny water flea, quagga, and zebra mussels. AIS may vary in size from microscopic, to easily visible to the naked eye, and can live in residual water or mud. These species damage ecosystems and negatively impact fishing by depleting natural food resources, altering the water environment, and changing the structure of the ecosystem.

The impact of AIS has already resulted in the limiting of boating access to many waterways throughout North America, the closure of public boat ramps, and the reduction of availability for fishing and boating across the United States. Many federal, state, and local agencies have enacted laws and regulations for inspections, permits, launch availability, and water access for vessels entering public waterways.

Boats and associated equipment are major contributors to the spread of AIS. Boats that have come into contact with AIS can become a means of transportation through attachment and entrapment.

Boat Cleaning and AIS

Water passes in and out of the space under the engine's lower cowls during normal operation of the boat. When flushing and cleaning the boat to control the spread of AIS, pay attention to this space by directing flushing water into the spaces under the lower cowl.

The engine cooling system can be flushed by operating the engine with the appropriate flushing attachment and introducing heated water to the engine.

Region-Specific Information

For more information about the control of AIS in a specific region, please contact the local area wildlife conservation office or local governmental natural resources office.

Trailing the Boat and Outboard

Trailer the boat with the outboard tilted down, so it is in a vertical operating position.

TRANSPORTING

Additional clearance may be required for railroad crossings, driveways, and trailer bouncing. If additional clearance is required, tilt the outboard up by using an accessory outboard support device. Refer to a Mercury Marine authorized dealer for recommendations.

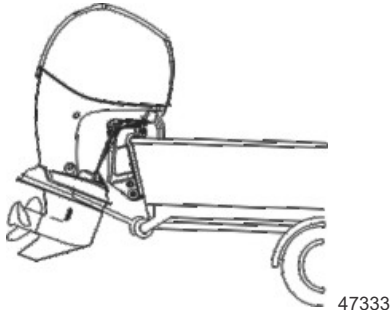

IMPORTANT: Do not rely on the power trim/tilt system or tilt support lever to maintain proper ground clearance for trailering. The outboard tilt support lever is not intended to support the outboard for trailering.

Shift the outboard to forward gear. This prevents the propeller from spinning freely.

FUEL AND OIL

Fuel Requirements

IMPORTANT: Use of improper gasoline can damage an engine. Engine damage resulting from the use of improper gasoline is considered misuse of the engine and will not be covered under the Limited Warranty or legal guarantee (if applicable).

Fuel Ratings

Mercury outboard engines will operate satisfactorily with any major brand of unleaded gasoline that meets the following specifications:

- **USA and Canada** - A posted pump octane rating of 87 (R+M)/2, minimum, for most models. Premium gasoline 91 (R+M)/2 octane is also acceptable for most models. **Do not** use leaded gasoline.
- **Outside USA and Canada** - A posted pump octane rating of 91 RON, minimum, for most models. Premium gasoline (95 RON) is also acceptable for all models. **Do not** use leaded gasoline.

Using Reformulated (Oxygenated) Gasoline (USA Only)

Reformulated gasoline is required in certain areas of the USA and is acceptable for use in Mercury Marine engines. The only oxygenate currently in use in the USA is alcohol (ethanol, methanol, or butanol).

Gasoline Containing Alcohol

Bu16 Butanol Fuel Blends

Fuel blends of up to 16.1% butanol (Bu16) that meet the published Mercury Marine fuel rating requirements are an acceptable substitute for unleaded gasoline. Contact the boat manufacturer for specific recommendations on the boat's fuel system components (fuel tanks, fuel lines, and fittings).

Methanol and Ethanol Fuel Blends

IMPORTANT: The fuel system components on Mercury Marine engines will withstand up to 10% alcohol (methanol or ethanol) content in the gasoline. Some boat fuel systems may not be capable of withstanding the same percentage of alcohol. Contact the boat manufacturer for specific recommendations for boat-specific fuel system components (fuel tanks, fuel lines, and fittings).

Be aware that gasoline containing methanol or ethanol may cause increased:

- Corrosion of metal parts
- Deterioration of rubber or plastic parts
- Fuel permeation through the rubber fuel lines
- Likelihood of phase separation (water and alcohol separating from the gasoline in the fuel tank)

FUEL AND OIL

⚠ WARNING

Fuel leakage is a fire or explosion hazard, which can cause serious injury or death. Periodically inspect all fuel system components for leaks, softening, hardening, swelling, or corrosion, particularly after storage. Any sign of leakage or deterioration requires replacement before further engine operation.

IMPORTANT: When using gasoline that contains or might contain methanol or ethanol, increase the frequency of inspection for leaks and abnormalities.

IMPORTANT: When operating a Mercury Marine engine on gasoline containing methanol or ethanol, do not store the gasoline in the fuel tank for long periods. Cars normally consume these blended fuels before they can absorb enough moisture to cause trouble; boats often sit idle long enough for phase separation to take place. Internal corrosion may occur during storage if alcohol has washed protective oil films from internal components.

Fuel Additives

To minimize carbon deposit buildup in the engine, add Mercury or Quicksilver Quickleen Engine and Fuel System Cleaner to the engine's fuel tank periodically throughout the boating season. Use the additive as directed on the container.

Description	Where Used	Part No.
Quickleen Engine & Fuel System Cleaner	Fuel tank	8M0047931

Fuel Demand Valve (FDV) Requirement

Whenever a pressurized fuel tank is used, a fuel demand valve is required to be installed in the fuel hose between the fuel tank and the engine. The fuel demand valve prevents pressurized fuel from entering the engine and causing a fuel system overflow or possible fuel spillage.

The fuel demand valve has a manual release. The manual release can be used (pushed in) to open (bypass) the valve in case of a fuel blockage in the valve.

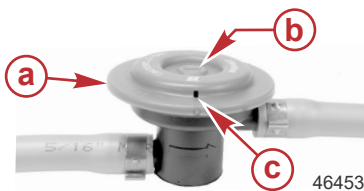

- a -** Fuel demand valve - installed in the fuel hose between the fuel tank and the engine
- b -** Manual release
- c -** Vent/water drain holes

FUEL AND OIL

Fuel Tank

EPA Pressurized Portable Fuel Tank Requirements

The Environmental Protection Agency (EPA) requires portable fuel systems that are produced after January 1, 2011, for use with outboard engines to remain fully sealed (pressurized) up to 34.4 kPa (5.0 psi). These tanks may contain the following:

- An air inlet that opens to allow air to enter as the fuel is drawn out of the tank.
- An air outlet that opens (vents) to the atmosphere if pressure exceeds 34.4 kPa (5.0 psi).

Mercury Marine's Pressurized Portable Fuel Tank

Mercury Marine has created a portable pressurized fuel tank that meets the preceding EPA requirements. This fuel tank is available as an accessory and is provided with certain portable outboard models.

Special Features of the Portable Fuel Tank

- The fuel tank has a two-way valve that allows air to enter the tank as the fuel is drawn to the engine, and also opens to vent to the atmosphere if internal pressure in the tank exceeds 34.4 kPa (5.0 psi). A hissing noise may be heard as the tank vents to the atmosphere. This is normal.
- The fuel tank includes a fuel demand valve that prevents pressurized fuel from entering the engine and causing a fuel system overflow or possible fuel spillage.
- The fuel cap has a built-in device that prevents overtightening. An audible click signifies that the cap is fully seated.
- The fuel tank has a manual vent screw that should be closed for transportation and open for operation and cap removal.

Since sealed fuel tanks are not vented, they will expand and contract as the fuel expands and contracts during heating and cooling cycles of the outside air. This is normal.

Removing the Fuel Cap

IMPORTANT: Contents may be under pressure. Rotate the fuel cap 1/4 turn to relieve pressure before opening.

1. Open the manual vent screw on top of the fuel cap.
2. Turn the fuel cap until it contacts the tab lock.
3. Press down on the tab lock. Rotate the fuel cap 1/4 turn to relieve the pressure.

FUEL AND OIL

- Press down on the tab lock again and remove the cap.

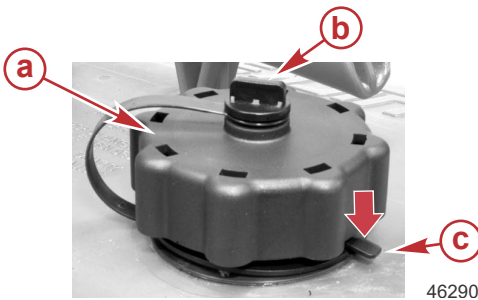

- a** - Fuel cap
- b** - Manual vent screw
- c** - Tab lock

Using the Pressurized Portable Fuel Tank

- When installing the fuel tank cap, turn the cap to the right until there is an audible click. The click signals that the fuel cap is fully seated. A built-in device prevents overtightening.
- Open the manual vent screw on top of the cap for operation and cap removal. Close the manual vent screw for transportation.
- For fuel hoses that have quick disconnects, disconnect the fuel line from the engine or fuel tank when not in use.
- For fueling instructions, refer to **Filling Fuel Tank**.

Filling Fuel Tank

⚠ WARNING

Avoid serious injury or death from a gasoline fire or explosion. Use caution when filling fuel tanks. Always stop the engine and do not smoke or allow open flames or sparks in the area while filling fuel tanks.

Fill the fuel tanks outdoors away from heat, sparks, and open flames.

Remove the portable fuel tanks from the boat to fill them.

Always stop the engine before filling the tanks.

Do not completely fill the fuel tanks. Leave approximately 10% of the tank volume unfilled. Fuel will expand in volume as its temperature rises and can leak under pressure if the tank is completely filled.

Portable Fuel Tank Placement in the Boat

Place the fuel tank in the boat so the vent is higher than the fuel level under normal boat operating conditions.

Low Permeation Fuel Hose Requirement

Required for outboards manufactured for sale, sold, or offered for sale in the United States.

FUEL AND OIL

- The Environmental Protection Agency (EPA) requires that any outboard manufactured after January 1, 2009, must use low permeation fuel hose for the primary fuel hose connecting the fuel tank to the outboard.
- Low permeation hose is USCG Type B1-15 or Type A1-15, defined as not exceeding 15 g/m²/24 h with CE 10 fuel at 23 °C as specified in SAE J 1527 - marine fuel hose.

Quick-Disconnect Fuel Hose Fitting

⚠ WARNING

Fuel is flammable and explosive. Ensure that the key switch is OFF and the lanyard is positioned so that the engine cannot start. Do not smoke or allow sources of spark or open flame in the area while servicing. Keep the work area well ventilated and avoid prolonged exposure to vapors. Always check for leaks before attempting to start the engine, and wipe up any spilled fuel immediately.

IMPORTANT: The fuel line quick-disconnect fuel hose fitting is not equipped with a check valve. Fuel will be present at the connection and may drain from the hose when disconnected.

- Ensure there is a suitable container ready when disconnecting the fuel line from the engine.
- Follow all fuel handling safety precautions.
- Wipe up spilled fuel and dispose of according to local laws and regulation.

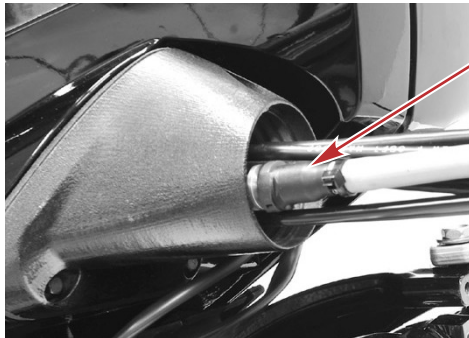

53883

Quick-disconnect fuel hose fitting

Engine Oil Recommendations—Standard and Pro XS Models

IMPORTANT: The use of nondetergent oils, multiviscosity oils (other than Mercury or Quicksilver NMMA FC-W certified oil or a major brand NMMA FC-W certified oil), full synthetic oils, low quality oils, or oils that contain solid additives is not recommended.

FUEL AND OIL

Mercury or Quicksilver NMMA FC-W or NMMA FC-W catalyst compatible certified SAE 10W-30 Marine 4-Stroke Engine Oil is recommended for general all-temperature use.

As an optional choice, Mercury or Quicksilver SAE 25W-40 Mineral Marine 4-Stroke Engine Oil or SAE 25W-40 Synthetic Blend Marine 4-Stroke engine oil may be used.

If the recommended Mercury or Quicksilver NMMA FC-W certified oils are not available, a major outboard manufacturer's brand of NMMA FC-W certified 4-Stroke outboard oil of similar viscosity may be used.

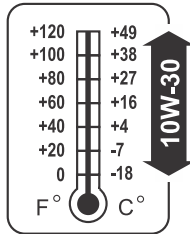

6.0 L (6.3 US qt)



60104

Engine Oil Recommendations—SeaPro Models

IMPORTANT: The use of nondetergent oils, multiviscosity oils (other than Mercury or Quicksilver NMMA FC-W certified oil or a major brand NMMA FC-W certified oil), full synthetic oils, low quality oils, or oils that contain solid additives are not recommended.

Mercury or Quicksilver NMMA FC-W or NMMA FC-W catalyst compatible certified SAE 25W-40 Mineral Marine 4-Stroke Engine Oil or SAE 25W-40 Synthetic Blend Marine 4-Stroke Engine Oil is recommended for general all-temperature use.

As an optional choice, Mercury or Quicksilver or SAE 10W-30 Marine 4-Stroke Engine Oil may be used when temperatures are 0 °C (32 °F) or less.

FUEL AND OIL

If the recommended Mercury or Quicksilver NMMA FC-W certified oils are not available, a major outboard manufacturer's brand of NMMA FC-W certified 4-Stroke outboard oil of similar viscosity may be used.

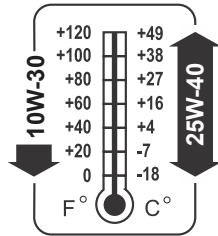

6.0 L (6.3 US qt)



60105

Checking and Adding Engine Oil

IMPORTANT: Do not overfill. For accurate readings, check the oil only when the engine is cold or after the engine has not run for at least an hour.

1. Tilt the outboard out/up past vertical to allow trapped oil to drain back to the oil sump. Allow the outboard to remain tilted for approximately one minute.
2. Tilt the outboard to its vertical operating position.
3. Remove the top cowl.
4. Pull out the dipstick. Wipe the dipstick end with a clean rag or towel and push the dipstick back in all the way.

IMPORTANT: Inspect oil for signs of contamination. Oil contaminated with water will have a milky color to it. Oil contaminated with fuel will have a strong fuel smell. If contaminated oil is noticed, have the engine checked by a Mercury Marine authorized dealer.

FUEL AND OIL

5. Pull the dipstick out again and observe the oil level. Oil should be in the operating range (between the top bar and bottom bar).

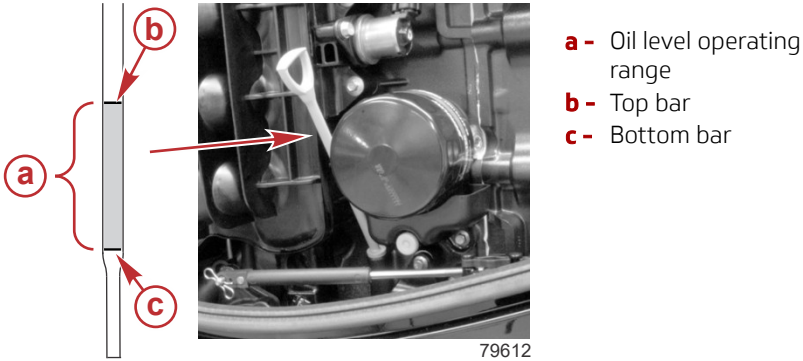

IMPORTANT: Do not try to fill the oil level to the top bar. Oil level is correct as long as it appears in the operating range.

6. If the oil level is below the bottom bar:
 - a. Remove the oil filler cap and add approximately 500 ml (16 oz) of the specified outboard motor oil.

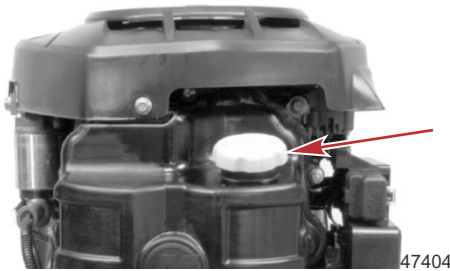

- b. Allow a few minutes for the oil to drain to the oil sump and recheck the dipstick.
 - c. If necessary, add additional oil to bring the oil level within the upper 1/3 level of the operating range. Avoid overfilling. Do not try to fill the oil level to the top bar.
7. Push the dipstick back in all the way.
 8. Install the oil fill cap hand-tight.
 9. Install the top cowl.

FEATURES AND CONTROLS

Remote Control Features

The following image highlights the features of some common Mercury Precision and Quicksilver remote controls.

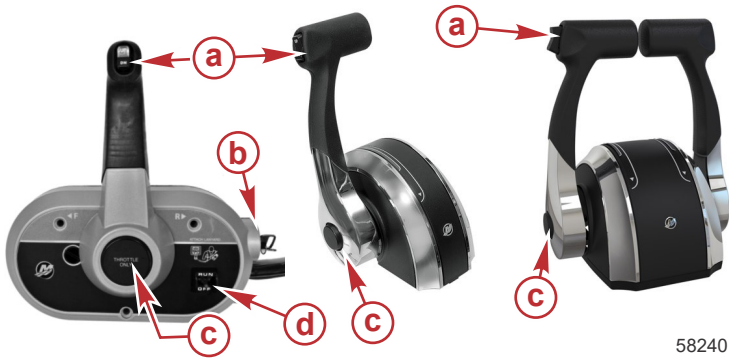

- a** - Trim/tilt switch – Refer to **Power Trim and Tilt**
- b** - Ignition key switch – **OFF, ON, START**
- c** - Throttle only button – Refer to **Operation – Starting the Engine**
- d** - Safety lanyard switch

For other controls, consult the boat dealer for a description of the functions and operations of the remote control.

Warning System

Warning Horn Signals

When the key switch is turned to the **ON** position, the warning horn will sound briefly to indicate it is functional. This is normal.

There are two types of warning horn signals to alert the operator of an active problem within the engine's operating system.

1. **Continuous six second beep:** Indicates a critical engine condition. Depending on the condition, the Engine Guardian system may engage and protect the engine by limiting its power. Return to port immediately and contact an authorized dealer.
2. **Intermittent short beeps for six seconds:** Indicates a noncritical engine condition. This condition does not require immediate attention. Continue boating. Depending on the nature of the problem, however, the engine's power may be limited by the Engine Guardian system to protect the engine (refer to **Engine Guardian System**). Contact an authorized dealer at the first convenience.

It is important to note that in either of the preceding scenarios, the horn will sound only one time. The horn signal will sound again upon shut down and restart, if the fault that triggered the signal is still present.

FEATURES AND CONTROLS

A few of the noncritical conditions indicated by the intermittent short beeps for six seconds can be corrected by the operator. These operator correctable conditions are as follows:

- Water in the boat-mounted water-separating fuel filter (optional accessory). Refer to the instructions supplied with the accessory kit.
- Cooling system (water pressure or engine temperature) problem. Stop the engine and check the water intake holes in the lower unit for obstruction.
- Low engine oil level. Refer to **Fuel and Oil – Checking and Adding Engine Oil**.

Engine Guardian System

The Engine Guardian system monitors the critical sensors on the engine for any early indications of problems. Engine Guardian is functional whenever the engine is operating, so there is never a concern about whether or not the engine is protected. The system will respond to a problem by sounding the warning horn for six seconds or reducing engine power in order to provide engine protection.

- If Engine Guardian has been activated, reduce the engine speed.
- The system must be reset before the engine will operate at higher speeds. Moving the throttle lever back to the idle position will reset the Engine Guardian system.
- If the Engine Guardian system determines that the reset has not corrected the problem, Engine Guardian will remain activated, continuing to limit the throttle. The problem must be corrected before Engine Guardian will allow the engine to reach a normal operating speed.

Overspeed Rev Limit

The overspeed rev limit is set at an RPM greater than the operating range. In the event that the engine is operated at an RPM greater than or equal to the overspeed limit, the PCM does not allow the engine to maintain the power requested by the operator. Refer to **Specifications** to determine this engine's RPM limit.

Upon reaching the beginning of the rev limit, Engine Guardian will cut-out the ignition to specific cylinders. If the operator does not reduce engine speed, Engine Guardian will cut-out the ignition to all the cylinders. There is no audible warning while Engine Guardian overspeed limit is active.

To reset the Engine Guardian protection:

1. Completely reduce the throttle for three seconds.
2. Engage the throttle. If the engine does not respond, repeat step one.

FEATURES AND CONTROLS

SmartCraft Product

A Mercury SmartCraft System instrument package can be purchased for this outboard. A few of the functions the instrument package will display are engine RPM, coolant temperature, oil pressure, water pressure, battery voltage, fuel consumption, and engine operating hours.

The SmartCraft instrument package will also aid in Engine Guardian diagnostics. The SmartCraft instrument package will display critical engine alarm data and potential problems.

Power Trim and Tilt

The outboard has a trim/tilt control called power trim. This enables the operator to easily adjust the position of the outboard by pressing the trim switch. Moving the outboard in closer to the boat transom is called trimming in or down. Moving the outboard further away from the boat transom is called trimming out or up.

Trim refers to the adjustment of the outboard within the first 20° range of travel. This is the range used while operating the boat on plane.

Tilt refers to adjusting the outboard further up and out of the water. With the engine turned off and ignition switch turned on, the outboard can be tilted out of the water. At low idle speed, the outboard can also be tilted up past the trim range to permit, for example, shallow water operation.

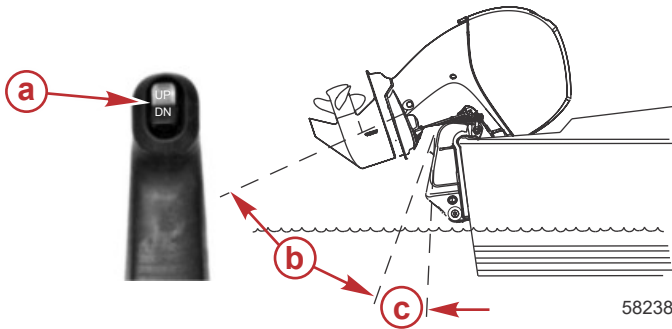

- a** - Trim switch
- b** - Tilt range
- c** - Trim range

FEATURES AND CONTROLS

Power Trim Operation

⚠ WARNING

Trimming the outboard beyond a neutral steering condition may result in a pull on the steering wheel or tiller handle and loss of boat control. Maintain control of the boat if trimming beyond a neutral steering condition.

Typically, operating around the middle of the trim range will give satisfactory results. In certain situations, trimming the outboard all the way in or out will improve performance, but not without side effects.

The most significant side effect of changing the trim away from the middle of the range is a pull or torque that can be felt on the steering wheel or tiller handle. This steering torque results from the propeller shaft no longer being parallel to the water surface.

⚠ WARNING

Operating the boat at high speeds with the outboard trimmed too far under can create excessive bow steer, resulting in the operator losing control of the boat. Install the trim limit pin in a position that prevents excessive trim under and operate the boat in a safe manner.

Refer to **Outboard Operating Angle Considerations** for the benefits and detriments of changing the trim angle either in or out from the middle of the range.

Outboard Operating Angle Considerations

Before adjusting the outboard operating angle from the middle of the range, consider the following benefits and detriments of changing the angle.

Adjusting the outboard close to the boat transom (down or in) can:

- Lower the bow.
- Result in quicker planing off, especially with a heavy load or a stern heavy boat.
- Generally improve the ride in choppy water.
- Increase steering torque or pull to the right (with the normal right-hand rotation propeller).
- In excess, lower the bow of some boats to a point where they begin to plow with their bow in the water while on plane. This can result in an unexpected turn in either direction (called bow steering or oversteering), if any turn is attempted or if a significant wave is encountered.

Adjusting the outboard away from the boat transom (out or up) can:

- Lift the bow out of the water
- Generally increase top speed
- Increase clearance over submerged objects or a shallow bottom

FEATURES AND CONTROLS

- Increase steering torque or pull to the left at a normal installation height (with the normal right-hand rotation propeller)
- Cause engine overheating if any cooling water intake holes are above the waterline
- In excess, cause boat porpoising (bouncing) or propeller ventilation

Tilting Operation

To tilt the outboard, shut off the engine and press the trim/tilt switch or auxiliary tilt switch to the up position. The outboard will tilt up until the switch is released or it reaches its maximum tilt position.

Tilt Support Lever

The hydraulic system used for power trim and tilt will not maintain an outboard's tilt over sustained periods. The tilt support lever prevents a tilted outboard from slowly creeping back down.

To engage the tilt support lever:

- Tilt the outboard up.
- Rotate the knob to bring the support lever upward.
- Lower the outboard to rest on the tilt support lever.

To disengage the tilt support lever:

- Tilt the outboard up slightly.
- Rotate the knob to bring the support lever down.
- Lower the outboard.

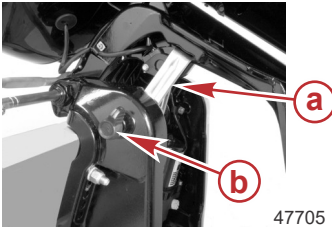

- a** - Tilt support lever
- b** - Knob

Manual Tilting

If the outboard cannot be tilted using the power trim/tilt switch, the outboard can be manually tilted.

NOTE: *The manual tilt release valve must be tightened before operating the outboard to prevent the outboard from tilting up during reverse operation.*

To manually tilt the outboard:

1. Turn out the manual tilt release valve three turns counterclockwise.
2. Tilt the outboard to the desired position

FEATURES AND CONTROLS

3. Tighten the manual tilt release valve.

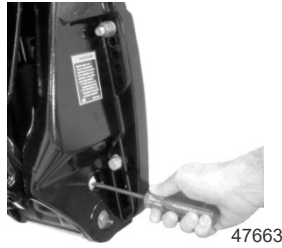

Auxiliary Tilt Switch

This switch can be used to tilt the outboard up or down using the power trim system.



a - Auxiliary tilt switch

Trim Tab Adjustment

Propeller steering torque may cause a boat to pull in one direction. Steering torque normally occurs at or above planing speeds. Higher speed causes higher steering torque loads. The trim tab can compensate for normal steering torque in many cases and can be adjusted within limits to reduce any unequal steering effort.

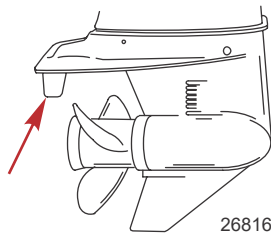

NOTE: Trim tab adjustment will have little effect reducing steering torque if the outboard is installed with the anti-ventilation plate approximately 50 mm (2 in.) or more above the boat bottom.

Operate the boat at normal cruising speed and trim position. Turn the boat left and right and note the direction the boat turns more easily.

FEATURES AND CONTROLS

Making Adjustments

NOTE: *If adjustment is necessary, make small adjustments at a time.*

1. Loosen the trim tab fastener.
2. Make only a small adjustment.
 - If the boat turns more easily to the left, move the trailing edge of the trim tab to the left.
 - If the boat turns more easily to the right, move the trailing edge of the trim tab to the right.
3. Tighten the fastener and test. If steering torque is still evident, repeat the process.

FEATURES AND CONTROLS

Notes:

OPERATION

Engine Break-in Procedure

IMPORTANT: Failure to follow the engine break-in procedures can result in poor performance throughout the life of the engine and can cause engine damage. Always follow break-in procedures.

1. For the first two hours of operation, run the engine at varied throttle settings up to 4500 RPM or three-quarter throttle. Changes in throttle should be gradual and extended time at idle should be avoided.
2. For the next eight hours of operation, avoid continuous operation at full throttle for more than five minutes at a time.

Important Daily Inspection Before Each Use

Any outboard mounted on the boat must have the mounting hardware inspected and checked to ensure that the hardware has not become loose. A decal on the transom bracket reminds the operator to check the fasteners securing the outboard to the transom before each use.

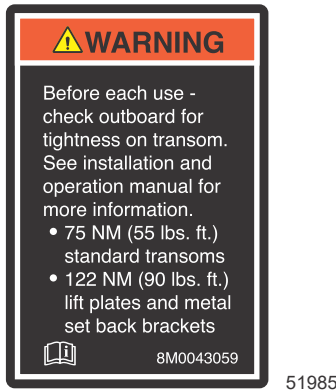

Decal on the transom bracket

Prestarting Checklist

Before starting the outboard:

- Review the **Safe Boating Recommendations** in the **Important Safety Information** section of this manual.
- Perform all additional daily inspections and checks listed in **Maintenance - Inspection and Maintenance Schedule**.
- If the engine has less than 10 hours of operation, review the **Engine Break-in Procedure**.
- Ensure that the fuel supply is OK.

OPERATION

Starting the Engine

NOTICE

Without sufficient cooling water, the engine, the water pump, and other components will overheat and suffer damage. Provide a sufficient supply of water to the water inlets during operation.

Before starting, read the **Prestarting Checklist**.

1. Check the engine oil level.

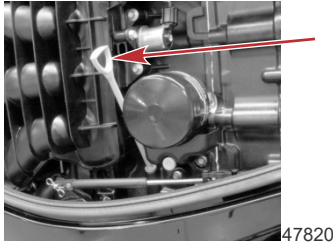

2. Ensure that the cooling water intake is submerged.

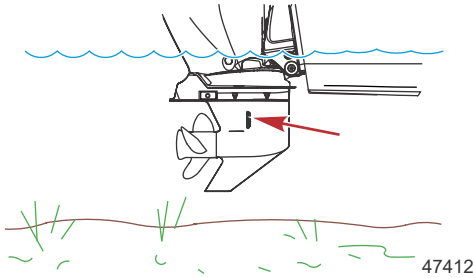

3. Open the fuel tank vent screw (in the filler cap) on manual venting type fuel tanks.

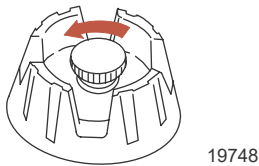

OPERATION

4. Set the lanyard stop switch to the **RUN** position. Refer to **Important Safety Information - Lanyard Stop Switch**.



19791

Lanyard stop switch appearance may vary

5. Shift the outboard to the neutral (N) position.



58237

6. For initial start of a new engine or for an engine that ran out of fuel or was drained of fuel, turn the ignition key switch to the **ON** position for approximately five seconds.
7. Turn the ignition key to **START**, and release the key.
 - The electronic starting system will automatically crank the engine for starting.
 - If the engine fails to start, the engine will stop cranking.
 - The engine may start, run rough, and stall while filling the fuel system.
 - Repeat this step until the engine starts.

NOTE: Allow the starter motor to cool for 20–30 seconds between start attempts.

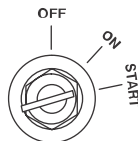

19804

8. After the engine starts, check for a steady stream of water flowing out of the water pump indicator hole.

IMPORTANT: If no water is coming out of the water pump indicator hole:

- a. Immediately STOP the engine.

OPERATION

- b. Check the cooling water intake for obstruction. If no obstruction is found:
 - There may be a blockage within the cooling system.
 - The water pump may have failed.
 - Either of these conditions will cause the engine to overheat, resulting in engine damage.
 - Have the outboard checked by a Mercury Marine authorized dealer.
9. If the engine does not start:
 - a. Push in the throttle-only button, and advance the remote control handle slightly to open the throttle.



- b. Turn the ignition key, and be prepared to immediately reduce the throttle after the engine has started.

Warming Up the Engine

Before beginning operation, allow the engine to warm up at idling speed for three minutes.

Gear Shifting

IMPORTANT: Observe the following:

- **Never shift the outboard into or out of gear unless the engine speed is at idle. Shifting at higher than engine idle speed could cause damage to the gearcase.**
- **Do not shift the outboard into reverse when the forward motion of the boat is greater than a no wake speed. Shifting into reverse at higher boat speeds could cause the engine to stall, and in some situations, this could cause water to be drawn into the cylinders, resulting in severe engine damage.**
- **Do not shift the outboard into reverse when the engine is not running. Damage to the shift linkage could occur.**
- The outboard has three gear shift positions: forward (F), neutral (N), and reverse (R).

OPERATION

- When shifting, always stop at the neutral position and allow the engine idle speed to stabilize before shifting into another gear.
- Always shift the outboard into gear with a quick motion.
- After shifting the outboard into gear, advance the lever further to increase speed.



Stopping the Engine

1. Reduce the engine speed.
2. Shift the outboard into neutral.
3. Turn the ignition key to the **OFF** position.

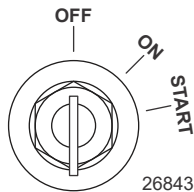

Operating at High Elevations

Mercury Marine engines automatically compensate for high elevation changes, but there will still be some performance loss, due to the reduced oxygen in the air. A different pitch propeller may help reduce this normal performance loss. Consult an authorized dealer.

Operating in Freezing Temperatures

When an outboard is used or moored in freezing or near freezing temperatures, keep the outboard tilted down, with the gearcase submerged. This prevents any water trapped in the gearcase from freezing and causing possible damage to the water pump and other components.

If there is a chance of ice forming on the water, the outboard should be removed from and completely drained of water, immediately after use. If ice should form inside the outboard driveshaft housing, the ice will block water flow to the engine, causing possible damage.

OPERATION

Operating in Saltwater or Polluted Water

Flush the outboard's internal water passages with fresh water after each use in salty or polluted water. This will prevent a buildup of deposits from clogging the water passages. Refer to **Maintenance - Flushing the Cooling System**.

If the boat is kept moored in the water, always (except in freezing temperatures) tilt the outboard up so the gearcase is completely out of water when not in use.

Wash the outboard exterior (Refer to **Maintenance - Cleaning Care Recommendations**) and flush out the exhaust outlet of the propeller and gearcase with fresh water after each use.

Each month, spray Mercury Precision or Quicksilver Corrosion Guard on external metal surfaces. Exercise care to not spray the corrosion control anodes, as this will reduce the anodes' effectiveness.

Description	Where Used	Part No.
Corrosion Guard	External metal surfaces	92-802878 55

Operating in Shallow Water

NOTICE

Operating the engine with the outboard in the tilt range can damage the engine or the transom. If operating the engine in the tilt range, such as in shallow water, do not exceed 2000 RPM.

When operating a boat in shallow water, the outboard can be tilted beyond the maximum trim range to prevent hitting bottom.

1. Reduce the engine speed below 2000 RPM.
2. Tilt the outboard up. Make sure all the cooling water intake holes stay submerged at all times.
3. Operate the engine at slow speed only (below 2000 RPM).

Tilt Circuit Preset Pressure Limit

When operating the outboard above the trim range, the outboard will automatically return to the maximum trim range, if the applied thrust force exceeds the preset pressure limit of the tilt circuit. The tilt circuit preset pressure limit can be exceeded at approximate engine speeds of 1500–2000 RPM. The following variables directly affect at which engine speed the pressure limit will be exceeded:

- Outboard shaft length
- Gearcase type
- Weight of the load in the boat
- Propeller pitch

OPERATION

Setting Trim Angle at Idle Speed

When idling, a portion of the engine's exhaust is ported through the idle relief muffler. If the engine is trimmed too far in, it is possible for the relief hole to be below the surface of the water. Always ensure that the relief hole is above the waterline, whenever the engine is at idle.

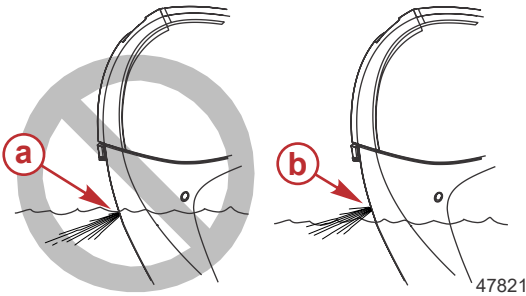

- a** - Relief hole submerged (wrong)
- b** - Relief hole above waterline (correct)

Fuel Supply Module Priming Procedure

The fuel supply module (FSM) is not vented to the ambient air. The air trapped in the FSM, fuel lines, and fuel rail, will be slightly compressed during the initial ignition key on with a dry or drained fuel system. Additional key on events under these conditions will not compress the air further to finish the priming of the FSM. Excessive number of key on events may eventually damage the fuel pumps. The volume of air trapped in the FSM must be purged to prime the fuel system. This can be achieved by connecting a tool to the fuel rail Schrader valve fitting to quickly purge the system into an approved container, or by cranking the engine.

- The use of a purge tool for priming the FSM is the preferred method, but is not always practical.
- If a primer bulb is installed, it can be used during the priming event to shorten the amount of time required to start the engine.

Priming the FSM with a Fuel Pressure Gauge

This method should be used on boats where the fuel inlet system to the outboard is restrictive; contains an anti-siphon valve or holds a relatively large volume of fuel because of a long fuel supply line or water-separating fuel filter. The objective is to purge the air entrained in the fuel system through a purge tool connected to the fuel rail Schrader valve test port. During the key on, opening the dump valve will allow the air to be purged from the FSM and fuel rail.

1. Verify the engine is in a level vertical position.
2. Verify the boat's fuel supply line is connected to the outboard fuel system inlet fitting.
3. Connect a fuel pressure gauge to the fuel rail Schrader valve.

OPERATION

Fuel Pressure Gauge Kit

91-881833A03

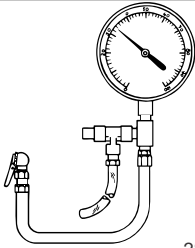

Tests the fuel pump pressure; can be used to relieve fuel pressure.

- Secure the fuel pressure gauge purge hose into an appropriate fuel container to collect excess fuel.

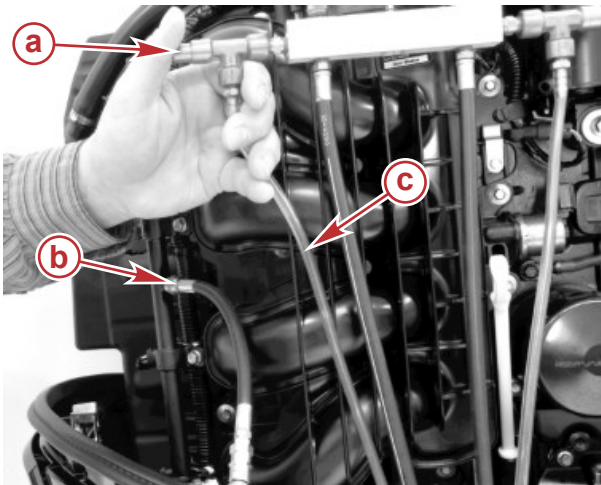

58370

- a** - Fuel pressure gauge purge valve
- b** - Schrader valve
- c** - Purge hose to appropriate container

- Open the fuel pressure gauge purge valve and turn the ignition key on. The fuel pumps will run for approximately three to five seconds.
- Turn the ignition key off and then on.
 - The fuel pumps will run for approximately three to five seconds.
 - Continue this ignition key cycle until the purged fuel is relatively clear of air bubbles.

NOTE: If the outboard fuel system does not prime within 15 key on events, check for leaks in the fuel supply line to the outboard. Repair as needed. If no leak is found, the fuel supply system to the outboard may be too restrictive. Correct the condition and try again.

OPERATION

7. Remove the fuel pressure gauge.
8. Turn the ignition key on. When the fuel pumps stop running, start the engine.
 - The engine may not start on the first attempt.
 - The engine will run rough at idle for up to two minutes while the residual air is purged from the fuel system.

Priming the FSM (Ran out of Fuel Condition)

When the boat's fuel system is void of fuel volume, it can be primed without the use of a purge tool. This method can be used on boats where the fuel inlet system to the outboard is less restrictive and holds a relatively small volume of fuel; a short fuel supply line, no water-separating fuel filter, or a water-separating fuel filter is already primed. The objective is to purge the air entrained in the fuel system through the fuel injectors during engine cranking to allow fuel to enter the fuel module.

1. Verify the engine is in a level vertical position.
2. Verify the boat's fuel supply line is connected to the outboard fuel system inlet fitting.
3. Turn the ignition key on. The fuel pumps will run for approximately three to five seconds.
4. Turn the ignition key to the **START** position and release the key. The ECM controls the activation of the starter. The starter may continue cranking for up to eight seconds.

NOTE: When priming a drained fuel system, residual fuel may cause the engine to flare and stall which shortens the engine cranking event.

IMPORTANT: Allow the starter motor to cool for 20 to 30 seconds between full eight second crank events. Limit the number of events to a maximum of 10 full eight second cranking events.

5. Continue with the ignition key on and start sequence until the engine continues to run.

NOTE: After the engine starts, it may run rough at idle for up to two minutes while the residual air is purged from the fuel system.

6. If the fuel system will not prime within 10 full eight-second cranking events, use the **Priming the FSM with a Fuel Pressure Gauge** procedure to prime the fuel system.

OPERATION

Notes:

MAINTENANCE

EPA Emissions Regulations

All new outboards manufactured by Mercury Marine are certified to the United States Environmental Protection Agency, as conforming to the requirements of the regulations for the control of air pollution from new outboard motors. This certification is contingent on certain adjustments set to factory standards. For this reason, the factory procedure for servicing the product must be strictly followed and, wherever practicable, returned to the original intent of the design. **Maintenance, replacement, or repair of the emission control devices and systems may be performed by any marine spark ignition (SI) engine repair establishment or individual.**

Emission Certification Label

An emission certification label, showing emission levels and engine specifications directly related to emissions, is placed on the engine at the time of manufacture.

The diagram shows an emission certification label with the Mercury logo and the title "EMISSION CONTROL INFORMATION". The label contains the following text and fields:

- THIS ENGINE CONFORMS TO CALIFORNIA AND U.S. EPA EMISSION REGULATIONS FOR SPARK IGNITION MARINE ENGINES
- REFER TO OWNERS MANUAL FOR REQUIRED MAINTENANCE SPECIFICATIONS AND ADJUSTMENTS
- IDLE SPEED (in gear): L H
- FAMILY:
- hp L g/kWh
- kw CO FEL: g/kWh
- SPARK PLUG:
- GAP:
- LOW PERM/HIGH PERM:

Callouts a-j point to the following fields:

- a - Idle speed
- b - Engine horsepower
- c - Piston displacement
- d - Engine power - kilowatts
- e - Date of manufacture
- f - US EPA engine family name
- g - Regulated emission limit for the engine family
- h - Regulated emission limit for the engine family
- i - Recommended spark plug and gap
- j - Percent of fuel line permeation

43210

- a** - Idle speed
- b** - Engine horsepower
- c** - Piston displacement
- d** - Engine power - kilowatts
- e** - Date of manufacture
- f** - US EPA engine family name
- g** - Regulated emission limit for the engine family
- h** - Regulated emission limit for the engine family
- i** - Recommended spark plug and gap
- j** - Percent of fuel line permeation

Owner Responsibility

The owner/operator is required to have routine engine maintenance performed to maintain emission levels within prescribed certification standards.

The owner/operator is not to modify the engine in any manner that would alter the horsepower or allow emission levels to exceed their predetermined factory specifications.

MAINTENANCE

Cleaning Care Recommendations

Outboard Care

To keep the outboard in the best operating condition, it is important that it receives the periodic inspections and maintenance listed in the **Inspection and Maintenance Schedule**. Proper maintenance helps ensure the safety of the operator and passengers and retains the engine's dependability.

Record all maintenance performed in the **Maintenance Log** at the back of this book. Save all maintenance work orders and receipts.

Selecting Outboard Replacement Parts

For best results, use only original Mercury Precision or Quicksilver replacement parts and Genuine Lubricants.

Do Not Use Caustic Cleaning Chemicals

IMPORTANT: Do not use caustic cleaning chemicals on the outboard power package. Some cleaning products contain strong caustic agents such as hull cleaners with hydrochloric acid. These cleaners can degrade some of the components they come in contact with including critical steering fasteners.

Damage to steering fasteners may not be obvious during visual inspection and this damage may lead to catastrophic failure. Some caustic cleaning chemicals may cause or accelerate corrosion. Exercise caution when using cleaning chemicals around the engine and follow the recommendations on the packaging of the cleaning product.

Cleaning Gauges

IMPORTANT: Never use high-pressure water to clean gauges.

Routine cleaning of the gauges is recommended to prevent a buildup of salt and other environmental debris. Crystalized salt can scratch the gauge display lens when using a dry or damp cloth. Ensure that the cloth has a sufficient amount of fresh water to dissolve and remove salt or mineral deposits. Do not apply aggressive pressure on the display lens while cleaning.

When water marks cannot be removed with a damp cloth, mix a 50/50 solution of warm water and isopropyl alcohol to clean the display lens. **Do not** use acetone, mineral spirits, turpentine type solvents, or ammonia based cleaning products. The use of strong solvents or detergents may damage the coating, the plastics, or the rubber keys on the gauges.

If the gauge has a sun cover available, install the cover when the unit is not in use to prevent UV damage to the plastic bezels and rubber keys.

Cleaning Remote Controls

IMPORTANT: Never use high-pressure water to clean remote controls.

MAINTENANCE

Routine cleaning of the remote control external surfaces is recommended to prevent a buildup of salt and other environmental debris. Use a cloth towel that has a sufficient amount of fresh water to dissolve and remove salt or mineral deposits.

When water marks cannot be removed with a damp cloth, mix a 50/50 solution of warm water and isopropyl alcohol to clean the remote control. **Do not** use acetone, mineral spirits, turpentine type solvents, or ammonia based cleaning products. The use of strong solvents or detergents may damage the coating, the plastics, or the rubber components on the remote control.

Cleaning Care for Top and Bottom Cowls

IMPORTANT: Dry wiping (wiping the plastic surface when it is dry) will result in minor surface scratches. Always wet the surface before cleaning. Do not use detergents containing hydrochloric acid. Follow the cleaning and waxing procedure.

Cleaning and Waxing Procedure

1. Before washing, rinse the cowls with clean water to remove dirt and dust that may scratch the surface.
2. Wash the cowls with clean water and a mild nonabrasive soap. Use a soft clean cloth when washing.
3. Dry thoroughly with a soft clean cloth.
4. Wax the surface using a nonabrasive automotive polish (polish designed for clear coat finishes). Remove the applied wax by hand using a clean soft cloth.
5. To remove minor scratches, use Mercury Marine Cowl Finishing Compound (92-859026K 1).

IMPORTANT: Do not rinse the cowls with water when the outboard is in a tilted position, as this could allow water to enter the air intakes (if equipped). Always lower the outboard to a vertical position prior to rinsing the cowls.

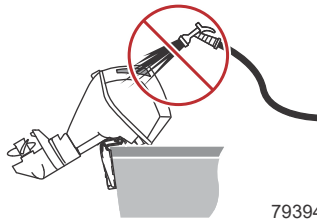

79394

Cleaning Care for the Powerhead (Saltwater Use)

If the outboard is operated in saltwater, remove the top cowl and flywheel cover. Inspect the powerhead and powerhead components for salt buildup. Wash off any salt buildup from the powerhead and powerhead components with fresh water. Keep water spray out of the air intake and alternator.

MAINTENANCE

After washing, allow the powerhead and components to dry. Apply Quicksilver or Mercury Precision Lubricants Corrosion Guard spray on the external metal surfaces of the powerhead and powerhead components. Do not allow the Corrosion Guard spray to come in contact with the alternator drive belt or belt pulleys.

IMPORTANT: Do not allow lubricant or Corrosion Guard spray to come in contact with the alternator drive belt or the belt pulleys. The alternator drive belt could slip and be damaged if it becomes coated with any lubricant or Corrosion Guard spray.

Description	Where Used	Part No.
Corrosion Guard	External metal surfaces of the powerhead and powerhead components.	92-802878 55

Top Cowl Removal and Installation

Removal

Unlock the top cowl by pulling out on the rear cowl latch. Lift the top cowl off the engine.

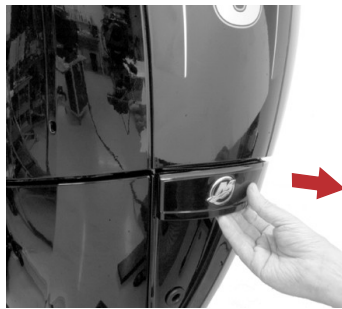

47632

Installation

1. Lower the top cowl over the engine.
2. Bring the front of the cowl down first and engage the front cowl hook.

MAINTENANCE

3. Lower the cowl into the seated position and apply pressure to the back of the cowl to lock it in place.



4. Ensure that the cowl is securely fastened by trying to pull up on the back of the cowl.

Inspection and Maintenance Schedule

Refer to the tables below for proper inspection and maintenance intervals.









Before Each Use
Check that the lanyard stop switch stops the engine. Refer to Important Safety Information - Lanyard Stop Switch .
Check the engine oil level. Refer to Fuel and Oil - Checking and Adding Engine Oil .
Inspect the fuel system for leaks. Refer to Fuel System .
Inspect the tightness on transom. Refer to Transom Tightness Inspection .
Check the propeller for damage.
Check the steering system for binding or loose components.
Inspect the hydraulic steering fittings and hoses for leaks or damage, if equipped.
Inspect the power steering fluid level, if equipped.

After Each Use
Flush the outboard cooling system if operating in salty, polluted, or muddy water. Refer to Flushing the Cooling System .
If operating in saltwater, inspect the powerhead and powerhead components for salt buildup. Refer to Cleaning Care for the Powerhead (Saltwater Use) .
If operating in saltwater, wash off all salt deposits and flush out the exhaust outlet of the propeller and gearcase with fresh water.

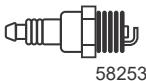
MAINTENANCE

100 Hour Maintenance (Every 100 Hours of Use or Once Yearly, Whichever Occurs First)	Dealer Item
Change the engine oil and filter. Refer to Engine Oil and Filter . Change more frequently when the engine is operated under adverse conditions, such as extended trolling.	
Change the gearcase lubricant. Refer to Gearcase Lubrication .	
Inspect the corrosion control anodes. Refer to Corrosion Control Anodes . Check more frequently when used in saltwater.	
Check the low-pressure fuel filter for contaminants. Replace the filter if required. Refer to Low-Pressure Fuel Filter .	
Remove the propeller and lubricate the propeller shaft. Refer to Propeller Replacement .	
Inspect the condition of propeller bore sleeve when the propeller is removed. Refer to Propeller Bore Sleeve Inspection—If Equipped .	
Inspect the engine starting battery. Refer to Battery Inspection .	
Saltwater usage: Remove and inspect spark plugs for corrosion and replace as necessary. Apply Anti-Seize Compound only on threads of spark plug prior to installation. Refer to Spark Plug Inspection and Replacement .	
Add Quickleen to the fuel tank. Refer to Fuel and Oil - Fuel Additives .	
Check cowl seals to ensure seals are intact and not damaged.	
Check internal cowl sound reduction foam to ensure foam is intact and not damaged, if equipped.	
Check that the intake silencer is in place, if equipped.	
Check that the idle relief muffler is in place, if equipped.	
Check for loose hose clamps and rubber boots on the air intake assembly, if equipped.	
Inspect the thermostat for corrosion or a broken spring. Ensure that the thermostat closes completely at room temperature.	X
Check the outboard mounting fasteners that fasten the outboard to the boat transom. Tighten the fasteners to the specified torque.	X
Check tightness of bolts, nuts, and other fasteners.	X
Grease shift shaft drag link joint.	X
300 Hour Maintenance (Every 300 Hours of Use or Three Years, Whichever Occurs First)	Dealer Item
Check the power trim fluid level. Refer to Checking Power Trim Fluid .	
Lubricate all lubrication points. Refer to Lubrication Points . Lubricate more frequently when used in saltwater.	

MAINTENANCE

Icon	Definition	Icon	Definition
 58251	Engine oil and filter	 58252	Gearcase lubricant
 58253	Spark plugs	 58254	Thermostat
 58255	Low pressure fuel filter	 58256	Anodes
 58257	Accessory drive belt	 58258	Water pump impeller

Battery Inspection

IMPORTANT: Read the safety and maintenance instructions that accompany the engine starting battery.

Inspect the battery at periodic intervals to ensure proper engine starting capability.

1. Verify the engine is off before inspecting the battery.
2. Ensure that the battery is secure against movement.
3. Verify that the battery cable terminals are clean, tight, and correctly installed on the battery (positive to positive and negative to negative).
4. Verify the battery is equipped with a nonconductive shield to prevent accidental shorting of battery terminals.

Flushing the Cooling System

Flush the internal water passages of the outboard with fresh water after each use in salty, polluted, or muddy water. This will help prevent a buildup of deposits from clogging the internal water passages.

1. With the engine turned off, place the outboard in either the operating position (vertical) or in a tilted position.
2. Remove the flush connector from the bottom cowl.

MAINTENANCE

3. Remove the cover from the flush connector and thread a water hose into the flush connector.

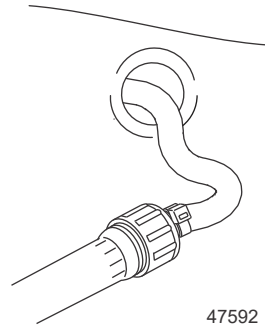
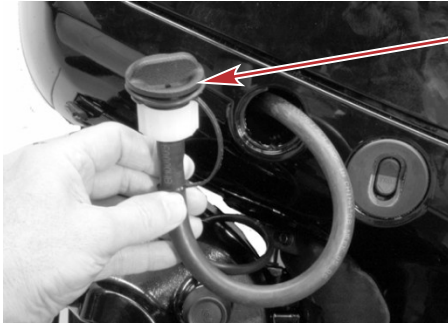

4. Turn on the water tap ($\frac{1}{2}$ maximum) and let the water flush through the cooling system for about 15 minutes.
5. When flushing is complete, turn off the water and disconnect the water hose.
6. Install the cover on the flush connector. Place the flush connector back into the bottom cowl.

Corrosion Control Anodes

The outboard has several corrosion control anodes. An anode helps protect the outboard against galvanic corrosion by sacrificing its metal to be slowly eroded instead of the outboard metals.

Each anode requires periodic inspection, especially in saltwater, which will accelerate the erosion. To maintain corrosion protection, always replace the anode before it is completely eroded. Never paint or apply a protective coating on the anode as doing so will reduce the effectiveness of the anode.

Two anodes are located on either side of the gearcase. A third anode is installed on the bottom of the transom bracket assembly.

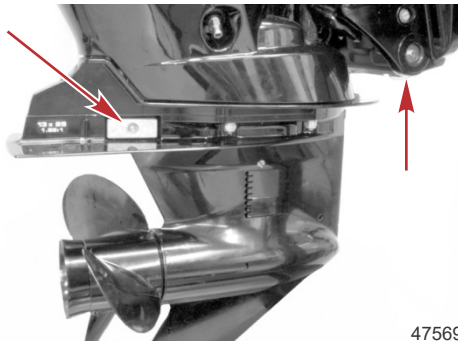

47569

MAINTENANCE

A fourth anode is located on the underside of the rear of the anti-ventilation plate.

Engine Oil and Filter

Oil Change Kits

Mercury Marine offers convenient oil change kits for several outboard models ranging from 9.9 hp to 150 hp. These kits contain a new filter, oil, and any additional parts required for a complete oil change. The kits are available in both Mercury Marine and Quicksilver brands. Refer to the following chart for details.

Models	Mercury P/N	Quicksilver P/N
9.9/15/20 hp EFI	8M0081914	8M0081910
15/20 hp carbureted	8M0081914	8M0081910
25/30 hp EFI	8M0081915	8M0081911
30/40/50/60 hp EFI (4-cyl)	8M0081916	8M0081912
1.7L 75/90/115 hp EFI	8M0081917	8M0081913
2.1L 75/90/115 hp	8M0107510	8M0107511
150 hp	8M0188357	8M0107513



Draining the Engine Oil

1. Tilt the outboard out/up past vertical and hold for approximately one minute, to allow any trapped oil to drain back to the oil sump.
2. Tilt the outboard to a vertical position.
3. Use a 16 mm (5/8 in.) wrench and loosen the oil drain valve so that it can be turned by hand. Be careful to not open the valve too far, allowing oil to drain.
4. Attach a 12 mm (7/16 in.) I.D. drain hose to the oil drain valve. Position the opposite end of the hose into an appropriate container.

IMPORTANT: Do not loosen the oil drain valve more than 2-1/2 turns out. The oil seal could get damaged beyond 2-1/2 turns.

MAINTENANCE

- Loosen the oil drain valve 2-1/2 turns to allow oil to drain. Do not exceed 2-1/2 turns.

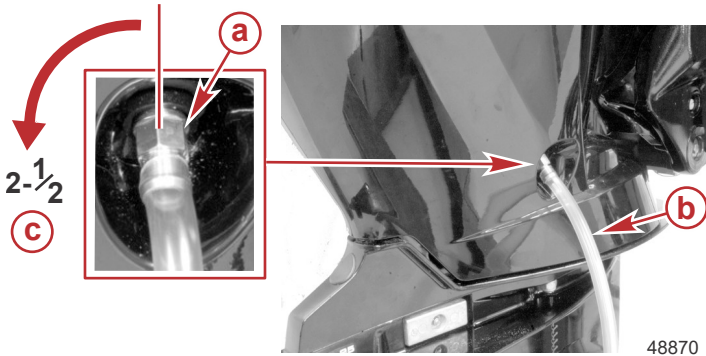

- a** - Oil drain valve
- b** - Drain hose
- c** - Loosen 2-1/2 turns maximum

- After the oil has drained, hand-tighten the oil drain valve (clockwise) and remove the oil drain hose.

IMPORTANT: Overtightening the oil drain valve can damage the oil sump.

- Tighten the oil drain valve to the specified torque.

Description	Nm	lb-in.	lb-ft
Oil drain valve	15	133	-

- Clean up any oil in the valve area.

Changing the Oil Filter

- Remove the plug from the oil trough, and attach a 12 mm (7/16 in.) I.D. drain hose to the fitting. Position the opposite end of the hose into an appropriate container.

MAINTENANCE

2. Remove the old filter by turning the filter counterclockwise.

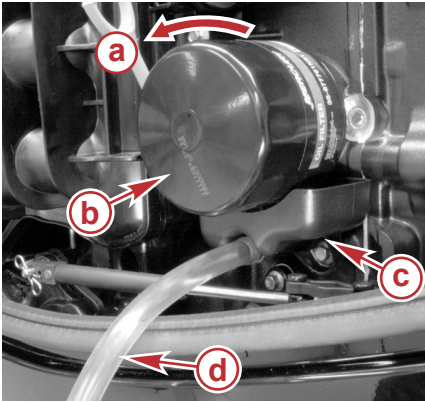

47562

- a** - Turn counterclockwise
- b** - Oil filter
- c** - Oil trough
- d** - Drain hose

3. Allow oil in the trough to drain, and remove the oil drain hose.
4. Clean any oil from the oil trough, and install the plug.
5. Clean the oil filter mounting base.
6. Apply a film of clean oil to the filter gasket. Do not use grease.
7. Screw a new filter on until the gasket contacts the base. Then tighten $\frac{3}{4}$ to 1 turn.

Filling the Crankcase with Oil

1. Remove the oil fill cap and add approximately 6 liters (6.3 US qt) of the recommended oil. This will bring the oil level within the midpoint of the operating range.

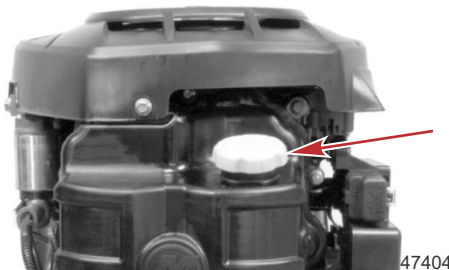

47404

2. Idle engine for five minutes and check for leaks.
3. Stop the engine.
4. For an accurate oil level reading, allow the engine to cool for at least an hour before checking the oil level. Refer to **Fuel and Oil - Checking and Adding Engine Oil**.

MAINTENANCE

NOTE: Checking the oil level within five minutes of engine shutdown can falsely read up to 1 liter (1 US qt) low. Allow the engine to cool for at least an hour before checking the oil level.

Fuel System

⚠ WARNING

Fuel is flammable and explosive. Ensure that the key switch is OFF and the lanyard is positioned so that the engine cannot start. Do not smoke or allow sources of spark or open flame in the area while servicing. Keep the work area well ventilated and avoid prolonged exposure to vapors. Always check for leaks before attempting to start the engine, and wipe up any spilled fuel immediately.

IMPORTANT: Use an approved container to collect and store fuel. Wipe up spilled fuel immediately. Material used to contain spilled fuel must be disposed of in an approved receptacle.

For service on any part of the fuel system:

1. **Before service work:** Stop the engine and disconnect the battery.
2. **During service work:** Perform fuel system service in a well-ventilated area.
3. **After service work:** Inspect all completed service work for signs of fuel leakage.

Fuel Line Inspection

Visually inspect the fuel line for cracks, swelling, leaks, hardness, or other signs of deterioration or damage. If any of these conditions are found, the fuel line must be replaced.

Low-Pressure Fuel Filter

The low-pressure filter can be serviced as a general maintenance item. Do not attempt service of the high-pressure filter, however; it should be serviced only by an authorized dealer.

Removal

1. Turn the ignition key switch to the **OFF** position.

MAINTENANCE

2. Move the lift handle so that the locking tab clears the bracket.

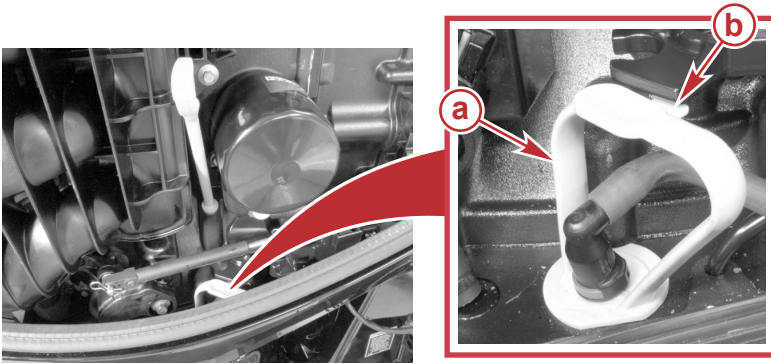

47535

- a** - Lift handle
- b** - Locking tab secured under bracket

3. Use the lift handle and pull the fuel filter out of its opening. If necessary, move the fuel hose so that it clears the bracket while lifting the fuel filter.
4. Push in on the fuel hose release tabs and disconnect the fuel hoses from the fuel filter.
5. Place the lower hose into the hose holder to prevent it from dropping into the filter hole.

MAINTENANCE

6. Remove the fuel filter from the lift handle.

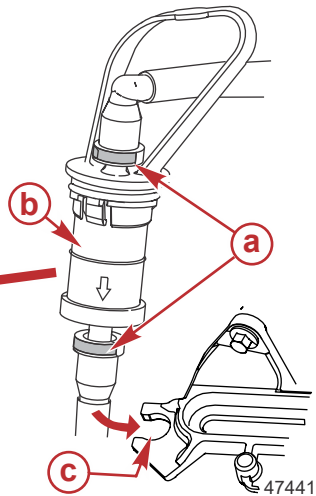
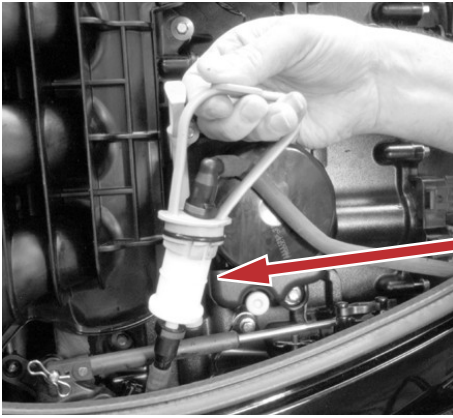

- a** - Fuel hose release tab
- b** - Low-pressure fuel filter
- c** - Hose holder

Installation

1. Place the lift handle onto the fuel filter. Install the new fuel filter so the arrow points toward the engine.
2. Connect the fuel hoses to the fuel filter securely with the locking hose connections.
3. Visually inspect for fuel leakage from the fuel filter while turning the ignition key to the **RUN** position, forcing fuel into the fuel filter. Repair any fuel leaks if necessary.
4. Install the fuel filter back into the opening. Position the lift handle so that the locking tab is secured under the bracket.

Gearcase Lubrication

When adding or changing gearcase lubricant, visually check for the presence of water in the lubricant. If water is present, it may have settled to the bottom and will drain out prior to the lubricant, or it may be mixed with the lubricant, giving it a milky colored appearance. If water is noticed, have the gearcase checked by an authorized dealer. Water in the lubricant may result in premature bearing failure or, in freezing temperatures, will turn to ice and damage the gearcase.

MAINTENANCE

Examine the drained gearcase lubricant for metal particles. A small amount of metal particles indicates normal gear wear. An excessive amount of metal filings or larger particles (chips) may indicate abnormal gear wear and should be checked by an authorized dealer.

Draining the Gearcase

1. Place the outboard in a vertical operating position.
2. Remove the propeller. Refer to **Propeller Replacement**.
3. Place the drain pan below the outboard.
4. Remove the vent plug and the fill/drain plug.

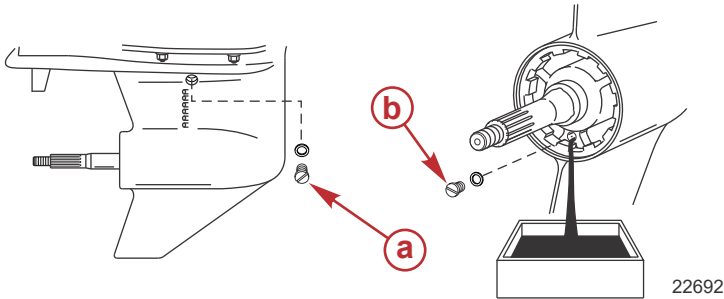

- a** - Vent plug
- b** - Fill/drain plug

5. Allow the lubricant to completely drain from the gearcase.

Gearcase Lubricant Capacity

Gearcase Lubricant Capacity (approximate)	
Right-hand rotation	830 ml (28.1 fl oz)
Left-hand rotation	

Gearcase Lubricant Recommendation

Mercury or Quicksilver High Performance Gear Lubricant.

Checking Lubricant Level and Refilling Gearcase

1. Place the outboard in a vertical operating position.
2. Remove the vent plug/sealing washer.

MAINTENANCE

3. Remove the fill/drain plug. Place the lubricant tube into the fill hole and add the lubricant until it appears at the vent hole.

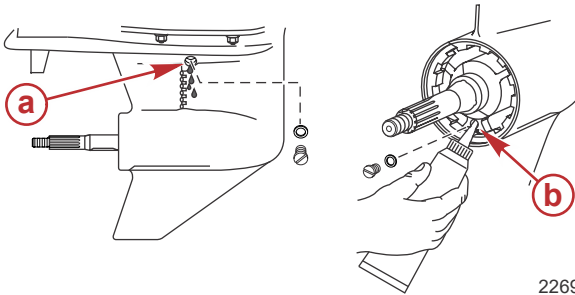

a - Vent hole

b - Fill hole

IMPORTANT: Replace the sealing washers if damaged.

4. Stop adding the lubricant. Install the vent plug and sealing washer before removing the lubricant tube.
5. Remove the lubricant tube and install cleaned fill/drain plug and sealing washer.

Lubrication Points

⚠ WARNING

Incorrect cable lubrication can cause hydraulic lock, leading to serious injury or death from loss of boat control. Completely retract the end of the steering cable before applying lubricant.

1. Lubricate the propeller shaft with Extreme Grease.

Description	Where Used	Part No.
Extreme Grease	Propeller shaft	8M0190472

- Refer to **Propeller Replacement** for removal and installation of the propeller.

MAINTENANCE

- Coat the entire propeller shaft with lubricant to prevent the propeller hub from corroding and seizing to the shaft.

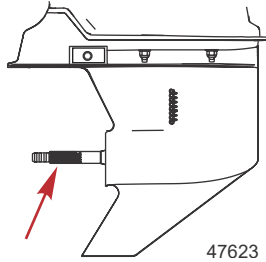

2. Lubricate the steering cable grease fitting (if equipped) with Extreme Grease.

- Rotate the steering wheel to fully retract the steering cable end into the outboard tilt tube.
- Lubricate through the fitting.

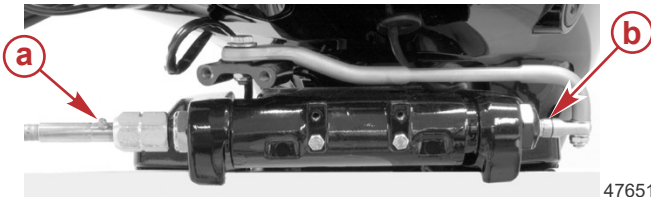

- a** - Fitting
- b** - Steering cable end

3. Lubricate the steering link rod pivot points with lightweight oil.

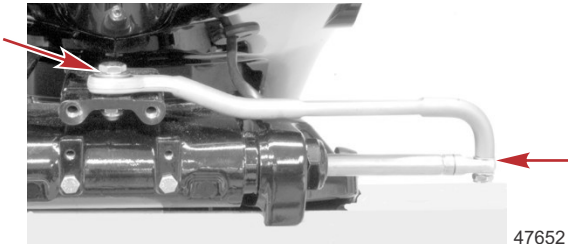

MAINTENANCE

Checking Power Trim Fluid

1. Tilt the outboard to the full up position, and engage the tilt support lever.

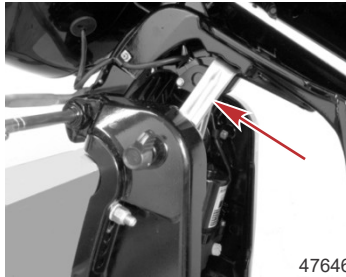

2. Remove the fill cap and check the fluid level. The fluid level should be even with the bottom of the fill hole.



3. Add Quicksilver or Mercury Precision Lubricants Power Trim and Steering Fluid, as required. If not available, use automotive automatic transmission fluid (ATF).

Description	Where Used	Part No.
Power Trim and Steering Fluid	Power trim reservoir	92-858074K01

Propeller Replacement

⚠ WARNING

Rotating propellers can cause serious injury or death. Never operate the boat out of the water with a propeller installed. Before installing or removing a propeller, place the drive unit in neutral and activate the lanyard stop switch to prevent the engine from starting. Place a block of wood between the propeller blade and the anti-ventilation plate.

MAINTENANCE

1. Shift the outboard to the neutral (N) position.



2. Straighten the bent tabs on the propeller nut retainer.
3. Place a block of wood between the gearcase and the propeller to hold the propeller, and remove the propeller nut.

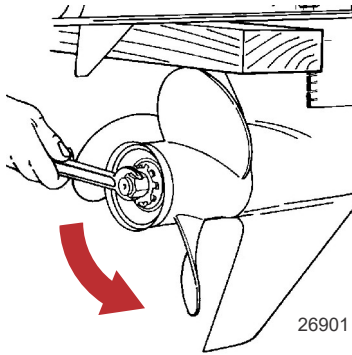

4. Pull the propeller straight off the shaft. If the propeller is seized to the shaft and cannot be removed, have the propeller removed by a Mercury Marine authorized dealer.

IMPORTANT: To prevent the propeller hub from corroding and seizing to the propeller shaft, especially in saltwater, always apply a coat of the recommended lubricant to the entire propeller shaft at the recommended maintenance intervals and also each time the propeller is removed.

5. Coat the propeller shaft with Extreme Grease.

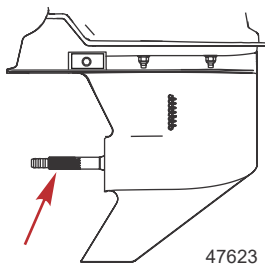

MAINTENANCE

Description	Where Used	Part No.
Extreme Grease	Propeller shaft	8M0190472

Flo-Torq II Propellers

1. Install the propeller onto the shaft with the supplied components as shown.
2. Place the locknut retainer over the raised pins on the drive sleeve adapter, and tighten the locknut to the specified torque.
3. Secure the locknut by bending the tabs up against the locknuts.

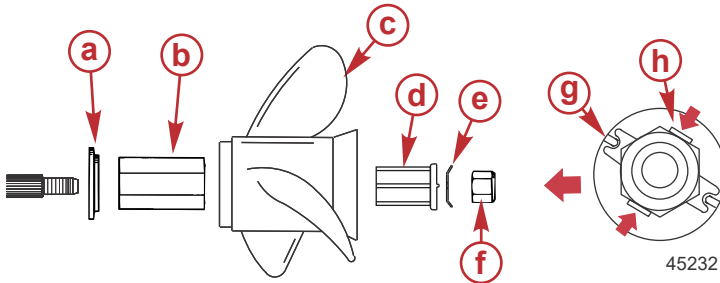

- a** - Forward thrust washer
- b** - Drive sleeve
- c** - Propeller
- d** - Drive sleeve adapter
- e** - Locknut retainer
- f** - Locknut
- g** - Raised pins
- h** - Tabs bent against the locknut

Description	Nm	lb-in.	lb-ft
Propeller nut	75	-	55.3

Flo-Torq IV Propellers

1. Install the propeller onto the shaft with the supplied components as shown.
2. Tighten the locknut to the specified torque.

MAINTENANCE

3. Secure the locknut by bending three of the tabs into the grooves in the drive sleeve adapter.

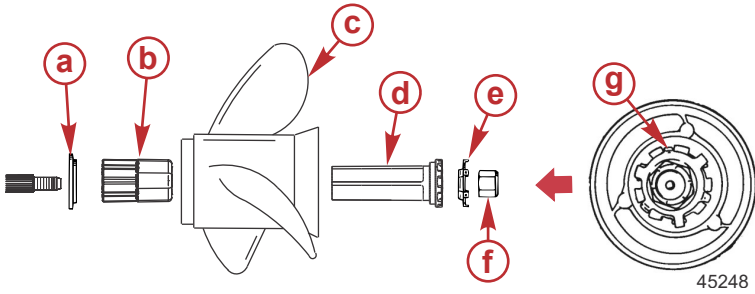

- a** - Forward thrust washer
- b** - Drive sleeve
- c** - Propeller
- d** - Drive sleeve adapter
- e** - Locknut retainer
- f** - Locknut
- g** - Tabs bent into grooves

Description	Nm	lb-in.	lb-ft
Propeller nut	75	–	55.3

Propeller Bore Sleeve Inspection—If Equipped

IMPORTANT: An authorized dealer should replace the propeller bore sleeve if it is suspected of being worn, if it is loose, or if the retention tabs are broken.

MAINTENANCE

The propeller bore sleeve is an important integral component of the gear housing and should be inspected whenever the propeller is removed. The propeller bore sleeve is designed to enhance engine characteristics and boat performance by minimizing engine exhaust escaping between the outside of the propeller and the gear housing. Exhaust gas mixing with the water over the propeller blades will cause a loss of engine and boat performance.

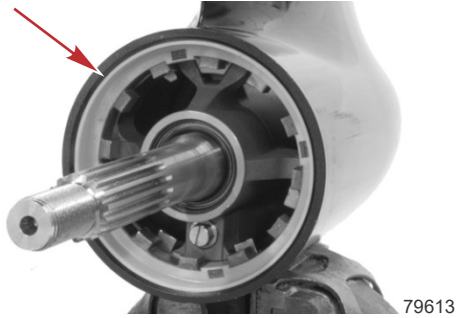

Propeller bore sleeve

Spark Plug Inspection and Replacement

1. Remove the spark plug leads. Pull the rubber boots off the spark plugs.

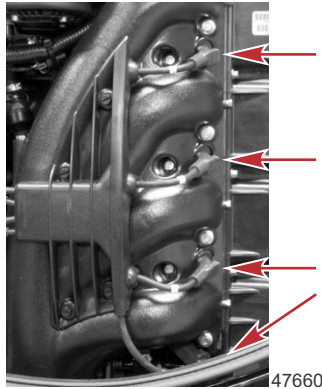

MAINTENANCE

2. Remove the spark plugs to inspect.

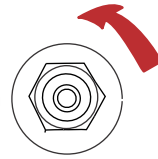
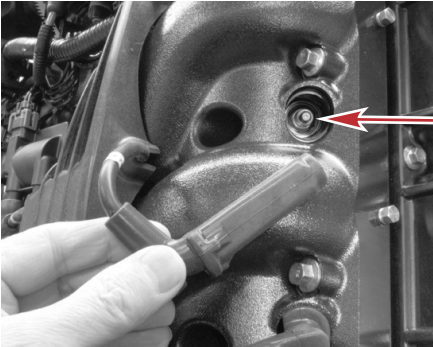

47662

3. Replace the spark plug if the electrode is worn; the insulator is rough, cracked, broken, or blistered; or if the precious metal is not visible on the spark plug electrode.

IMPORTANT: The color of the plug may not accurately reflect its condition. To accurately diagnose a faulty plug, inspect the precious metal on the plug's electrode. If no precious metal is visible, replace the plug.

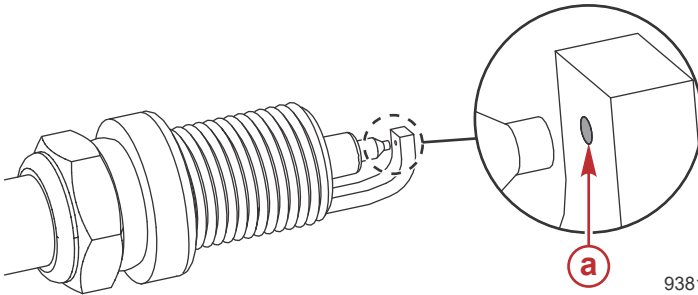

9381

a - Precious metal

4. Set the spark plug gap. Refer to **Specifications**.

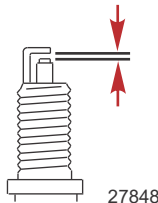

27848

- a. All of the spark plugs should have the gap checked and corrected as necessary before installation.

MAINTENANCE

- b. Measure the gap with a feeler gauge or pin gauge. Never use a wedge-type gap checking tool to inspect or to adjust the gap.
 - c. If an adjustment is necessary, do not pry or apply any force on the center electrode. This is critical with any type of spark plug that has a wear surface, such as platinum or iridium added to either the ground electrode or the center electrode.
 - d. When it is necessary to widen the gap, use a tool that only pulls back on the ground electrode without touching the center electrode, the porcelain, or the wear portion of the ground electrode.
 - e. When it is necessary to close the gap, gently tap the plug ground electrode on a hard surface.
5. Saltwater use - Apply a thin coating of Anti-Seize Compound only on threads of spark plugs.

Description	Where Used	Part No.
Anti-Seize Compound	Spark plug threads	92-898101389

6. Before installing spark plugs, clean off any dirt on the spark plug seats. Install the plugs finger-tight and then tighten an additional 1/4 turn or tighten to the specified torque.

Description	Nm	lb-in.	lb-ft
Spark plug	27	–	20

Transom Tightness Inspection

Inspect the outboard for tightness to the boat transom. If any looseness of the outboard or mounting fasteners exist, tighten the outboard mounting fasteners to the specified torque.

Description	Nm	lb-in.	lb-ft
Outboard mounting locknuts and bolts - standard boat transom	75	–	55.3
Outboard mounting locknuts and bolts - metal lift plates and setback brackets	122	–	90

When looking for signs of looseness, look for loss of outboard transom bracket material or paint caused by movement between the outboard mounting fasteners and the outboard transom brackets. Also look for signs of movement between the outboard transom brackets and the boat transom (lift plate/setback bracket).

MAINTENANCE

Notes:

STORAGE

Storage Preparation

The major consideration in preparing an outboard for storage is to protect it from rust, corrosion, and damage caused by the freezing of trapped water.

The following storage procedures should be used to prepare an outboard for out of season storage or prolonged storage (90 days or longer).

Protecting the Fuel System

NOTICE

Without sufficient cooling water, the engine, the water pump, and other components will overheat and suffer damage. Provide a sufficient supply of water to the water inlets during operation.

IMPORTANT: Gasoline containing alcohol (ethanol or methanol) can cause a formation of acid during storage and can damage the fuel system. If the gasoline being used contains alcohol, drain as much of the remaining gasoline as possible from the fuel tank, remote fuel line, and engine fuel system.

Fill the fuel tank and engine fuel system with treated (stabilized) fuel to help prevent formation of varnish and gum. Proceed with the following instructions.

- Portable fuel tank - Pour the required amount of Quickstor Fuel Stabilizer (follow instructions on container) into the fuel tank. Tip the fuel tank back and forth to mix the stabilizer with the fuel.
- Permanently installed fuel tank - Pour the required amount of Quickstor Fuel Stabilizer (follow instructions on container) into a separate container and mix it with approximately 1 liter (1 U.S. quart) of gasoline. Pour this mixture into fuel tank.

Description	Where Used	Part No.
Quickstor Fuel Stabilizer	Fuel tank	92-8M0047932

- Place the outboard in water or connect a flushing attachment for circulating cooling water. Run the engine for ten minutes to fill the engine fuel system.

Flushing Device	91-44357Q 2
	Attaches to the water intakes; provides a fresh water connection when flushing the cooling system or operating the engine.

Protecting External Outboard Components

- Lubricate all outboard components listed in **Maintenance - Inspection and Maintenance Schedule**.

STORAGE

- Touch up any paint nicks. See an authorized dealer for touch-up paint.
- Spray Quicksilver or Mercury Precision Lubricants Corrosion Guard on external metal surfaces (except corrosion control anodes).

Description	Where Used	Part No.
Corrosion Guard	External metal surfaces	92-802878 55

Protecting Internal Engine Components

IMPORTANT: Refer to Maintenance - Spark Plug Inspection and Replacement for correct procedure for removing spark plugs.

- Change the engine oil and filter.
- Remove the spark plugs.
- Spray approximately 30 ml (1 fl oz) of Storage Seal Rust Inhibitor into each spark plug hole.

Description	Where Used	Part No.
Storage Seal Rust Inhibitor	Spark plug holes	92-858081K03

- Actuate key/push button start switch to crank the engine through one start cycle, which will distribute the storage seal throughout the cylinders.
- Install the spark plugs.

Gearcase

- Drain and refill the gearcase lubricant (refer to **Gearcase Lubricant**).

Positioning Outboard for Storage

NOTICE

Storing the outboard in a tilted position can damage the outboard. Water trapped in the cooling passages or rain water collected in the propeller exhaust outlet in the gearcase can freeze. Store the outboard in the full down position.

Store the outboard in an upright (vertical) position to allow water to drain out of the outboard.

Battery Storage

- Follow the battery manufacturer's instructions for storage and charging.
- Remove the battery from the boat and check the charge. Charge if necessary.
- Store the battery in a cool, dry place.

STORAGE

- Periodically check the battery voltage during storage. Charge if necessary.

STORAGE

Notes:

TROUBLESHOOTING

Effects of Elevation and Weather on Performance

Power Robbing Conditions

The following conditions lower engine performance and cannot be compensated by the engine fuel or electronic management systems:

- High elevations
- High ambient temperature
- Low barometric pressure
- High humidity

These conditions reduce the air density to the engine, which in turn lowers the following:

- Boost pressure on supercharged engines
- Horsepower and torque throughout the RPM range
- Peak RPM
- Cranking compression

EXAMPLES: An engine running at an elevation of 2,438 m (8,000 ft) will have over a 30% power loss. A loss of engine power on a hot and humid day could be as much as 14%. These losses apply to normally aspirated and supercharged engines.

Compensating for Power Robbing Conditions

Some boat performance can be improved by dropping to a lower pitch propeller, but engine performance will still remain lower. To optimize engine performance, prop the engine to allow it to operate at or near the top end of the recommended maximum RPM range at wide-open throttle with a normal boat load.

In some cases, a gear ratio reduction may be more beneficial.

Fuse Replacement

IMPORTANT: Always carry spare fuses.

The electrical wiring circuits on the outboard are protected from overload by fuses in the wiring. If a fuse is blown, try to locate and correct the cause of the overload. If the cause is not found, the fuse may blow again.

TROUBLESHOOTING

Open the fuse holder and look at the silver colored band inside the fuse. If the band is broken, replace the fuse. Replace fuse with a new fuse with the same rating.

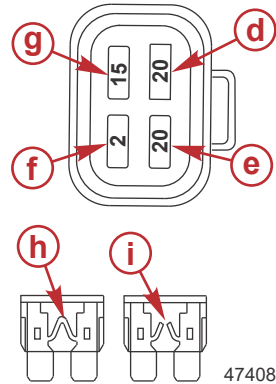
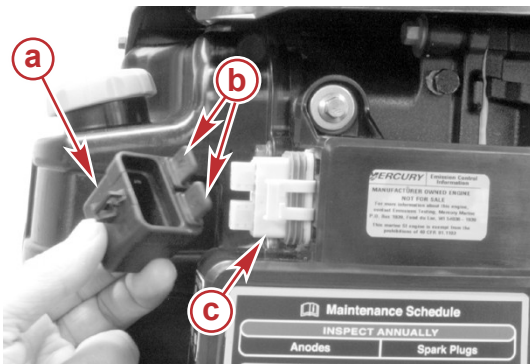

- a** - Cover
- b** - Spare fuse holders
- c** - Fuse holder
- d** - Fuse 4 - IGN. 20 amp - ignition system
- e** - Fuse 2 - FUEL 20 amp - fuel delivery
- f** - Fuse 1 - DIAG. 2 amp - diagnostics/vessel (accessory) harness
- g** - Fuse 3 - HELM 15 amp - 14 pin remote control harness/cowl trim switch
- h** - Good fuse
- i** - Blown fuse

Starter Motor Will Not Crank the Engine

Possible causes

- Lanyard stop switch not in **RUN** position.
- Blown 15-amp fuse. Check the 14-pin remote control harness/cowl trim switch fuse. Refer to **Fuse Replacement**.
- Outboard is not shifted to neutral position.
- Weak battery or battery connections are loose or corroded.
- Ignition key switch failure.
- Wiring or electrical connection faulty.
- Starter motor solenoid or slave solenoid failure.

Engine Will Not Start

Possible causes

- Incorrect starting procedure. Refer to **Operation** section.
- Old or contaminated gasoline.

TROUBLESHOOTING

- Fuel is not reaching the engine.
 - Fuel tank is empty.
 - Fuel tank vent not open or restricted.
 - Fuel line is disconnected or kinked.
 - Fuel filter is obstructed. Refer to **Maintenance** section.
 - Fuel pump failure.
 - Fuel tank filter obstructed.
- Ignition system component failure.
- Spark plugs fouled or defective. Refer to **Maintenance** section.

Engine Runs Erratically

Possible Causes

- Overheating - Warning horn not working.
- Low oil pressure. Check oil level.
- Spark plugs fouled or defective. Refer to **Maintenance** section.
- Incorrect setup and adjustments.
- Fuel is being restricted to the engine.
 - a. Engine fuel filter is obstructed. Refer to **Maintenance** section.
 - b. Fuel tank filter obstructed.
 - c. Stuck anti-siphon valve located on permanently built-in type fuel tanks.
 - d. Fuel line is kinked or pinched.
- Fuel pump failure.
- Ignition system component failure.

Performance Loss

Possible causes

- Overheating - Warning horn not working.
- Low oil pressure. Check oil level.
- Throttle not opening fully.
- Damaged propeller or improper propeller size.
- Incorrect engine timing, adjustment, or setup.
- Boat overloaded or load improperly distributed.
- Excessive water in bilge.
- Boat bottom is dirty or damaged.

TROUBLESHOOTING

Battery Will Not Hold Charge

Possible Causes

- Battery connections are loose or corroded.
- Worn out or inefficient battery.
- Excessive use of electrical accessories.
- Defective rectifier, alternator, or voltage regulator.
- Open circuit in the alternator output wire (fused link).

Submerged Outboard

A submerged outboard will require service within a few hours by an authorized dealer once the outboard is recovered from the water. This immediate attention by a servicing dealer is necessary once the engine is exposed to the atmosphere to minimize internal corrosion damage to the engine.

OWNER SERVICE ASSISTANCE

Identification Records

The serial numbers are the manufacturer's keys to numerous engineering details that apply to a specific Mercury Marine power package. When contacting Mercury Marine about service, **always specify model and serial numbers.**

Please record the following applicable information:

Outboard		
Engine Model and Horsepower		
Engine Serial Number		
Gear Ratio		
Propeller Number	Pitch	Diameter
Watercraft Identification Number (WIN) or Hull Identification Number (HIN)		Purchase Date
Boat Manufacturer	Boat Model	Length
Exhaust Gas Emissions Certification Number (Europe Only)		

Service Assistance

Local Repair Service

If your Mercury-outboard-powered boat needs service, take it to a Mercury Marine Authorized Dealer. Only authorized dealers specialize in Mercury products and have factory-trained mechanics, special tools and equipment, and genuine Quicksilver parts and accessories to properly service your engine.

NOTE: *Quicksilver parts and accessories are engineered and built by Mercury Marine specifically for your power package.*

Service Away From Home

If you are away from your local dealer and the need for service arises, contact the nearest authorized dealer. If, for any reason, you cannot obtain service, contact the nearest Regional Service Center. Outside the United States and Canada, contact the nearest Marine Power International Service Center.

Stolen Power Package

If your power package is stolen, immediately advise the local authorities and Mercury Marine of the model and serial numbers and to whom the recovery is to be reported. This information is maintained in a database at Mercury Marine to aid authorities and dealers in the recovery of stolen power packages.

OWNER SERVICE ASSISTANCE

Attention Required After Submersion

1. Before recovery, contact a Mercury Marine Authorized Dealer.
2. After recovery, immediate service by a Mercury Marine Authorized Dealer is required to reduce the possibility of serious engine damage.

Replacement Service Parts

⚠ WARNING

Avoid fire or explosion hazard. Electrical, ignition, and fuel system components on Mercury Marine products comply with federal and international standards to minimize risk of fire or explosion. Do not use replacement electrical or fuel system components that do not comply with these standards. When servicing the electrical and fuel systems, properly install and tighten all components.

Marine engines are expected to operate at or near full throttle for most of their lives. They are also expected to operate in both fresh and saltwater environments. These conditions require numerous special parts.

Parts and Accessories Inquiries

Direct any inquiries concerning genuine Mercury Precision Parts® or Quicksilver Marine Parts and Accessories® to a local authorized dealer. Dealers have the proper systems to order parts and accessories, if they are not in stock. **Engine model** and **serial number** are required to order correct parts.

Resolving a Problem

Satisfaction with your Mercury Marine product is important to your dealer and to us. If you ever have a problem, question or concern about your power package, contact your dealer or any Mercury Marine Authorized Dealer. If you need additional assistance:

1. Talk with the dealership's sales manager or service manager.
2. If your question, concern, or problem cannot be resolved by your dealership, please contact the Mercury Marine Service Office for assistance. Mercury Marine will work with you and your dealership to resolve all problems.

The following information will be needed by the Customer Service:

- Your name and address
- Your daytime telephone number
- The model and serial numbers of your power package
- The name and address of your dealership
- The nature of the problem

Contact Information for Mercury Marine Customer Service

For assistance, call, fax, or write to the geographic office in your area. Please include your daytime telephone number with mail and fax correspondence.

OWNER SERVICE ASSISTANCE

United States, Canada		
Telephone	English +1 920 929 5040 Français +1 905 636 4751	Mercury Marine W6250 Pioneer Road P.O. Box 1939 Fond du Lac, WI 54936-1939
Fax	English +1 920 929 5893 Français +1 905 636 1704	
Website	www.mercurymarine.com	

Australia, Pacific		
Telephone	+61 3 9791 5822	Brunswick Asia Pacific Group 41-71 Bessemer Drive Dandenong South, Victoria 3175 Australia
Fax	+61 3 9706 7228	

Europe, Middle East, Africa		
Telephone	+32 87 32 32 11	Brunswick Marine in EMEA, LLC Avenue Mercury 8 B-4800 Verviers, Belgium
Email	BME.service@mercmarine.com	

Mexico, Central America, South America, Caribbean		
Telephone	+1 954 744 3500	Mercury Marine 11650 Interchange Circle North Miramar, FL 33025 U.S.A.
Fax	+1 954 744 3535	

Asia, Singapore, Japan		
Telephone	+65 68058100	Mercury Marine Singapore Pte Ltd 11 Changi South Street 3, #01-02 Singapore, 486122
Fax	+65 68058138	

Ordering Literature

Before ordering literature, have the following information about your power package available:

Model		Serial Number	
Horsepower		Year	

United States and Canada

For additional literature for your Mercury Marine power package, contact your nearest Mercury Marine dealer or contact:

OWNER SERVICE ASSISTANCE

Mercury Marine		
Telephone	Fax	Mail
(920) 929-5110	(920) 929-4894	Mercury Marine Attn: Publications Department P.O. Box 1939 Fond du Lac, WI 54936-1939

Outside the United States and Canada

Contact your nearest Mercury Marine authorized service center to order additional literature that is available for your particular power package.

Submit the following order form with payment to:	Mercury Marine Attn: Publications Department W6250 Pioneer Road P.O. Box 1939 Fond du Lac, WI 54936-1939
--	--

Ship To: (Copy this form and print or type—This is your shipping label)

Name	
Address	
City, State, Province	
ZIP or postal code	
Country	

Quantity	Item	Stock Number	Price	Total
			.	.
			.	.
			.	.
			.	.
			.	.
Total Due				.

