

# CLASSIC 380 LS

# SPECIFICATIONS

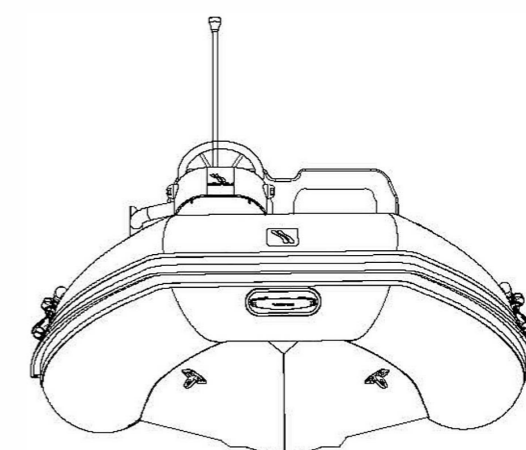
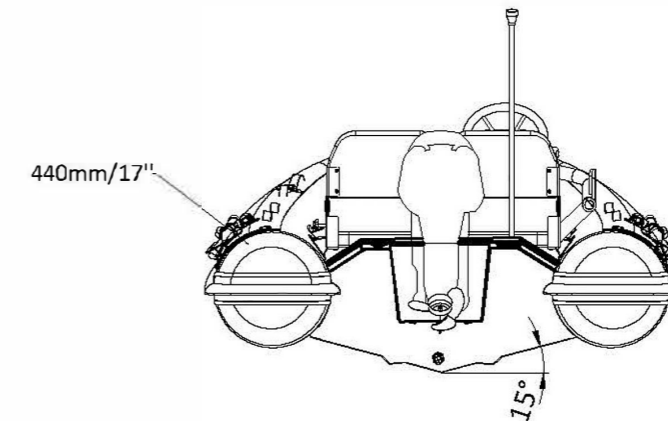
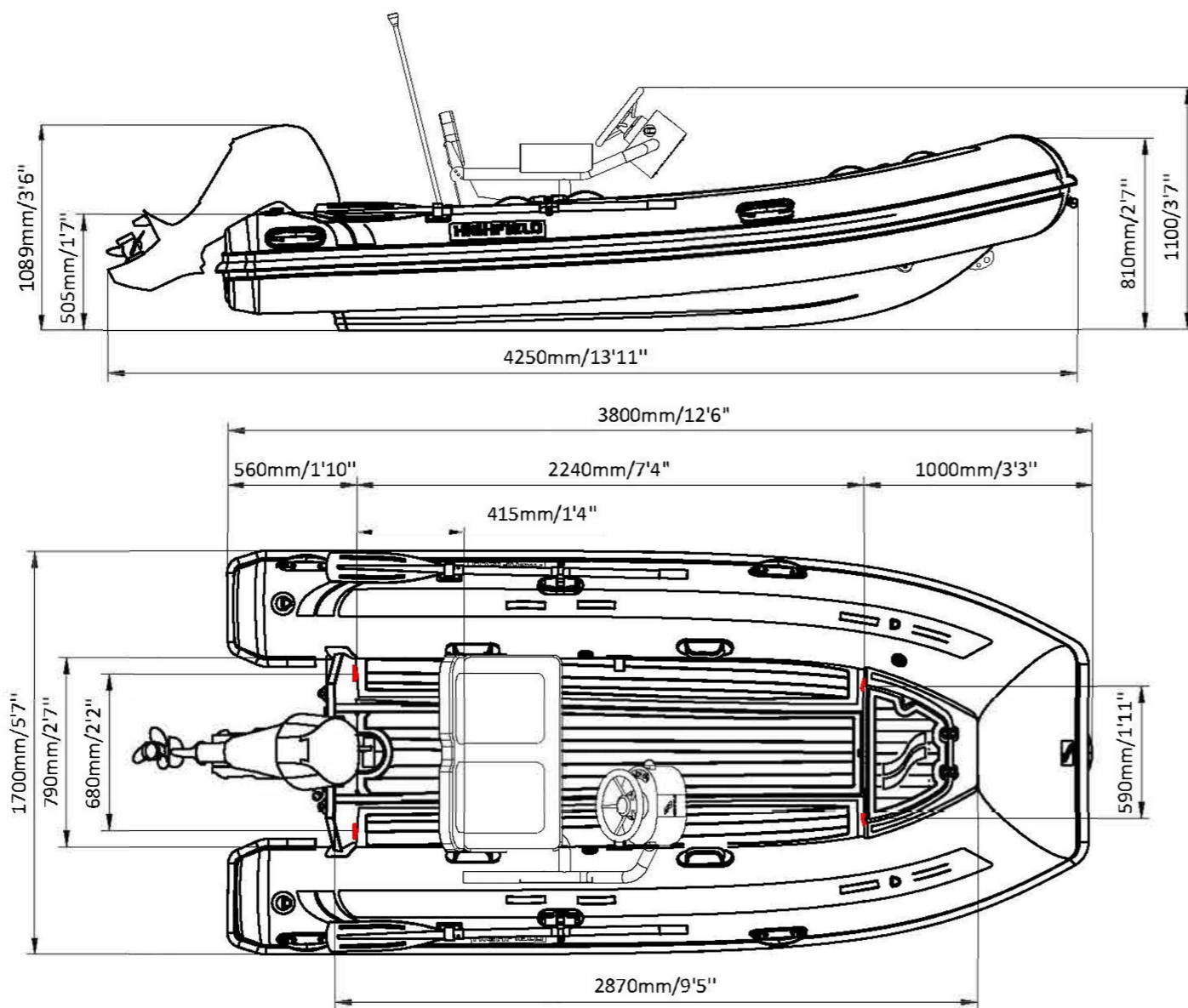

SPECIFICATIONS AND MAXIMUM CAPACITIES (Subject to change without notice. Tolerances: dimensions ±2.5%, weights ±5%)

MODEL	ISO 6185 PART	ISO 6185			#			Shaft	Outboard Engine				FCT		Molded seat		Oars		Fuel tank Capacity		Wet Weight (Approximate) with 25hp Yamaha (+35lbs w 30hpTohatsu)		AIR CHAMBERS				
			KG	LB		KG	LB		Max power		Max weight		KG	LB	KG	LB	KG	LB	L	GAL	KG	LB		PSI	BAR		
									KW	HP	KG	LB															
CL380LS	3	C	637	1404	7	525	1157	S	22.38	30	124.1	274	85	187	36	79	3	6.6	1.5	3.3	/	/	216	476	3	3.63	0.25

Weight: boat only.