

# Defender FR430 PVC

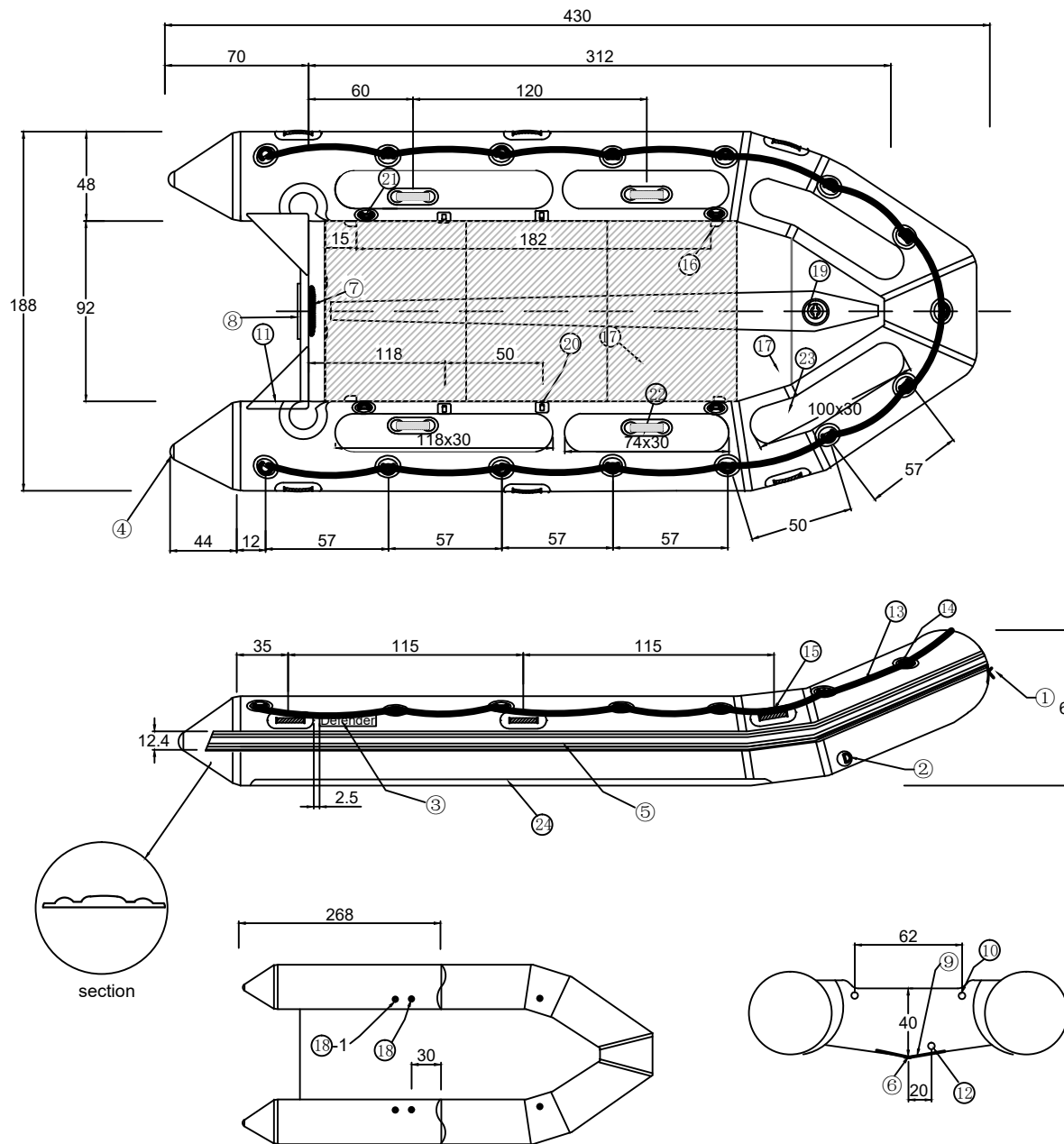

## NOTES:

ALL DIMENSIONS IN cm

## Item # Description

- 1 Bow Handle(Stainless steel) x 1ea
- 2 Towing bridle D-Ring x 2ea
- 3 Side Logo x 2ea
- 4 Cone end cap x 2ea
- 5 Rubbing strake
- 6 Rubbing strake on keel x 1ea
- 7 Plastic Transom Pad x 1ea
- 8 Plastic Transom Plate x 1ea
- 9 Transom Bottom ptoction x 1ea
- 10 Transom Tow Eyes,SS x 2ea
- 11 Splash Guard x 2ea
- 12 Drain Plug assembly x 1ea
- 13 Exterior Life line x 1ea
- 14 L-D-Ring,for exterior life lines x 15ea
- 15 Lifting Handles x 6ea
- 16 Stringer Retainer x 4ea
- 17 Aluminum floor ,w/Fabric Coated floor x 5ea
- 18 Valve,Tube inflation x 3ea
- 18-1 OP. Valve, x 3ea
- 19 Valve,Keel inflation x 1ea
- 20 Paddle Retainer x 4ea
- 21 M-D-Ring For Lifting Points x 4ea
- 22 Seat Webbing x 4ea
- 23 Anti chaffing guard x 6ea
- 24 Reinforcing R/Strake x 2ea

All dimension measurements indicated have a tolerance of  $\pm 2.5\%$

**Defender**<sup>®</sup>  
Marine Outfitters of Choice Since 1938