

MaxiBus - 250A Common BusBars

Insert-molded stainless steel studs and optional fully enclosed insulating base and cover

- Insulating cover with breakouts for easy wire access
- Insulating cover meets ABYC insulation requirements
- One-piece serrated flange nuts ensure correct and secure connections

Continuous Rating	250A AC / 250A DC
Voltage Max. Operating	300V AC / 48V DC
Mounting Hardware	#10 (M5) Screws
Bus Material	Tin-Plated Copper C11000
Regulatory	CE & UKCA certified



2128



2105



2127



2126

Part #	Terminal Studs	Terminal Screws	[A] Length in (mm)	[B] Mounting Centers in (mm)
2105	2 × 5/16" -18	12 × #10-24	7.75 (197.00)	7.125 (181.00)
2126	6 × 5/16" -18	-	7.75 (197.00)	7.125 (181.00)
2718	Cover for 2105 and 2126	-	8.78 (223.10)	5.41 (137.30)
2127	4 × 5/16" -18	-	5.875 (149.00)	5.25 (133.00)
2128	2 × 5/16" -18	6 × #10-24	5.875 (149.00)	5.25 (133.00)
2719	Cover for 2127 and 2128	-	6.70 (170.00)	4.10 (104.10)

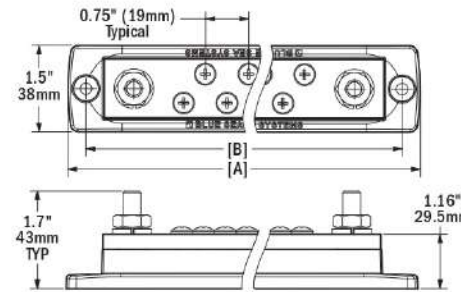

2128, 2105

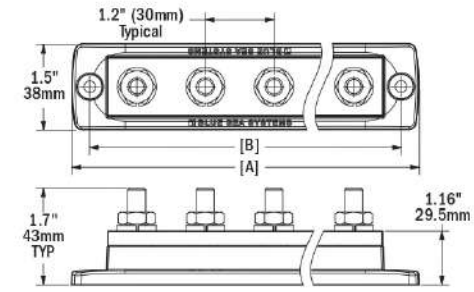

2127, 2126

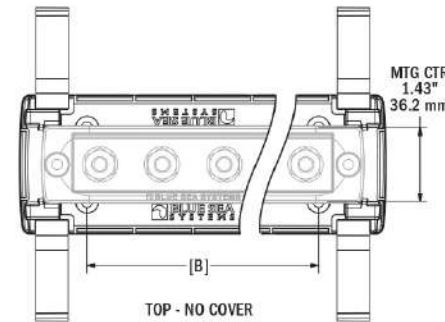

2719 and 2718

