



## BALMAR CENTERFIELDER-II Installation & Operator's Manual

### INTRODUCTION

Designed for use in applications requiring balanced charge control from two alternators and two regulators on twin engines, the Centerfielder-II makes it possible to utilize the combined output of both alternators to supply optimized charging to a single large battery bank.

By monitoring the ignition and field voltages at port and starboard regulators, the Centerfielder-II determines when both engines are running, and directs field current from the most dominant regulator to both alternators. By controlling both alternators with the same field source, the Centerfielder ensures that alternators can work together, rather than in conflict, when charging the same batteries.

### INSTALLATION

The Centerfielder-II is easy to install. You will find, included with the Centerfielder-II, a collection of wiring terminal connectors as well as two fused 12-gauge RED wires required to replace the standard 14-gauge (RED) power wires in the Max Charge regulators' wiring harnesses.

DUE TO VARIATIONS IN WIRE SIZE AND LENGTH BASED ON APPLICATIONS, FIELD, IGNITION, AND DASH LAMP WIRES ARE USER SUPPLIED. See the chart in these instructions to determine proper wire gauge, based on length of wire run.

To install:

1. Disconnect batteries or turn battery switches to the OFF position.
2. Install the Centerfielder-II on a bulkhead or other flat surface that's away from extreme heat or moisture. Typically, the Centerfielder is mounted close to one, or the other, voltage regulator.
3. Determine the distances and gauges required for wire runs between the Centerfielder-II, the Max Charge regulators and the port and starboard alternators.
4. Connect the supplied wiring connectors to their appropriate wires, as described to the right, and connect to the Centerfielder, regulators and alternators as shown.
5. Remove the existing RED power wires from the Max Charge wiring harnesses and replace with the included, fused RED 12-gauge wires.
6. Re-connect batteries and start engines. Indicator LEDs will light as the Centerfielder-II controls field output from the regulators to the two alternators.

## BALMAR CENTERFIELDER II Terminal and Lamp Layout

1. **PORT FIELD INPUT TERMINAL** - Connect to port voltage regulator's Field Output terminal via a user-supplied 12-gauge BLUE wire. A female 1/4" spade terminal is supplied with the Centerfielder-II for connection to Terminal #1. The 12-gauge BLUE wire will replace the regulator's 14-gauge field wire.
2. **PORT FIELD OUTPUT TERMINAL** - Connect the #2 port field output to the port alternator's field input terminal via a user supplied 12-gauge BLUE wire. A female 1/4" spade terminal is supplied with the Centerfielder-II for connection to Terminal #2. Alternator-side termination will vary based on alternator, and may require a user-supplied spade or ring terminal connector, depending on the alternator configuration.
3. **PORT "IGNITION ACTIVATED" LED (RED)** - Indicates activation of port voltage regulator's ignition wire. If LED is illuminated, but the port voltage regulator is inactive, check for voltage at the regulator's ignition terminal.
4. **PORT IGNITION OUTPUT** - Terminal #4 must be connected to the port side voltage regulator's BROWN ignition wire. A BROWN 14-Gauge user-supplied wire is recommended. A female 1/4" spade terminal is supplied with the Centerfielder.
5. **PORT IGNITION INPUT** - From port side engine ignition switch or port engine oil pressure switch. Terminal must see zero volts when the port engine is turned off, and battery voltage when the port engine is running. BROWN 14-Gauge user-supplied wire is recommended. A female 1/4" spade terminal is supplied with the Centerfielder-II.
6. **PORT DASH LAMP INPUT TERMINAL** - Connect the #6 port dash lamp terminal to the port voltage regulator's dash lamp terminal terminal via a user supplied 16-gauge wire. Female 1/4" spade terminals are supplied for connection to Terminal #6, and for connection to the regulator's dash lamp.
7. **PORT DASH LAMP OUTPUT TERMINAL** - Connect the #7 port dash lamp terminal to the port voltage regulator's dash lamp terminal terminal via a user supplied 16-gauge wire. Female 1/4" spade terminals are supplied for connection to Terminal #7, and for connection to the port regulator's dash lamp.
8. **PORT "DASH LAMP" LED (RED)** - Indicates activation of port voltage regulator's Dash Lamp terminal. Activation of the Dash Lamp may occur as a result of high or low voltage, high alternator or high battery temperature. If LED is illuminated, inspect the port voltage regulator long display for advisory codes.
9. **GROUND TERMINAL** - Connect the #9 ground terminal to system ground via 12-gauge BLACK wire. A female 1/4" spade terminal is supplied with the Centerfielder-II for connection to Terminal #9. Alternator-side termination will vary based on the ground source selected, and may require a user-supplied spade or ring terminal connector, depending on the ground location chosen. **ALL GROUND CONNECTIONS MUST BE COMMON.**
10. **STARBOARD "DASH LAMP" LED (GREEN)** - Indicates activation of starboard voltage regulator's Dash Lamp terminal. Activation of the Dash Lamp may occur as a result of high or low voltage, high alternator or high battery temperature. If LED is illuminated, inspect the port voltage regulator long display for advisory codes.
11. **STARBOARD DASH LAMP INPUT TERMINAL** - Connect the #11 port dash lamp terminal to the port voltage regulator's dash lamp terminal terminal via a user supplied 16-gauge wire. Female 1/4" spade terminals are supplied for connection to Terminal #11, and for connection to the regulator's dash lamp.
12. **STARBOARD DASH LAMP OUTPUT TERMINAL** - Connect the #12 starboard dash lamp terminal to the starboard voltage regulator's dash lamp terminal terminal via a user supplied 16-gauge wire. Female 1/4" spade terminals are supplied for connection to Terminal #12, and for connection to the starboard regulator's dash lamp.
13. **COMMUNICATIONS PORT** - Factory use only.
14. **COMMUNICATIONS PORT** - Factory use only.
15. **COMMUNICATIONS PORT** - Factory use only.

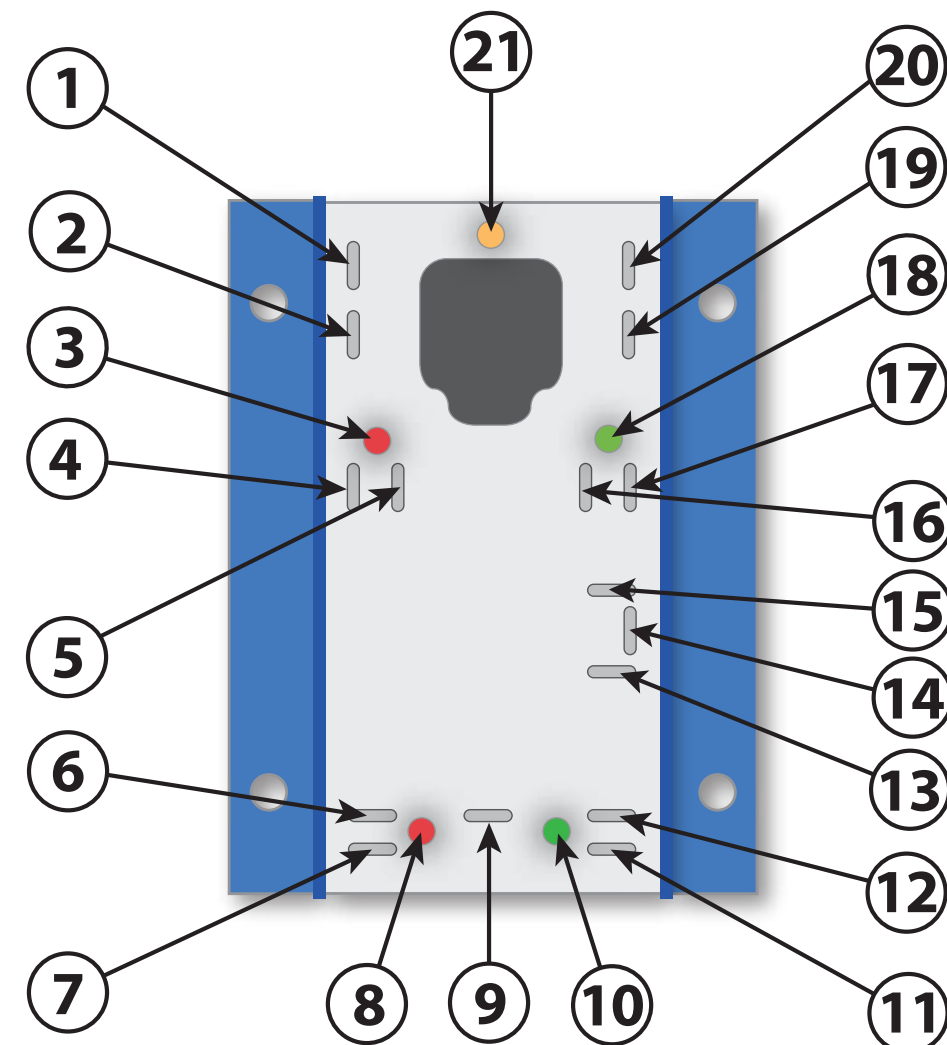

16. **STARBOARD IGNITION INPUT** - From starboard side engine ignition switch or starboard engine oil pressure switch. Terminal must see zero volts when the starboard engine is turned off, and battery voltage when the starboard engine is running. BROWN 14-Gauge user-supplied wire is recommended. A female 1/4" spade terminal is supplied with the Centerfielder-II for connection to Terminal #16.
17. **STARBOARD IGNITION OUTPUT** - Terminal #17 must be connected to the starboard side voltage regulator's BROWN ignition wire. A BROWN 14-Gauge user-supplied wire is recommended. A female 1/4" spade terminal is supplied with the Centerfielder-II for connection to Terminal #17.
18. **STARBOARD "IGNITION ACTIVATED" LED (GREEN)** - Indicates activation of starboard voltage regulator's ignition wire. If LED is illuminated, but the starboard voltage regulator is inactive, check for voltage at the regulator's ignition terminal.
19. **STARBOARD FIELD OUTPUT TERMINAL** - Connect the #19 starboard field output to the starboard alternator's field input terminal via a user supplied 12-gauge BLUE wire. A female 1/4" spade terminal is supplied with the Centerfielder-II for connection to Terminal #19. Alternator-side termination will vary based on alternator, and may require a user-supplied spade or ring terminal connector, depending on the alternator configuration.
20. **STARBOARD FIELD INPUT TERMINAL** - Connect to starboard voltage regulator's Field Output terminal via a user-supplied 12-gauge BLUE wire. A female 1/4" spade terminal is supplied with the Centerfielder-II for connection to Terminal #20. The 12-gauge BLUE wire will replace the regulator's 14-gauge field wire.
21. **"COMBINE" LED (AMBER)** - Indicates activation of port and starboard alternators and voltage regulators. The Centerfielder-II will continue to supply balanced field current to both port and starboard alternators when the LED is activated.

## BALMAR LIMITED PRODUCT WARRANTY

BALMAR warrants to the original consumer / purchaser the product is free from any defects in material or workmanship for a period of one year from the date of purchase. If any such defect is discovered within the warranty period, BALMAR will repair or replace the product free of charge, subject to verification of the defect or malfunction of the product by BALMAR Customer Service. BALMAR is not responsible for costs incurred for shipping to or from its headquarters.

This warranty DOES NOT apply to defects or physical damage resulting from abuse, neglect, accident, mis-application, unauthorized or improper installation or repair, alteration, modification, or unreasonable use of the products. Cracked or broken cases, or parts damaged by fire, water, freezing, collision, theft, explosion, rust, corrosion or items damaged in shipment in route to BALMAR for repair are not warrantable conditions. BALMAR assumes no responsibility for consequential damage, injury, loss or expense arising from use of these products or any labor required for service or repair. BALMAR holds no responsibility for costs incurred as a result of repairs initiated by facilities other than BALMAR's warranty repair department. It is up to the customer to ensure that any product returned to BALMAR is properly packed to provide ample protection against damage in shipment. Claims against shippers for damage in transit to or from BALMAR are the responsibility of the customer. BALMAR cannot be held liable for damage due to improper packaging and/or shipping processes.

BALMAR WILL NOT repair or be held responsible for any product returned to BALMAR without proper identification, return address and BALMAR issued Return Authorization (RA) number clearly marked on the package. Proof of date and place of purchase (photocopy of purchase invoice) must be included with products returned for warranty evaluation. Authorization for warranty evaluation and repair must be received from BALMAR Customer Service and issuance of an authorization number must occur prior to product return.

If factory service is required, contact our BALMAR Customer Service Department Monday through Thursday, 7:30 AM to 5:30 PM, or Friday, 7:30 AM to 1:00 PM (PST) at 360-435-6100.

Material required for the repair or replacement for the defective part or product is to be supplied free of charge upon delivery of the defective product to BALMAR, 18930 59th Ave. NE, Arlington, WA 98223. Customer is responsible for all return transportation charges and any air or rush delivery expense. BALMAR reserves the right to determine whether to repair or replace defective components. Returned warranty or non-warranty items deemed non-repairable will be disposed of after 30 days, unless claimed by owner. Balmar is not liable for damage to or loss of returned items.

THE ABOVE LIMITATIONS MAY NOT APPLY TO YOU. SOME STATES DO NOT ALLOW LIMITATIONS ON HOW LONG AN IMPLIED WARRANTY LASTS. NO PERSON, AGENT, DEALER IS AUTHORIZED TO GIVE ANY WARRANTY.

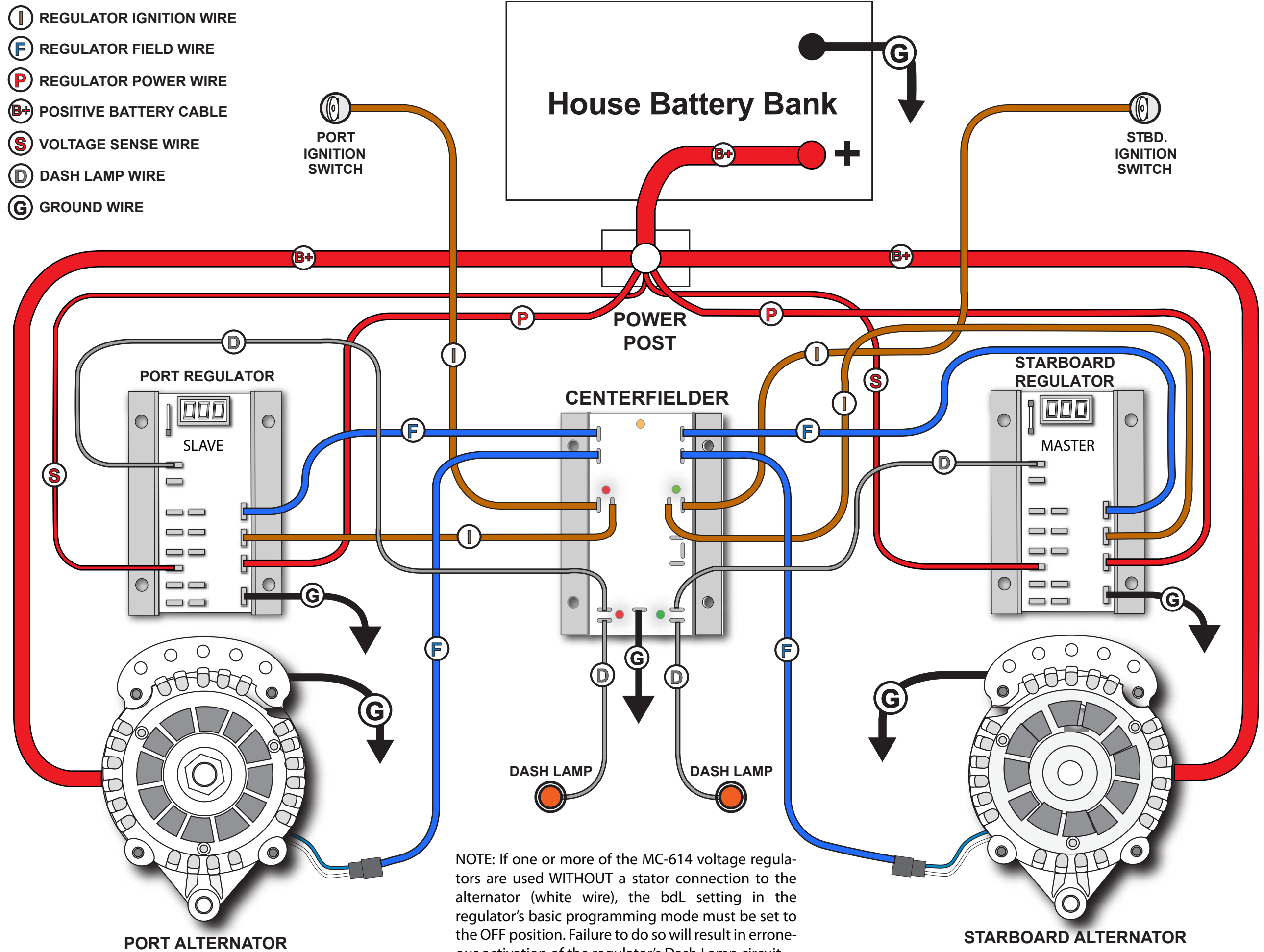

NOTE: If one or more of the MC-614 voltage regulators are used WITHOUT a stator connection to the alternator (white wire), the bdL setting in the regulator's basic programming mode must be set to the OFF position. Failure to do so will result in erroneous activation of the regulator's Dash Lamp circuit.