

PLANT VIEW  
VISTA SUPERIOR

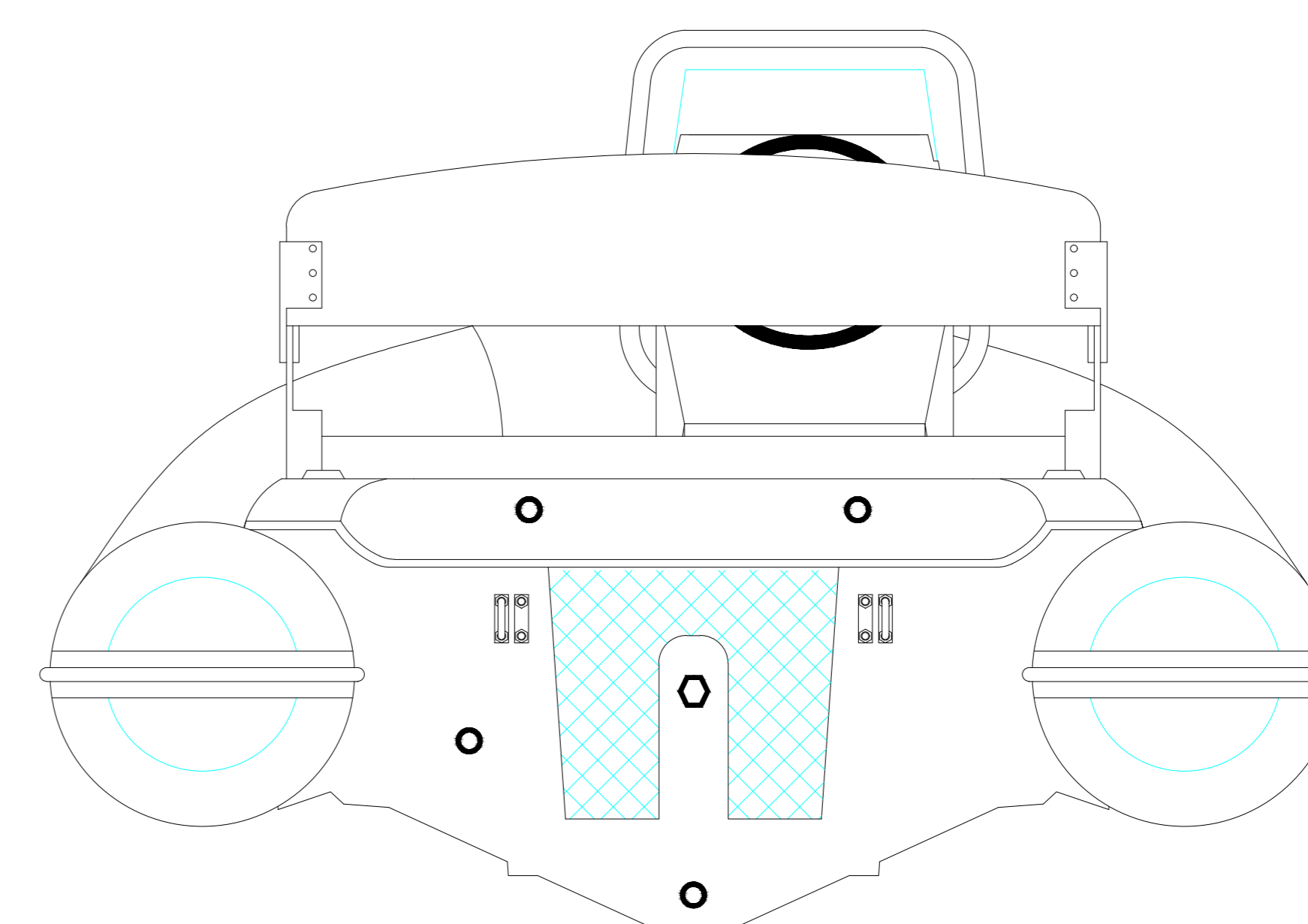

AFT VIEW  
VISTA TRASERA

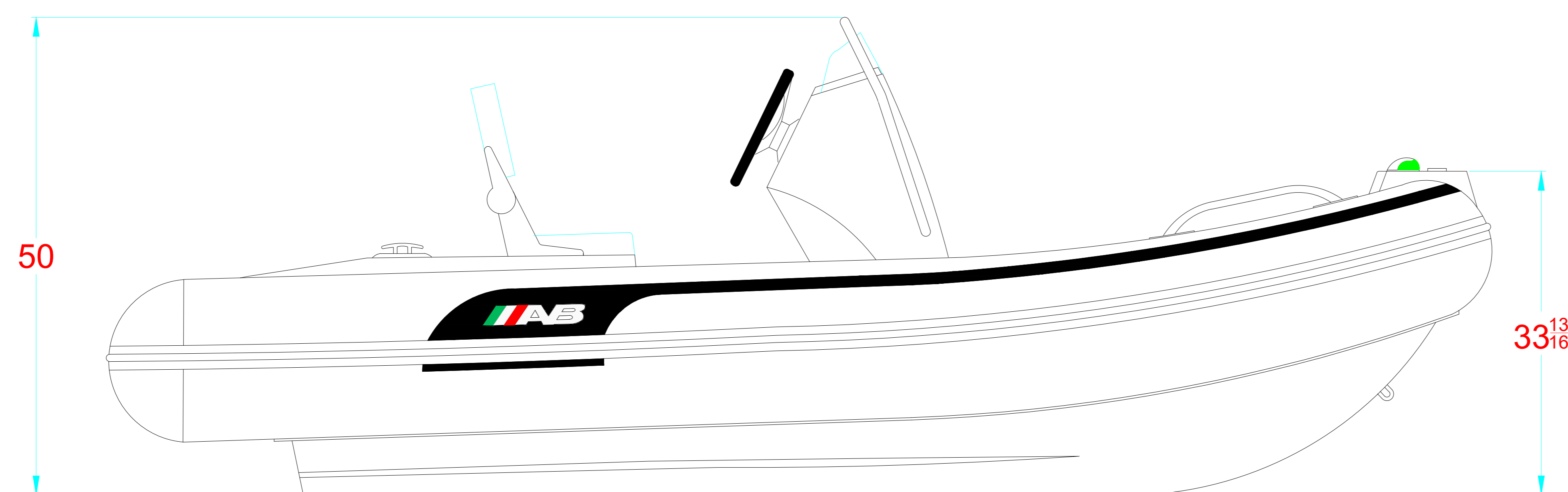

LONGITUDINAL PROFILE  
VISTA LATERAL

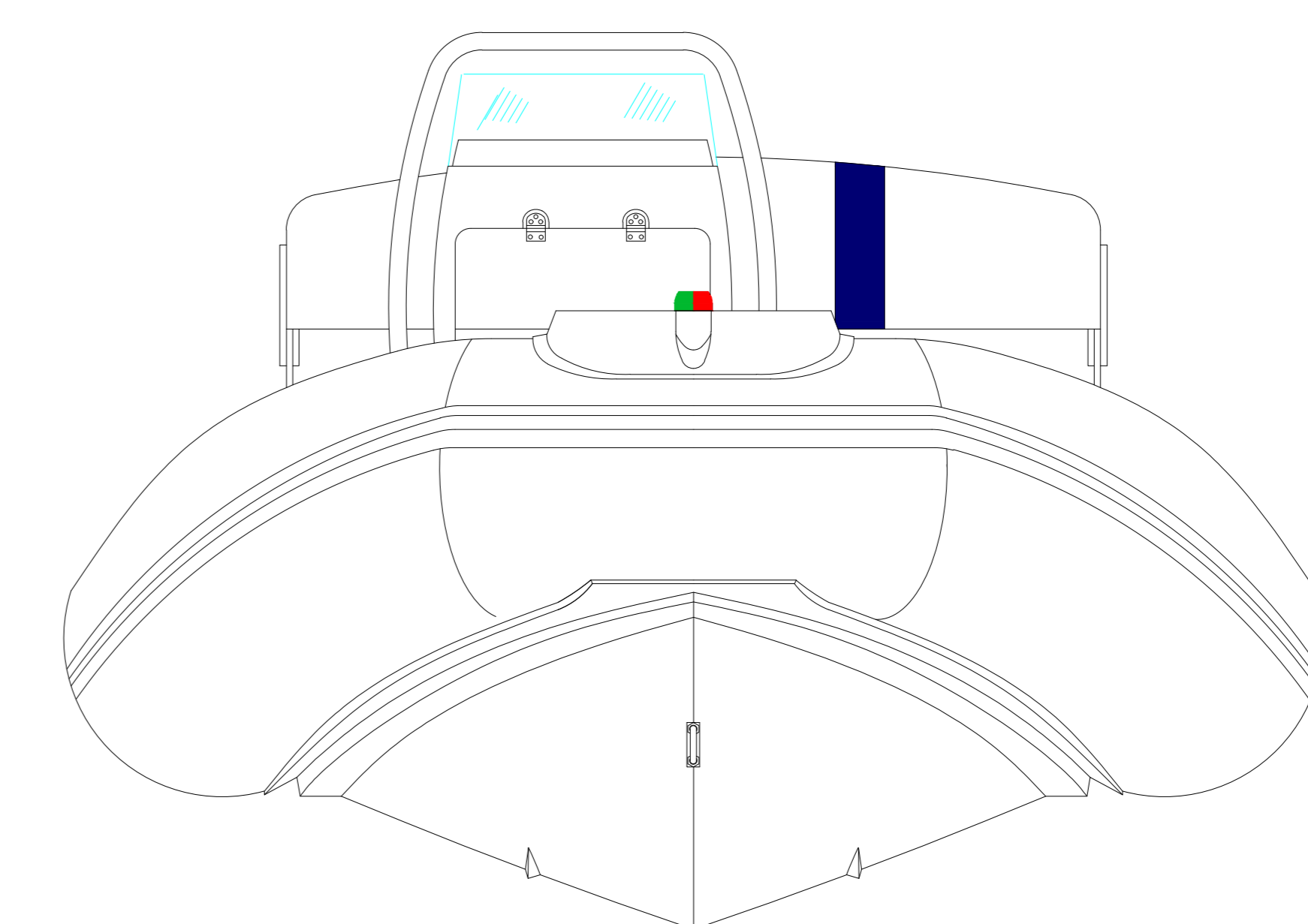

FORE VIEW  
VISTA FRONTAL

**MAIN PARTICULARS**

MAXIMUM LENGHT/ESLORA MAX. \_\_\_\_\_ 12' (3.66m)  
 MAXIMUM BEAM/MANGA MAX. \_\_\_\_\_ 6' 1" (1.86m)

**NOTES:** 1.-ALL DIMENSIONS IN INCHES  
 TODAS LAS MEDIDAS ESTAN DADAS EN PULGADAS

SUBJECTED: <b>JAVIER NORIEGA</b> APPROVED: <b>HERMES GARCIA</b>		TITLE: <b>"OCEANUS 12 VST "</b> <b>GENERAL ARRANGEMENT</b> <b>ARREGLO GENERAL</b>				 DATE: <b>07.01.22</b> DRAWN: <b>HECTOR SUAREZ</b> DATE: _____ APPROVED: _____	
		SCALE:	SHEET: <b>1/1</b>	CODE:	PLAN:		