

MEASUREMENTS BASED ON YAMAHA'S AVAILABLE INFORMATION AND STANDARD HEIGHT OF INSTALLATION. VERIFICATION IS ADVISED

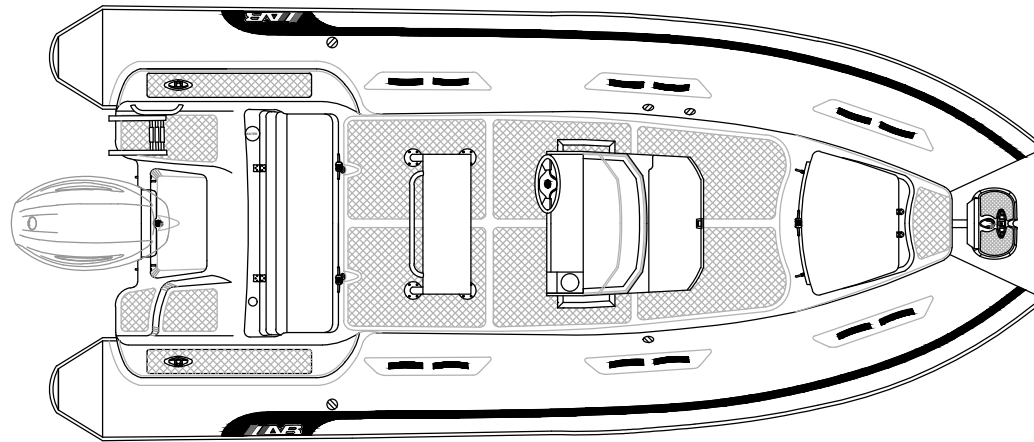

**PLANT VIEW**

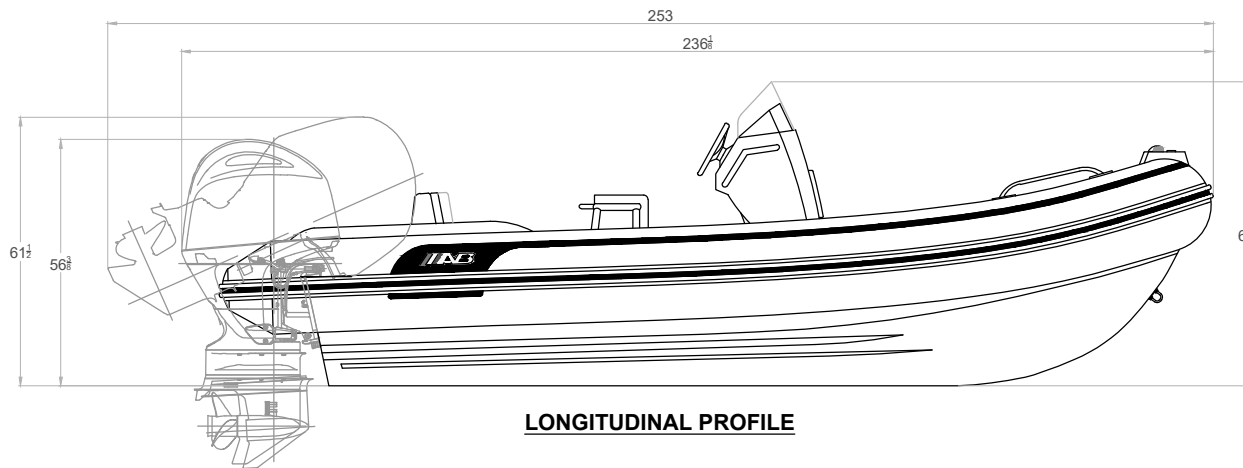

**LONGITUDINAL PROFILE**

**MAIN PARTICULARS**

MAXIMUM LENGHT/ESLORA MAX. \_\_\_\_\_ 19' (5.79m)  
 MAXIMUM BEAM/MANGA MAX. \_\_\_\_\_ 8' 4" (2.54m)

**NOTES:** 1.-ALL DIMENSIONS IN INCHES

SUBJECTED: JAIRO MARTINEZ APPROVED: HERMES GARCIA		TITLE: "OCEANUS 19 VST - YAMAHA 150 HP"  <b><u>GENERAL ARRANGEMENT</u></b>				 DATE 01.08.25 DRAWN HECTOR SUAREZ	
		SCALE.	SHEET: 1/1	CODE:	PLAN:		

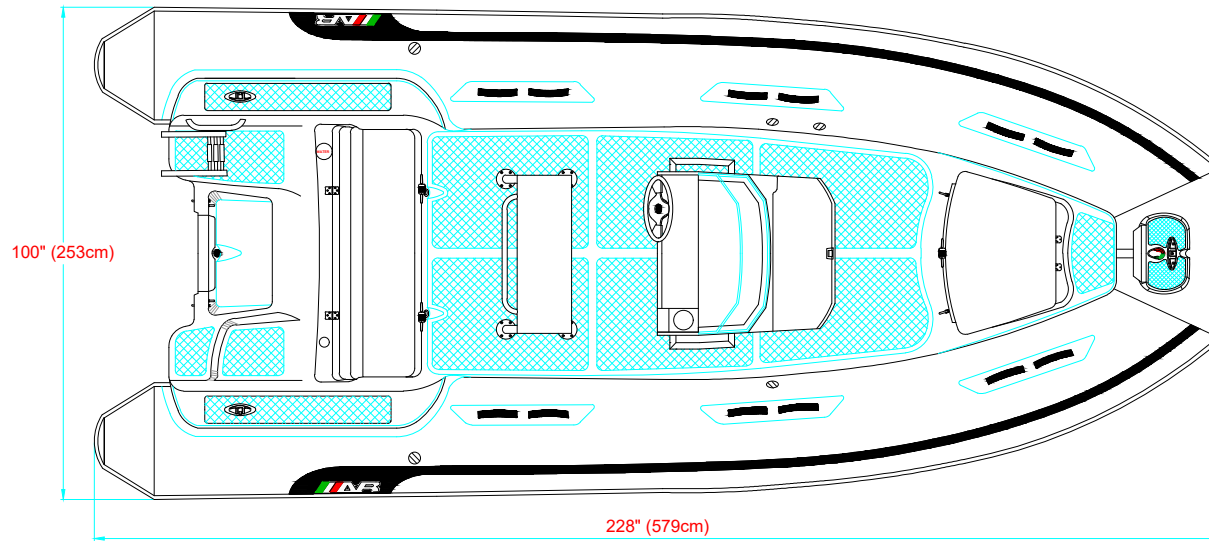

**PLANT VIEW**  
**VISTA SUPERIOR**

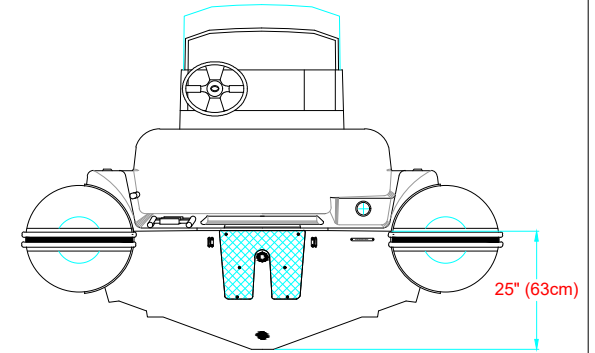

**AFT VIEW**  
**VISTA TRASERA**

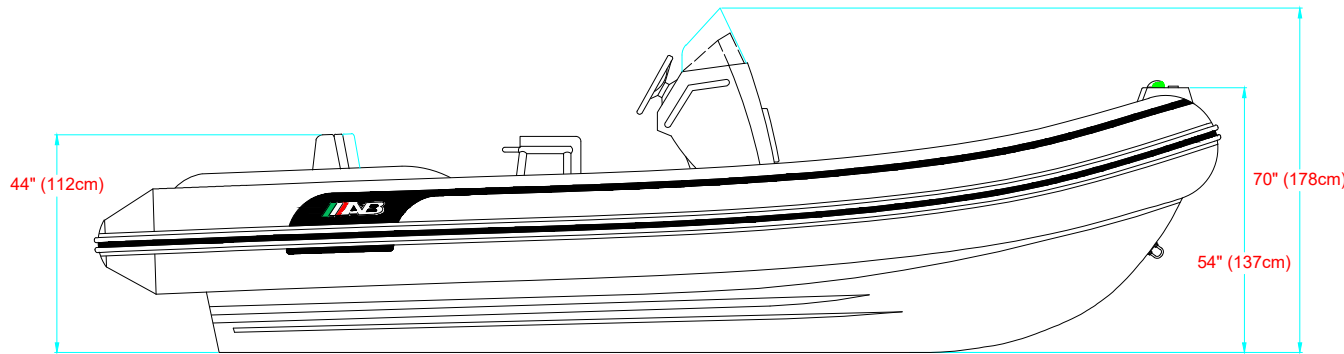

**LONGITUDINAL PROFILE**  
**VISTA LATERAL**

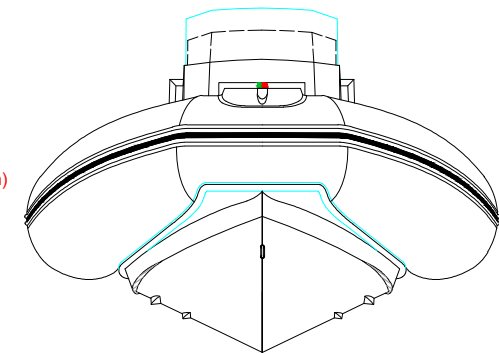

**FORE VIEW**  
**VISTA FRONTAL**

**MAIN PARTICULARS**

MAXIMUM LENGTH/ESLORA MAX. \_\_\_\_\_ 19' (5.79m)  
 MAXIMUM BEAM/MANGA MAX. \_\_\_\_\_ 8' 4" (2.53m)

**NOTES:** 1.-ALL DIMENSIONS IN INCHES & CENTIMETERS  
 TODAS LAS MEDIDAS ESTAN DADAS EN PULGADAS Y CENTIMETROS

		TITLE: " OCEANUS 19 VST " <b>GENERAL ARRANGEMENT</b> <b>ARREGLO GENERAL</b>						
SUBJECTED: JAIRO MARTINEZ APPROVED: HERMES GARCIA		SCALE:	SHEET: 1/1	CODE:	PLAN:			No.REV 7