

WAECO

by Dometic GROUP



WAECO ColdMachine 54, 55, 84, 85, 86, 87, 94, 95, 96, 97, CS-NC15

DE 13 Kühlaggregat
Bedienungsanleitung

EN 35 Cooling unit
Operating manual

FR 56 Groupe frigorifique
Notice d'utilisation

ES 80 Unidad frigorífica
Instrucciones de uso

IT 103 Gruppo refrigerante
Istruzioni per l'uso

NL 126 Koelaggregaat
Gebruiksaanwijzing

DA 148 Køleaggregat
Betjeningsvejledning

SV 169 Kylaggregat
Bruksanvisning

NO 190 Kjøleaggregat
Bruksanvisning

FI 211 Jäähdytysagregaatit
Käyttöohje

RU 232 Холодильный агрегат
Инструкция по эксплуатации

PL 257 Agregat chłodzący
Instrukcja obsługi

CS 279 Chladicí agregát
Návod k obsluze

SK 300 Chladiaci agregát
Návod na obsluhu

1

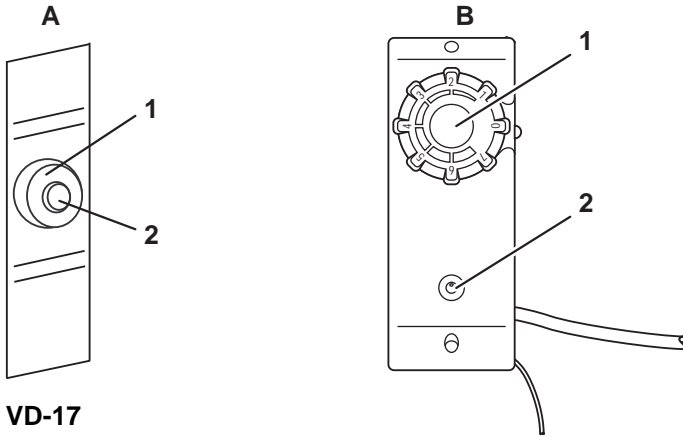

2

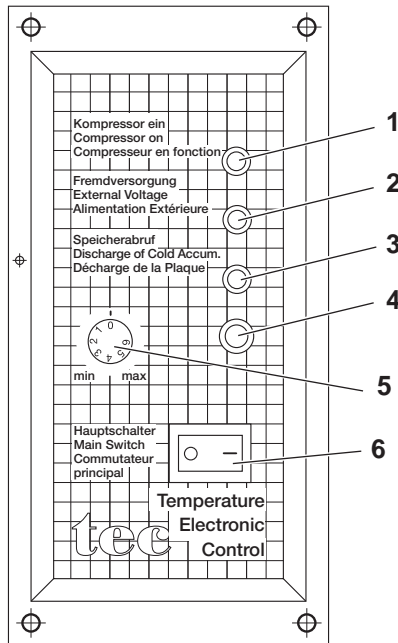

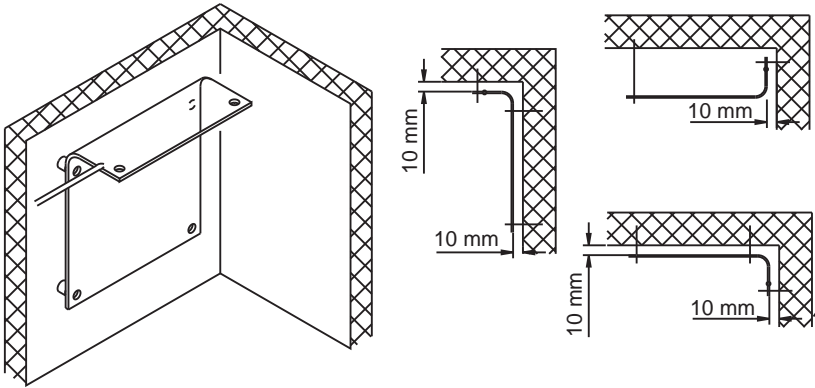
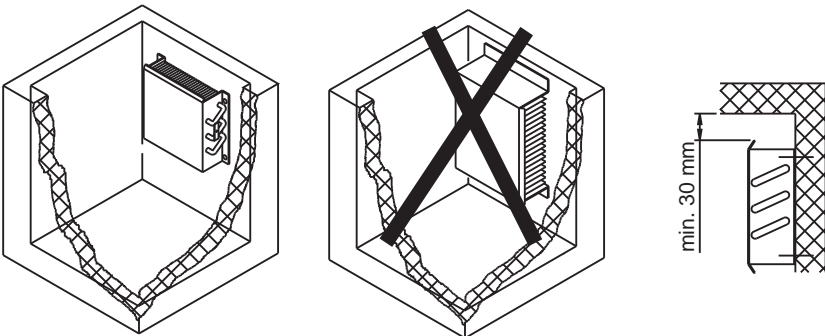
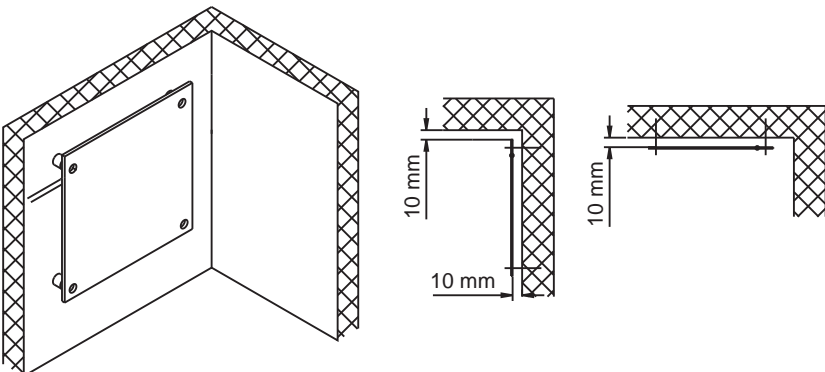
3 VD-01, VD-04, VD-08**4** VD-03**5** VD-02, VD-05, VD-18, VD-21

6 VD-06

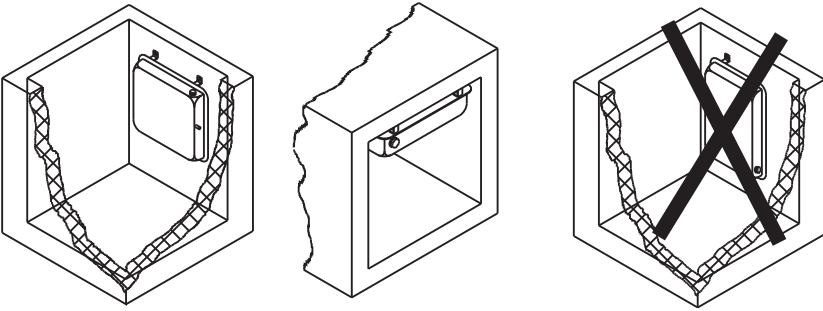

7 VD-07, VD-09

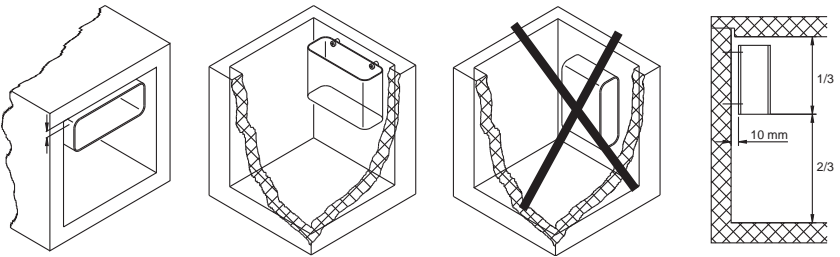

8 VD-14N, VD-15

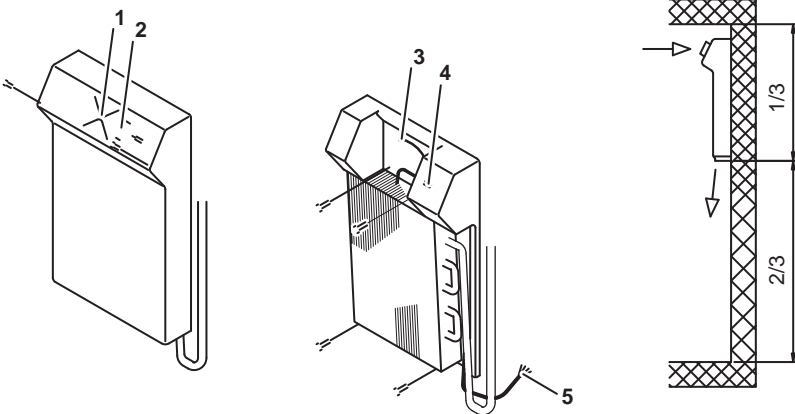

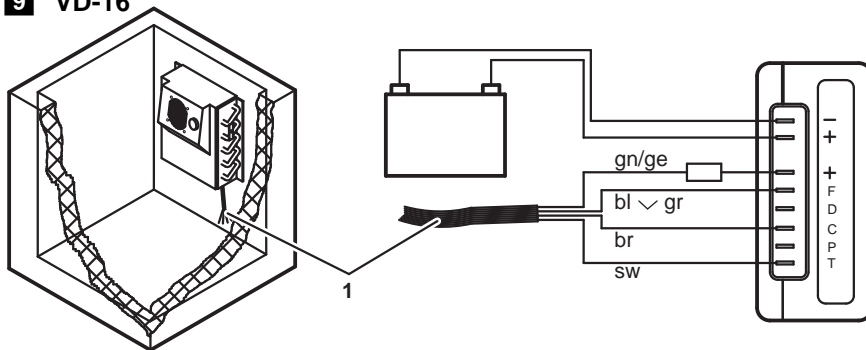
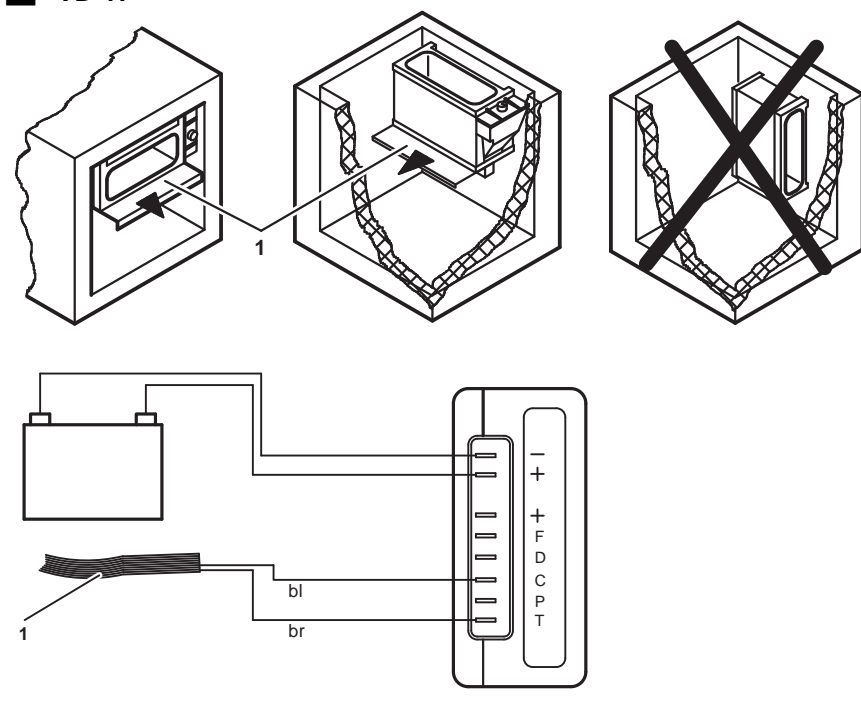
9 VD-16**10** VD-17

11

VD-14N, VD-15

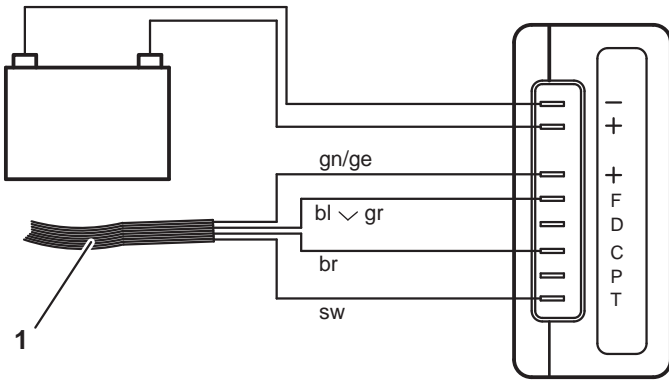

12

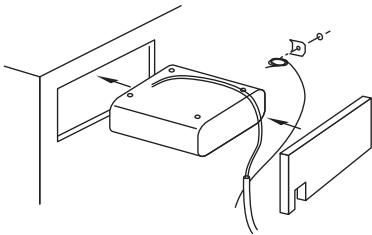

13

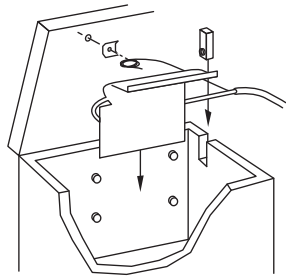

14

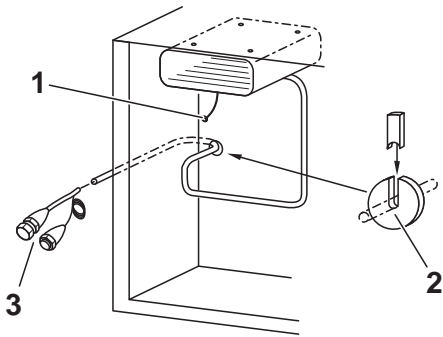

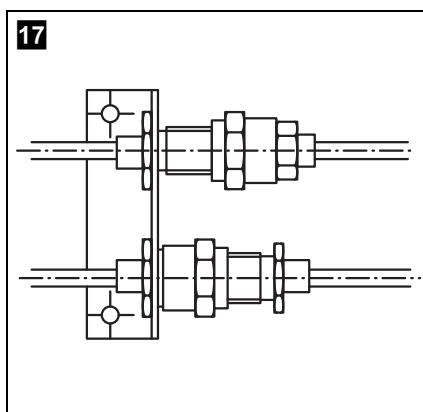
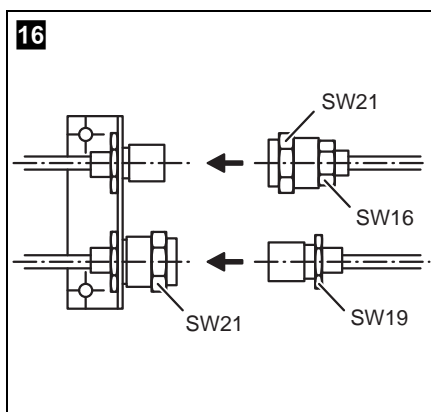
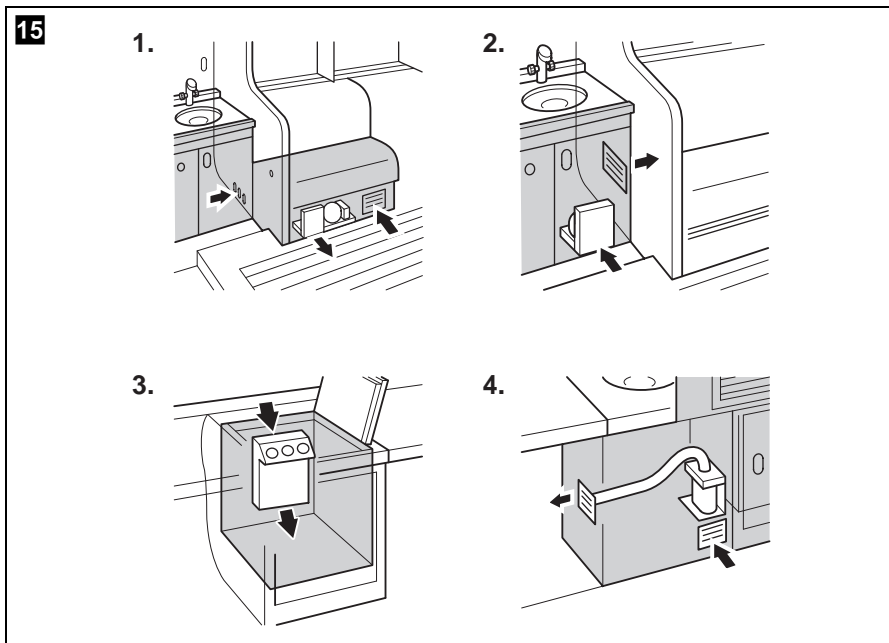

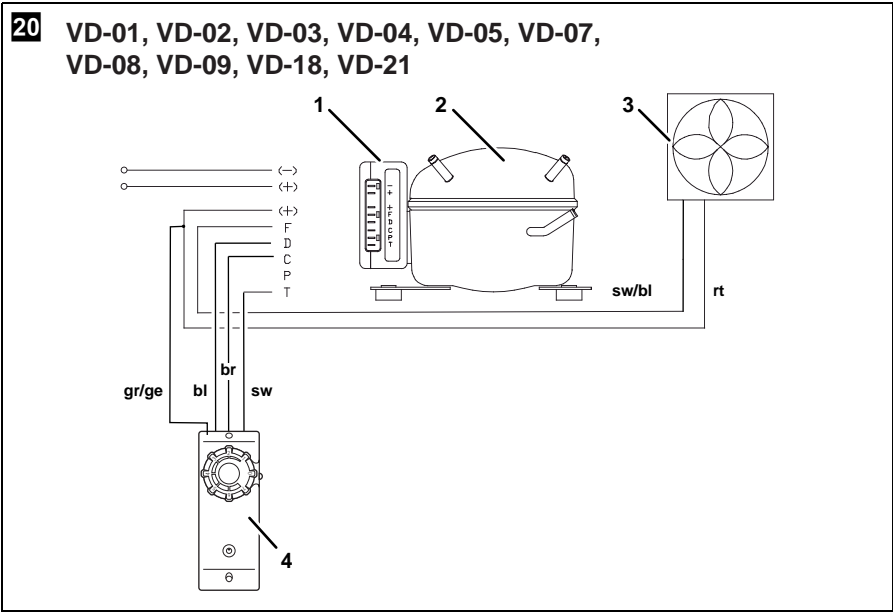
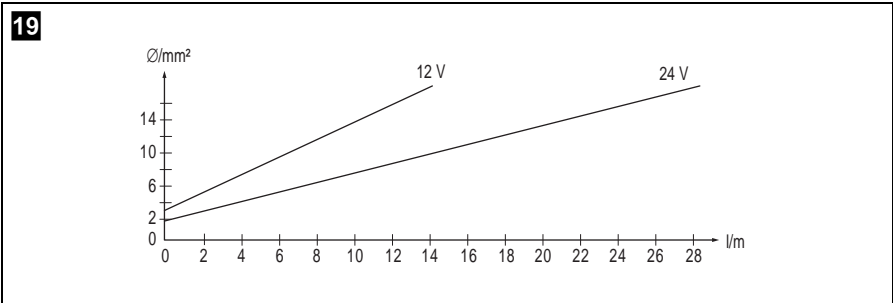
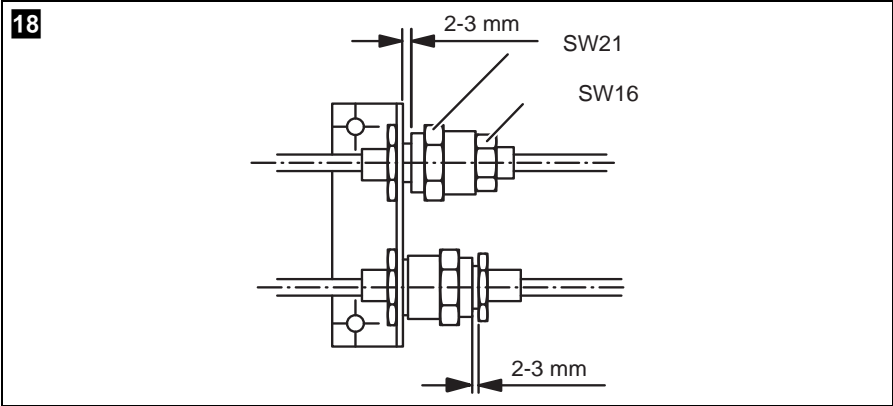

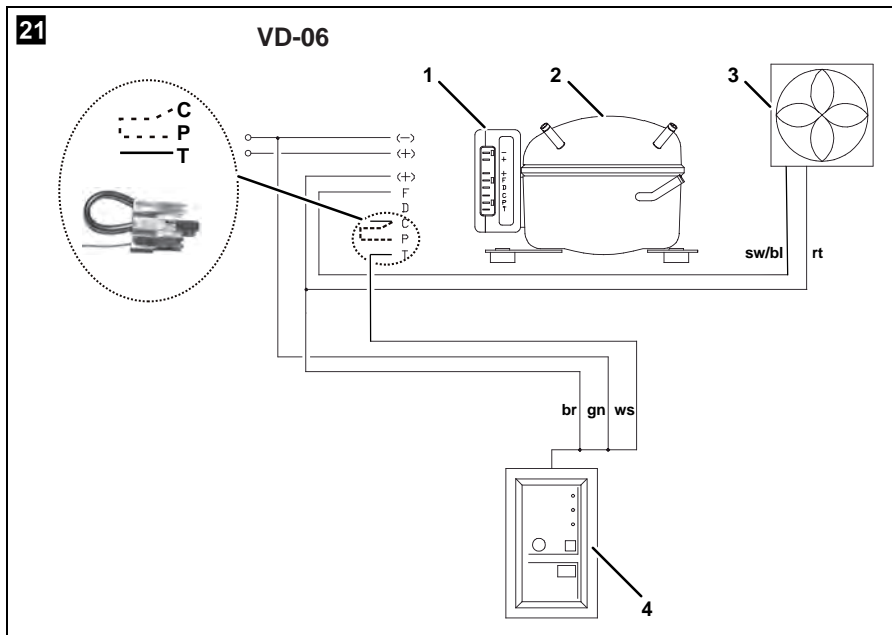

	bl	br	gn	gr	rt	sw	ws	∨
DE	Blau	Braun	Grün	Grau	Rot	Schwarz	Weiß	oder
EN	Blue	Brown	Green	Grey	Red	Black	White	or
FR	Bleu	Marron	Vert	Gris	Rouge	Noir	Blanc	ou
ES	Azul	Marrón	Verde	Gris	Rojo	Negro	Blanco	o bien
IT	Blu	Marrone	Verde	Grigio	Rosso	Nero	Bianco	oppure
NL	Blauw	Bruin	Groen	Grijs	Rood	Zwart	Wit	of
DA	Blå	Brun	Grøn	Grå	Rød	Sort	Hvid	eller
SV	Blå	Brun	Grön	Grå	Röd	Svart	Vit	eller
NO	Blå	Brun	Grønn	Grå	Rød	Svart	Hvit	eller
FI	Sininen	Ruskea	Vihreä	Harmaa	Punainen	Musta	Valkoinen	tai
RU	Синий	Коричне- вый	Зеленый	Серый	Красный	Черный	Белый	или
PL	Niebieski	Brazowy	Zielony	Szary	Czer- wony	Czarny	Bialy	lub
CS	Modrá	Hnědá	Zelená	Šedá	Červená	Černá	Bílá	nebo
SK	Modrá	Hnedá	Zelená	Sivá	Červená	Čierna	Biela	alebo

22

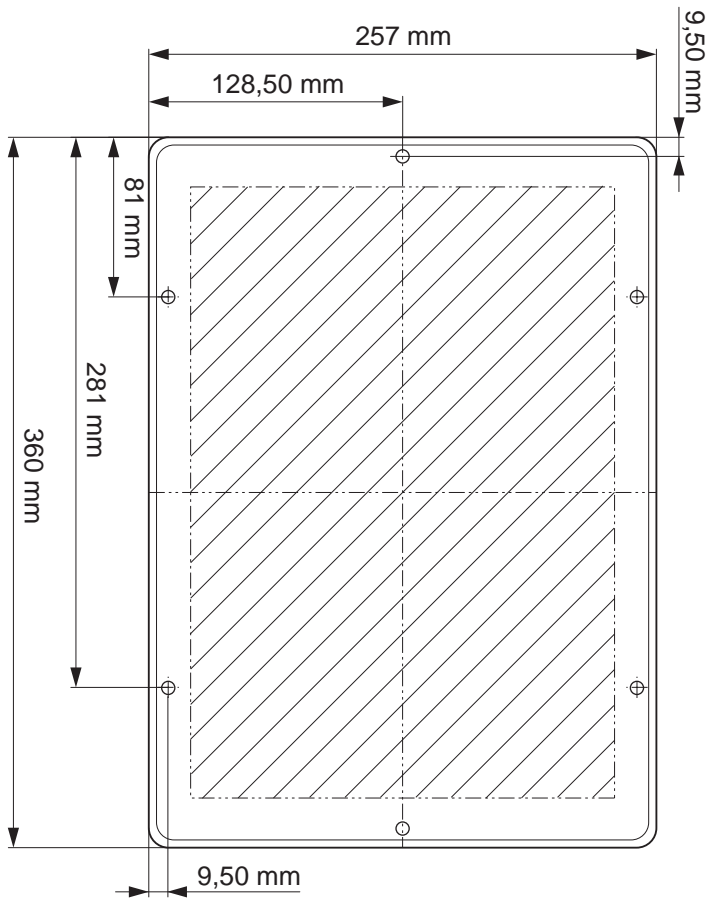

23

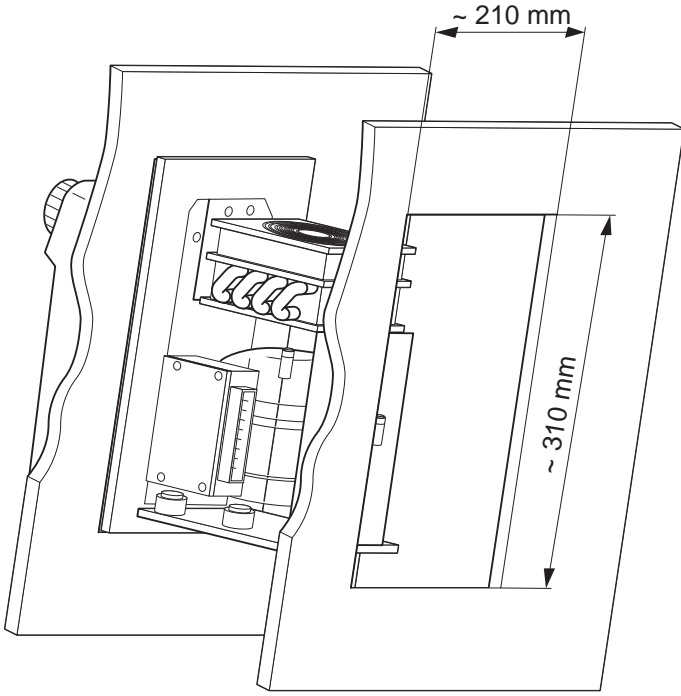

**NOTICE!**

Failure to observe this instruction can cause material damage and impair the function of the product.

**NOTE**

Supplementary information for operating the product.

► **Action:** This symbol indicates that action is required on your part. The required action is described step-by-step.

✓ This symbol describes the result of an action.

fig. 1 5, page 3: This refers to an element in an illustration. In this case, item 5 in figure 1 on page 3.

2 Safety instructions

The manufacturer accepts no liability for damage in the following cases:

- Faulty assembly or connection
- Damage to the product resulting from mechanical influences and excess voltage
- Alterations to the product without express permission from the manufacturer
- Use for purposes other than those described in the operating manual

2.1 General safety

**DANGER!**

- **Danger of fatal injuries!**

When using the device on boats: if the device is powered by the mains, ensure that the power supply has a residual current circuit breaker!

**WARNING!**

- Have a trained technician make installations in wet rooms.
- Do not operate the device if it is visibly damaged.
- This device may only be repaired by qualified personnel. Inadequate repairs can lead to considerable hazards. Should your device need to be repaired, please contact customer services.

- Do not open the refrigerant circuit under any circumstances. An exception to this is when the device has to be disconnected for return shipping (“Installing the external temperature regulator” on page 43).
- Set up the device in a dry location where it is protected against splashing water.
- Do not place the device near naked flames or other heat sources (heaters, direct sunlight, gas ovens etc.).
- Make sure that the compressor is sufficiently ventilated.
- **Electronic devices are not toys!**
Always keep and use the device out of the reach of children.
- People (including children) whose physical, sensory or mental capacities or whose lack of experience or knowledge prevent them from using this product safely should not use it without the supervision or instruction of a responsible person.
- Before you start up the device for the first time, check that the operating voltage matches the battery voltage (see type plate).
- If the connection cable is damaged, it must be replaced to prevent possible electrical hazards. Only replace a damaged connection cable with a connection cable of the same type and specifications.
- Do not store any explosive substances, such as spray cans with propellants in the device.

2.2 Operating the device safely



DANGER! Danger of fatal injuries!

- Do not touch exposed cables with your bare hands. This especially applies when operating the device from the AC mains.



NOTICE!

- Never use cleaners that contain sand, acids or solvents to clean the vaporiser.
- Protect the device against rain and moisture.
- Disconnect the cooling device and other consumer units from the battery before you connect the quick charging device.

**NOTE**

- Disconnect the device if you are not going to use it for a prolonged period.

2.3 Safety precautions when handling batteries

**CAUTION! Danger of injury!**

- Batteries contain aggressive and caustic acids. Avoid battery fluid coming into contact with your body. If your skin does come into contact with battery fluid, wash the part of your body in question thoroughly with water.
- If you connect the device to a battery, make sure that no food comes into contact with the battery acid.

3 Scope of delivery

Quantity	Description
1	Cooling unit or vaporiser
1	Operating manual

3.1 Accessories

If you wish to operate the cooling unit from the 230 V AC mains, please use one of the following rectifiers.

Available as accessory (not included in scope of delivery):

Description	Item number
WAECO rectifier For devices with Bd-35F compressor (50/80/CS series)	EPS-100W
WAECO rectifier For devices with Bd-35F compressor (50/80/CS series)	MPS-35
WAECO rectifier For devices with Bd-50F compressor (90 series)	MPS-50

4 Intended use

The cooling unit is suited for building your own refrigerator or cooler.



The cooler unit is suitable for cooling and freezing food. The device is also suitable for use on boats.



CAUTION! Health hazard!

Please check if the cooling capacity of the device is suitable for storing the food or medicine you wish to cool.

5 Technical description

The cooling units are suitable for use with 12 V or 24 V DC voltage and can therefore be used for camping or on boats. Furthermore, you can connect them to a 230 V mains supply via the WAECO rectifiers (see “Accessories” on page 38).

When used on boats, the cooling unit can withstand a constant heeling of 30°.

The cooling unit must be used together with a vaporiser. In addition, you can use an accumulator with or without TEC control. The **CS-NC15** comprises a cooling unit and a vaporiser.

Use the continuously variable thermostat on the vaporiser to set the desired temperature.

The accumulator and TEC program control ensure a high cooling capacity and improve the unit's efficiency. The accumulator is charged when there is a sufficient supply of power (for example when powered by a mains adapter). In the event of accumulator usage or under-voltage, the coolant is drawn from the accumulator until it is empty. Thus, no power is taken from the battery during this time.

The TEC program control always ensures that

- Cold energy is stored if there is excess electrical energy (external supply of power by a generator).
- The coolant accumulator can be used at any time to ensure that the complete battery power is used for other consumers.
- Stored cold energy is automatically retrieved to preserve the interior cooling temperature of the cooling area, once the battery capacity is exhausted.

**NOTE**

Further information on the coolant accumulator can be found in “Use coolant accumulator” on page 48.

5.1 Battery monitor

The cooling device is equipped with an electronic device to protect against reversing the polarity when connecting to a battery. To protect the battery, the cooling device switches off automatically if the voltage is insufficient (see following table).

Devices without TEC control

Connection voltage	Switch-off voltage	Restart voltage
12 V	10.4 V	11.7 V
24 V	22.8 V	24.2 V

Devices with TEC control

Connection voltage	Switch-off voltage	Restart voltage
12 V	10.7 V	13.0 V
24 V	22.0 V	26.0 V

6 Installing the cooling unit

6.1 Notes on the cooling container

Permitted cooling area contents

Make sure that maximum cooling area contents specified are not exceeded for the respective vaporiser type (see “Technical data” on page 53).

Minimum insulation

The maximum cooling area contents are based on a minimum insulation thickness of 35 mm of foam polyurethane with a density of 40 kg/m³. If other insulating materials are used such as styrofoam, double the wall thickness to attain the same level of heat insulation.

Installing the vaporiser

The vaporiser must be installed in the cooling container (except **CS-NC15**, the vaporiser is premounted).

- Observe the following in the process:
 - Correct installation position (fig. **3**, page 4 up to fig. **10**, page 6)
 - Arrangement in the cooling container as far to the top as possible
 - Install a least 10 mm from the wall (**not VD-14N and VD-15**).



NOTICE!

For cooling units without valve couplings (ready-to install units): Do not open the refrigerant circuit during installation. You may have to make the wall openings larger to be able to slide the vaporiser through them (fig. **12**, page 7). Or alternatively, you create an opening that allows you to install the cooling lines at the top (fig. **13**, page 7).

Connecting the vaporiser

- Connect the vaporisers **VD-14N and VD-15** in accordance with fig. **11**, page 7.
- Connect vaporiser **VD-16** according to fig. **9**, page 6.
- Connect vaporiser **VD-17** according to fig. **10**, page 6.
- Connect vaporiser **VD-06** according to fig. **21**, page 10.
- Connect other vaporisers according to fig. **20**, page 9.

Keys for the illustrations

No. in fig. 8 , page 5	Explanation
1	DC fan
2	Thermostat button
3	Connection plug for DC fan
4	Thermostat
5	Connection cable

No. in fig. 9 , page 6	Explanation
1	Connection cable

No. in fig. 10 , page 6	Explanation
1	Drip tray

No. in fig. 11 , page 7	Explanation
1	Connection cable

No. in fig. 20 , page 9 and fig. 21 , page 10	Explanation
1	Connection block
2	Compressor
3	Fan
4	Switch fig. 20 or TEC controller fig. 21

**NOTICE!**

Carefully insulate and seal off the wall openings after installation to prevent moisture penetration.

For cooling units with valve couplings

- ▶ Cut out a hole with a diameter of at least 30 mm (fig. **14**, page 7) for the cooling lines. To do this, use a circular cutter.

**NOTICE!**

Never bend the connecting line between the vaporiser and the unit. The minimum bending radius is 25 mm.

6.2 Installing the cooling unit

It is important to select the proper location for setting up the unit. To ensure trouble-free operation, please note the following points:

- Set up the cooling unit in a dry, sheltered place. Avoid placing it near heat sources such as radiators, gas ovens or hot water pipes. Do not place in direct sunlight.
- On a boat, install the cooling unit, if possible, below the waterline.
- The heated air must dissipate unhindered (fig. **15**, page 8).
- When installing the cooling unit in a closed room such as a wardrobe, pantry or aft compartment, openings must have a cross section of at least 200 cm² (25 cm x 8 cm) for cooling and exhaust air.
- Make sure that the air flow on the condenser (fig. **15** 3, page 8) is not restricted.
- Maintain a minimum distance between the condenser and adjoining wall of 50 mm.
- **CS-NC15**: Observe the drilling template (fig. **22**, page 11) and the installation drawing (fig. **23**, page 12).

6.3 Installing the external temperature regulator

Mechanical thermostat

The temperature regulator can be mounted either on the outside or inside of the cooling container. The interior temperature is regulated depending on the surface temperature of the vaporiser, or **for VD-14N and VD-15**, depending on the room temperature.

- Connect the coiled end of the sensor cable to the vaporiser (**not VD-14N, VD-15**) using the clamping plate. This is premounted on **VD-14N, VD-15**.
- Make sure that the sensor line does not make contact anywhere else with the vaporiser or with the suction line.

TEC control

The TEC control must be attached outside of the cooling container. The internal temperature is regulated according to the vaporiser surface temperature.

The temperature sensor has been factory-mounted to the accumulator.

- Connect the temperature sensor with the TEC control via the plug-in coupling.

Mount the one-way couplings (not CS-NC15)

The cooling unit is delivered in a disconnected state (the vaporiser and compressor are separated); however, it has been filled at the factory with the proper amount of coolant.

- Install the machine part and the vaporiser.
- Remove the screwed-on caps from the coupling halves that protect the rubber seal from dirt.

The fig. **16**, page 8, shows the condition of the coupling halves after removing the caps when uncoupled.

- Place the coupling halves by hand on top without tension and tighten them by hand (fig. **17**, page 8).

If the position in fig. **18**, page 9 has been reached (2–3 mm distance between both coupling halves), the coupling has not yet been tightened. The coupling only has rubber seals to prevent the loss of coolant. They do not provide long-term protection against leakage.



NOTE

Always use two open-ended spanners to prevent both couplings in the coupling holder from turning.

Tools required:

- Open-ended spanner: Width 21 for tightening the coupling
- Open-ended spanner: Width 19 and 16 for holding the counter-coupling in place



NOTICE!

If you do not hold the counter-coupling in place when tightening the coupling or do not tighten it further by 90°, coolant will leak unnoticeably and eventually lead to system failure.

In such cases, the complete cooling unit must be disassembled, returned, the one-way couplings replaced and the device refilled at the factory.

- Tighter the union nuts of the female coupling halves further by another 90° using open-ended spanners.
- ✓ The final, metallic and long-term, absolute gas tightness is now ensured, since the cutting ring of the male coupling half has cut into the face of the female half.

**WARNING!**

The coolant in the system is under pressure.
Wear safety goggles and gloves when disconnecting.

If the device must be decoupled for return shipping, make sure to screw the caps back onto the coupling halves to prevent dirt and moisture from entering the refrigerant circuit.

6.4 Connecting the cooling unit

Connecting to a battery

The cooling unit can be operated from a 12 V or a 24 V DC voltage supply.

**NOTICE!**

To avoid voltage loss and therefore a drop in performance, the cable should be kept as short as possible and should not be interrupted.

For this reason avoid additional switches, plugs or power strips.

- ▶ Determine the required cross section of the cable in relation to the cable length according to fig. **19**, page 9.

Key for fig. **19**, page 9

Co-ordinate axis	Meaning	Unit
I	Cable length	m
∅	Cable cross section	mm ²

**NOTICE!**

Make sure that the polarity is correct.

- ▶ Before you start up the unit for the first time, check that the operating voltage matches the battery voltage (see type plate).
- ▶ Connect your cooling unit
 - as directly as possible to the pole of the battery or
 - to a plug socket which is fuse protected with at least 15 A (at 12 V) or 7.5 A (at 24 V).

**NOTICE!**

Disconnect the cooling device and other power consuming devices from the battery before you connect the battery to a quick charging device. Overvoltage can damage the electronics of the device.

For safety reasons the cooling unit is equipped with an electronic system to prevent polarity reversal. This protects the cooling unit when it is connected to a battery.

Connecting to a 230 V mains supply**WARNING!**

- Never handle plugs and switches with wet hands or if you are standing on a wet surface.
- If you are operating your cooling device on board a boat with a mains connection of 230 V from the land, you must install a residual current circuit breaker between the 230 V mains supply and the cooling device.
Seek advice from a trained technician.

- To operate the cooling unit from the 230 V mains, use the WAECO rectifier
- EPS-100W for devices with Bd-35F compressor (50/80/CS series),
 - MPS-35 for devices with Bd-35F compressor (50/80/CS series),
 - MPS-50 for devices with Bd-50F compressor (90 series).

**NOTE**

The output voltage of the described rectifier is 24 V. Please remember this when connecting other consumers at a later time.

7 Using the cooling unit

7.1 Energy saving tips

- Choose a well ventilated installation location which is protected from direct sunlight.
- Allow hot food to cool down first before placing it in the device.
- Do not open the refrigerated container more often than necessary.
- Do not leave the door open for longer than necessary.
- Defrost the refrigerated container once a layer of ice forms.

- Avoid unnecessary low temperatures.
- Clean the condenser of dust and dirt at regular intervals.
- Clean the lid seal regularly.

7.2 Start the cooling unit

Devices without TEC control

- Switch in the cooling unit by turning the control button clockwise (fig. **1** A1 or B1, page 3).

If you turn the control button further, you can regulate the temperature. Devices with energy storage function offer a storage activation button (fig. **1** A2, page 3).



NOTE

If the red LED flashed or glows, a fault has occurred and the system cannot be operated (see error table in Chapter “LED on the thermal element (fig. **1** 2, page 3)” on page 50).

Devices with TEC control

Devices with TEC control are started by actuating the main switch (fig. **2** 6, page 3). You can then regulate the temperature (fig. **2** 5, page 3) with the temperature selector.

7.3 Shutting down the cooling unit

If you do not intend to use the cooling device for a prolonged period, proceed as follows:

- **Devices without TEC control:** Turn the control to 0.
- **Devices with TEC control:** Switch off the device with the main switch (fig. **2** 6, page 3).
- Disconnect the power cable from the battery or pull the DC cable plug out of the rectifier.
- Clean the cooling device.
- Leave the door slightly open over the cover.
This prevents odour build-up.

8 Use coolant accumulator

8.1 Display and control elements of devices with TEC program control

No. in fig. 2, page 3	Explanation
1	Green LED: Indicates that the compressor is working.
2	Yellow LED: indicates that the external power supply is present (voltage is higher than 13.5 V or 27.0 V). The LED flashes if the external power supply is too low (voltage ≤ 10.7 V or 21.7 V. Version E: ≤ 10.7 V or 22.0 V).
3	Red LED: indicates that the accumulator is being discharged because <ul style="list-style-type: none"> ● the discharge button has been pressed ● Low voltage shutdown (voltage ≤ 10.7 V or 21.4 V. Version E: ≤ 10.7 V or 22.0 V).
4	Accumulator discharge button: interrupts compressor operation until <ul style="list-style-type: none"> ● the stored cold energy is exhausted ● The external supply voltage level is restored after low voltage.
5	Temperature selector: allows the temperature in the cooling area to be set as required Min. (left limit) = warmest setting Max. (right limit) = coldest setting
6	Main switch: for switching the cooling device on and off. Position 0 = OFF Position - = ON

8.2 Accumulator function

The accumulator function ensures that cold energy is stored automatically (up to 8 hours) if enough electrical power is available, for example when supplied by a mains adapter.

Stored cooling power is discharged

- automatically when the switch-off voltage is reached (see the table on page 40)
- or manually by pressing the discharge button (fig. **1** A2 or fig. **2** 4, page 3).

**NOTE**

The cold accumulator can only be discharged manually if it was fully charged beforehand.

The accumulator is automatically charged if,

- the restart voltage is exceeded
- or the accumulator is empty and you switch the device off and on again using the control button (fig. **2** 6, page 3, does only function on VD-06).

**NOTICE!**

When you are discharging the accumulator, although there is an external supply of power – for example to avoid operating noise from the compressor – use the main switch to switch the unit off (fig. **1** B1 or fig. **2** 6, page 3).

**NOTE**

Please remember: Low internal temperature = high current consumption!

9 Guarantee

The statutory warranty period applies. If the product is defective, please contact the manufacturer's branch in your country (see the back of the instruction manual for the addresses) or your retailer.

For repair and guarantee processing, please include the following documents when you send in the device:

- A copy of the receipt with purchasing date
- A reason for the claim or description of the fault

10 Disposal

- Place the packaging material in the appropriate recycling waste bins wherever possible.



If you wish to finally dispose of the product, ask your local recycling centre or specialist dealer for details about how to do this in accordance with the applicable disposal regulations.

11 Troubleshooting

LED on the thermal element (fig. **1** 2, page 3)

Number of flashes	Error type	Remedy
1	Battery protection shutdown	Check battery voltage, fuse and cable cross section
2	Fan overvoltage shutdown	Check condenser and vaporiser fan current: total target value < 0.5 A
3	Compressor start-up fault	Reduce load on cooling system: – Ensure good ventilation around the cooling unit – Store pre-cooled goods
4	Compressor overload shutdown	Reduce load on cooling system: – Ensure good ventilation around the cooling unit – Store pre-cooled goods
5	Electronic fuse shutdown	Reduce load on cooling system: – Ensure good ventilation around the cooling unit

Compressor does not run

Fault	Possible cause	Remedy
$U_T = 0 \text{ V}$	The connection between the battery and the – electronics is interrupted	Establish a connection
	Main switch defective (if installed)	Replace the main switch
	Additional supply line fuse has blown (if installed)	Replace the fuse
$U_T \leq U_{ON}$	Battery voltage is too low	Charge the battery
Start attempt with $U_T \leq U_{OFF}$	Loose cables	Establish a connection
	Poor contact (corrosion)	
	Battery capacity too low	Replace the battery
	Cable cross section too low	Replace the cable (fig. 19, page 9)
Start attempt with $U_T \geq U_{ON}$	Ambient temperature too high	–
	Insufficient ventilation and/or cooling	Provide improved ventilation for the cooling unit
	Condenser is dirty	Clean the condenser
	Fan defective (if installed)	Replace the fan

U_T Voltage between the positive and negative electronic terminals

U_{ON} Switch-on voltage of the electronics

U_{OFF} Switch-off voltage of the electronics

Interior temperature too low in control setting 1

Fault	Possible cause	Remedy
Compressor runs constantly	Thermostat sensor has no contact on the vaporiser	Secure the sensor
	Thermostat defective	Change the thermostat
Compressor runs for a long time	Large quantities have been frozen in the freezer compartment	–

Cooling capacity drops, interior temperature rises

Fault	Possible cause	Remedy
Compressor runs for a long time/continuously	Vaporiser is iced over	Defrost the vaporiser
	Ambient temperature too high	–
	Insufficient ventilation and/or cooling	Provide improved ventilation for the cooling unit
	Condenser is dirty	Clean the condenser
	Fan defective (if installed)	Replace the fan
Compressor runs infrequently	Battery capacity exhausted	Charge the battery

Unusual noises

Fault	Possible cause	Remedy
Loud humming	A component of the refrigerant circuit cannot move freely (lies against the wall)	Bend the component carefully away from the obstruction
	Foreign body jammed between the cooling device and the wall	Remove the foreign body
	Fan noise (if installed)	Clean the fan blades

12 Technical data

	CU-54	CU-55
Max. cooling area contents:	130 litres	
Connection voltage:	12 V DC or 24 V DC	
Power consumption:	35-40 W, depending on the vaporiser type	
Dimensions (WxHxD) in mm:	386x155x130	220x160x220
Weight:	6.0 kg	6.5 kg

	CU-84	CU-85	CU-86	CU-87
Max. cooling area contents:	250 litres			
Connection voltage:	12 V DC or 24 V DC			
Dimensions (WxHxD) in mm:	386x155x130	220x155x220	220x230x177	310x225x170
Weight:	6.0 kg	6.0 kg	6.5 kg	7.5 kg

	CU-94	CU-95	CU-96	CU-97
Max. cooling area contents:	400 litres			
Connection voltage:	12 V DC or 24 V DC			
Dimensions (WxHxD) in mm:	386x155x130	220x155x220	220x230x177	310x225x170
Weight:	6.0 kg	6.0 kg	6.5 kg	7.5 kg

	CS-NC15
Max. cooling area contents:	250 litres
Connection voltage:	12 V DC or 24 V DC
Dimensions (WxHxD) in mm:	360x255x275
Weight:	8.5 kg

	VD-01	VD-02	VD-03	VD-04
Max. cooling area content at 35 mm PU insulation:	80 litres	30 litres	170 litres	130 litres
Max. cooling area content at 50 mm PU insulation:	100 litres	50 litres	200 litres	170 litres
Power consumption:	35 W	35 W	50 W	45 W
Voltage	12 V DC or 24 V DC			
Dimensions (WxHxD) in mm:	300x245x110	275x215x25	380x230x82	375x255x100
Weight:	1.5 kg	1.0 kg	2.0 kg	1.5 kg
	VD-05	VD-07	VD-08	VD-09
Max. cooling area content at 35 mm PU insulation:	130 litres	100 litres	160 litres	160 litres
Max. cooling area content at 50 mm PU insulation:	170 litres	130 litres	180 litres	180 litres
Power consumption:	45 W	35 W	60 W	60 W
Voltage	12 V DC or 24 V DC			
Dimensions (WxHxD) in mm:	375x350x25	255x210x90	450x270x340	365x140x270
Weight:	1.5 kg	1.5 kg	2.0 kg	2.0 kg
	VD-14N	VD-15	VD-17	VD-18
Max. cooling area content at 35 mm PU insulation:	300 litres	200 litres	80 litres	100 litres
Max. cooling area content at 50 mm PU insulation:	400 litres	250 litres	100 litres	150 litres
Power consumption:	80 W	60 W	40 W	45 W
Voltage	12 V DC or 24 V DC			
Dimensions (WxHxD) in mm:	220x275x65	220x275x65	315x215x125	350x250x25
Weight:	2.5 kg	1.5 kg	3.5 kg	1.5 kg

	VD-16	VD-21
Max. cooling area content at 60 mm PU insulation:	130 litres	250 litres
Max. cooling area content at 100 mm PU insulation:	200 litres	300 litres
Power consumption:	60 W	60 W
Voltage	12 V DC or 24 V DC	
Dimensions (WxHxD) in mm:	330x260x130	1370x305x10
Weight:	2.5 kg	4.0 kg

	VD-16 for series 80	VD-16 for series 90
Max. cooling area content at 35 mm PU insulation:	120 litres	200 litres
Max. cooling area content at 50 mm PU insulation:	200 litres	250 litres
Power consumption:	65 W	80 W
Voltage	12 V DC or 24 V DC	
Dimensions (WxHxD) in mm:	380x300x62	
Weight:	5.0 kg	

Test/certificates:

The coolant circuit contains R-134a.