

Vernatone Round

The Vernatone Round is the original style that has been used by boat builders and boaters worldwide for over 40 years.

Application: All Inboards

Fuel type: Gas/Diesel

Waterline: Above only

Sound rating: Good

Note: for 10"-14" range please reference our Vernatone MKII round or the MKII Dual Stage round.

[Vernatone Installation Sheet](#)

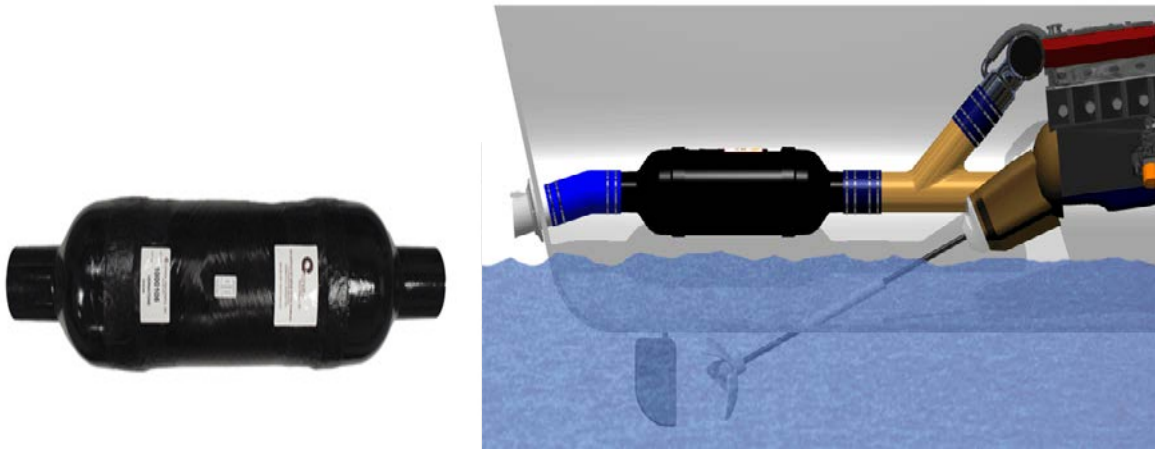

VERNATONE™ ROUND

Part #	A		B		C		D	
	IN/OUT INCHES	MM	I/O LENGTH INCHES	MM	LENGTH INCHES	MM	DIAMETER INCHES	MM
1000103	2.50	64	3.00	76	21.62	549	5.58	142
1000145	3.00	76	3.50	89	20.12	511	7.07	180
1000104	3.00	76	3.50	89	25.84	656	7.07	180
1000105	3.50	89	3.50	89	30.00	762	8.09	205
1000165	4.00	102	3.50	89	25.50	648	9.06	230
1000106	4.00	102	3.50	89	33.69	856	9.06	230
1000107	4.50	114	4.00	102	35.62	905	10.10	257
1000108	5.00	127	4.40	112	38.75	984	11.00	279
1000112	6.00	152	5.00	127	31.43	798	12.20	310
1000111	6.00	152	5.00	127	41.50	1054	12.20	310
1000117	6.00	152	6.00	152	39.62	1006	16.21	412
1000113	6.00	152	6.00	152	52.75	1340	16.21	412
1000245	6.50	165	5.75	146	41.50	1054	12.25	311
1000299	6.63	168	5.75	146	52.75	1340	16.21	412
1000120	8.00	203	6.00	152	39.62	1006	16.21	412
1000119	8.00	203	6.00	152	52.75	1340	16.21	412
1000246	8.50	216	6.00	152	52.75	1340	16.25	413

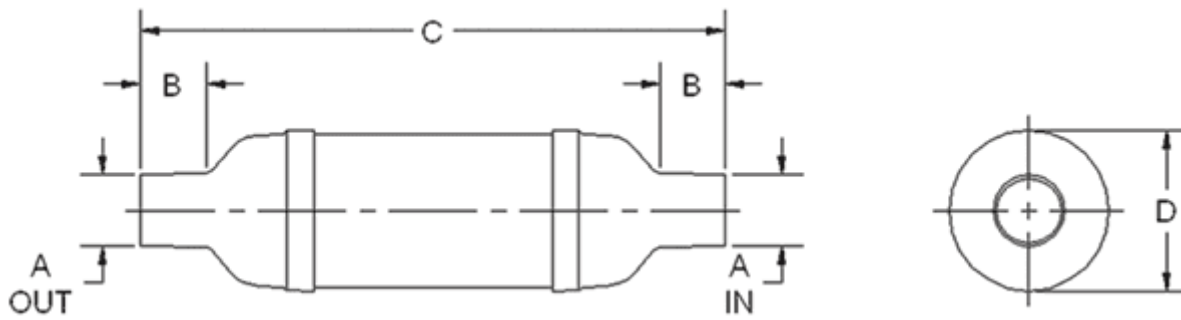

The following table is for general recommendations only:

IN & OUT SIZE / MAXIMUM H.P.		
Dia. A	Gasoline	Diesel
1.50" or 1.63"	30	10
2.00"	60	25
2.50"	110	40
3.00"	160	60
3.50"	220	85
4.00"	280	125
4.50"	320	170
5.00"	370	210
6.00"	440	280
8.00"	--	420
10.00"	--	680
12.00"	--	900
14.00"	--	1150

NOTE: For V-Block engines where twin exhaust lines are desired, divide the H.P. by two and then match to the appropriate size.