



SHURFLO AQUA KING™II SUPREME 5.0 MARINE FRESH WATER PUMP – PRODUCT TECHNICAL DATA SHEET

OEM: 4158-153-A75
AFTERMARKET: 4158-153-E75



APPLICATION:

Multi-fixture Marine adjustable by-pass fresh water pump installation. Other uses may include 12V DC pressurize water systems in cabins. This pump may be used for general fresh water transfer

PUMP DESIGN:

Type: 4 Chamber Diaphragm pump
Ports: ½"-14 NPSM-Male
Liquid: 130°F [54°C] Max
Dry-Prime: 6 feet [1.82 M]
Run Dry: Yes
Inlet Pressure: 30 PSI Max. [2.06 Bar]

ELECTRICAL:

Motor: 12V DC Permanent Magnet, Intermittent Duty.
Protection: Thermal Overload, Automatic Restart
Leads: 14 AWG, 14 ¾" [37 cm] Red +, 15" [38 cm] Black
Fuse: 20 Amp Recommended
Control: Shut-Off 55 PSI [3.8 Bar] ± 2 PSI [0.13 Bar]
Re-start 40 PSI [2.8 Bar] ± 2 PSI [0.13 Bar]
Maximum By-Pass 65 PSI [4.5 Bar] ± 2 PSI [0.13 Bar]

MATERIALS OF CONSTRUCTION:

Housings: Polypro
Valves/Seals: EPDM
Diaphragm: Santoprene
Hardware: Stainless Steel and Zinc Plated Steel

AGENCY APPROVALS:

Ignition Protection 8846, CE, IMCI Certified

SHIPPING INFORMATION:

Net Weight: 7.9 Pounds [3.5 Kg] ea.
Carton Qty.: 6
Carton Weight: 50 Lbs. [22.6 Kg]
Carton Size: 24"L X 18"W X 6"H [61cm x 46cm x 15cm]

REPAIR KITS

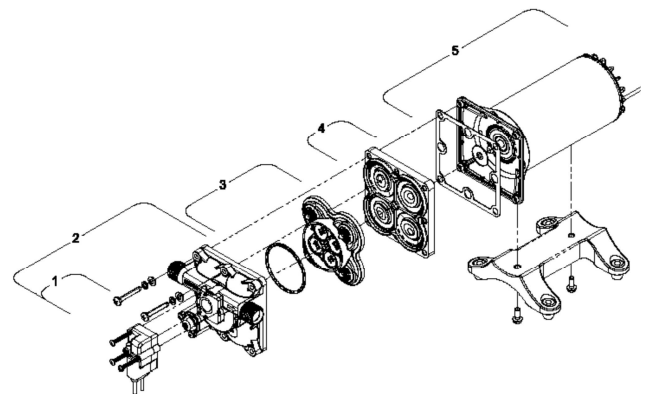

Number	Description	Part Number
1	Pressure Switch	94-801-09
1,2	Upper Assembly	94-801-10
3	Valve Assembly	94-800-01
4	Drive Assembly	94-801-02
5	Motor/Gasket	94-71-004-17
1,2,3,4	Pump Head	94-801-11
Not Shown	Check Valve	94-800-03

RELATED DOCUMENTS:

Catalog: MS-030-140
 Installation Manual: 911-1026
 Application Spec Guide: MS-020-005

TYPICAL PERFORMANCE AT 12V

PRESSURE		FLOW		CURRENT
BAR	PSI	GPM	LPM	AMPS
0	0	5.0	18.9	4.5
0.7	10	4.2	15.8	6.8
1.4	20	3.75	14.1	8.0
2.1	30	2.9	10.9	9.0
2.8	40	1.75	6.6	10.5
3.4	50	0.9	3.4	11.8
4.1	60	0.15	0.56	13.0
4.5	65	0	0	13.0

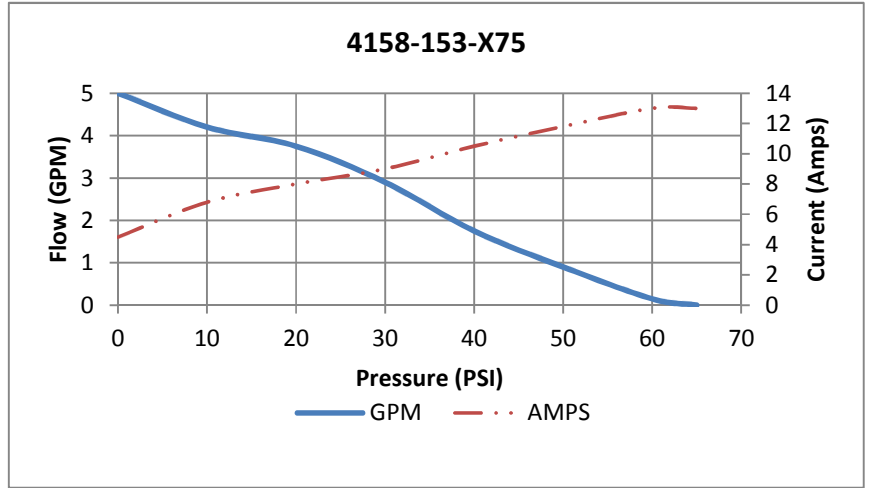

DIMENSIONS:

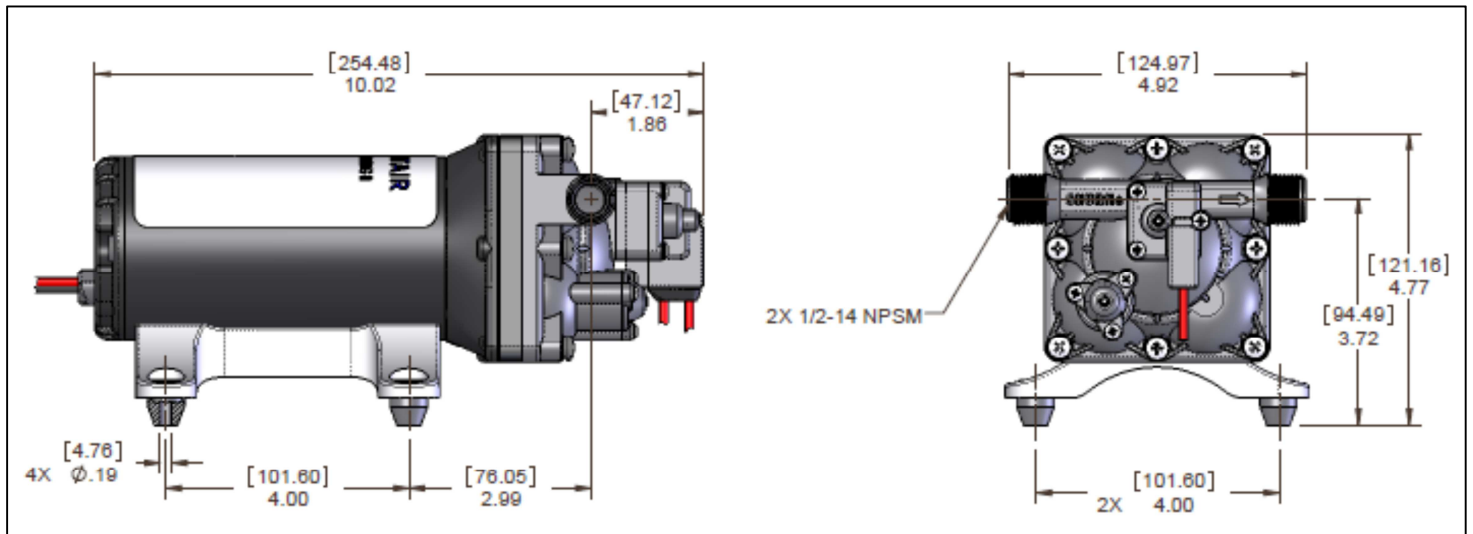

3545 Harbor Gateway South, Ste. 103, Costa Mesa, CA 92626, (800) 854-3218 www.SHURFLO.com

SHURFLO Europe, Middle East, Africa

Pentair Water Belgium bvba, Industriepark Wolfstee, Toekomstlaan 30, B-2200 Herentals, Belgium, +32-14-283500

All Pentair trademarks and logos are owned by Pentair, Inc. All other brand or product names are trademarks or registered marks of their respective owners. Because we are continuously improving our products and services, Pentair reserves the right to change specifications without prior notice.

Pentair is an equal opportunity employer.

4158-153-A75 (E75) Rev 08/12 ©2012 Pentair, Inc. All rights Reserved.